

SICCtech®

COSTRUITI PER DURARE NEL TEMPO

BOLLITORI

SERBATOI

AUTOCLAVI



2024

CATALOGO E LISTINO
CATALOG AND PRICE LIST

01 IT/EN





**BOLLITORI
SERBATOI
AUTOCLAVI**

SicCtech[®]



Bollitori, accumulatori, autoclavi e serbatoi sono suddivisi in relazione ai differenti settori di impiego e di utilizzo a cui sono destinati. Per ogni prodotto è possibile individuare tutte le principali caratteristiche tecniche, costruttive, i diversi tipi di finitura e la gamma di capacità. Un simbolo ed un colore segnalano il settore di destinazione del prodotto che prevede cinque differenti settori di produzione/utilizzo:



Storage cylinders, storage tanks, autoclaves and tanks are subdivided in relation to the area of application and the intended use. Each product is complete with all the main technical and constructional specifications, the different types of finish and range of capacities. Symbol and colours are used to identify one of five different areas of application of the product:

Energie alternative *Alternative energy*



Bollitori solari con scambiatore estraibile, fisso e per pompe di calore. Sistemi combinati per impianti sanitari e di riscaldamento e puffer.

Solar storage cylinders with removable and fixed heat exchangers, combined systems for domestic hot water and central heating systems.

Termo *Heating*



Bollitori murali, con serpentino fisso, con scambiatore estraibile. Accumulatori d'acqua calda sanitaria, bollitori per vapore e vasi d'espansione.

Storage cylinders with coils, removable heat exchangers, tank-in-tank, hot water storage tanks and expansion vessels.

Inerziale *Inertial*



Serbatoi di accumulo per acqua tecnica, all'interno di impianti di riscaldamento o condizionamento.

Storage tank for technical water in heating and cooling system.

Acqua *Water*



Sistemi monoblocco di accumulo e pressurizzazione. Serbatoi per montaliquidi e di prima raccolta in pressione.

Plug & play systems for storage and pressurization. Pressure tanks for primary water.





















Acciaio inox *Stainless steel*





















Bollitori, accumulatori e serbatoi totalmente in acciaio inox.

Storage tanks and collection tanks in stainless steel.

Indice catalogo tecnico Technical catalogue contents

	PDC HY Bollitore ibrido per pompa di calore <i>Hybrid boiler for heat pump</i>	pag. 14
	CMAX Bollitore con serpentino spiroidale fisso per POMPE DI CALORE <i>Calorifier with fixed spiral coil for HEAT PUMP</i>	pag. 16
	EVPDC Bollitore con scambiatore rimovibile per POMPA DI CALORE <i>Calorifier with removable heat exchanger for HEAT PUMP</i>	pag. 18
	SOL PDC Bollitore doppio serpentino fisso per POMPA DI CALORE <i>Calorifier with double fixed coil for HEAT PUMP</i>	pag. 20
	EV2PDC Bollitore con doppio scambiatori estraibile per POMPA DI CALORE <i>Calorifier with TWO removable exchangers for HEAT PUMP</i>	pag. 22
	CAL Bollitore solare con serpentino spiroidale fisso <i>Solar storage tank with fixed spiral coil</i>	pag. 24
	SOL Bollitore solare con doppio serpentino spiroidale fisso <i>Solar storage tank with double fixed spiral coil</i>	pag. 26
	NS1 Bollitore solare con UNO scambiatore estraibile <i>Solar storage tank with ONE removable heat exchanger</i>	pag. 28
	NS2 Bollitore solare con DUE scambiatori estraibili <i>Solar storage tank with TWO removable heat exchangers</i>	pag. 32
	NS3 Bollitore solare con TRE scambiatori estraibili <i>Solar storage tank with THREE removable heat exchangers</i>	pag. 36
	SECX Bollitore con serpentino conico fisso ALTE PRESTAZIONI <i>Storage tank with HIGH PERFORMANCE fixed conical coil</i>	pag. 40
	EVO 1 BASIC Termoaccumulo per riscaldamento e sanitario istantaneo <i>Buffer tanks for heating systems and domestic</i>	pag. 42
	EVO 2 BASIC Termoaccumulo per riscaldamento, solare termico e sanitario istantaneo <i>Buffer tank for heating, thermal solar and domestic</i>	pag. 44
	EVO 3 BASIC Termoaccumulo multienergie, solare termico e sanitario <i>Solar buffer tanks for heating systems, thermal solar and domestic</i>	pag. 46
	PS6X Puffer per impianti di riscaldamento <i>Buffer tanks for central heating systems</i>	pag. 48
	PB Puffer per impianti di riscaldamento <i>Buffer tanks for central heating systems</i>	pag. 50
	PB1R Puffer solari per impianti di riscaldamento <i>Solar buffer tanks for central heating systems</i>	pag. 52
	PB2R Puffer multienergie per impianti di riscaldamento <i>Solar buffer tanks for central heating systems</i>	pag. 54
	EVP Bollitore con scambiatore estraibile <i>Storage tank with removable heat exchanger</i>	pag. 56
	EVP LOW Bollitore con scambiatore estraibile RIBASSATO <i>Storage tank with removable heat exchanger LOWERED VERSION</i>	pag. 60
	116 Accumuli inerziali di acqua calda sanitaria <i>Domestic hot water storage tanks</i>	pag. 64

	116 LOW	<i>Accumuli ACS ribassati DHW storage tanks lowered version</i>	<i>pag. 66</i>
	316	<i>Accumuli d'acqua calda sanitaria con scambiatore a piastre Domestic hot water storage tanks with plate heat exchanger</i>	<i>pag. 68</i>
	EOP	<i>Bollitore orizzontale con scambiatore estraibile Horizontal storage tank with removable heat exchanger</i>	<i>pag. 72</i>
	EVAP	<i>Bollitore con scambiatore estraibile per vapore Storage tank with removable heat exchanger for steam</i>	<i>pag. 76</i>
	217	<i>Vasi di espansione collaudati 2014/68/UE PED Expansion vessels tested in compliance with 2014/68/UE PED</i>	<i>pag. 78</i>
	Scambiatori a Piastre Plate Heat Exchanger		<i>pag. 80</i>
	218 GP	<i>Serbatoi inerziali pensili caldo e freddo Hanging buffer tanks heating and cooling</i>	<i>pag. 82</i>
	218GHC	<i>Serbatoi inerziali caldo e freddo ISOLAMENTO MAGGIORATO Storage tanks for cooling and heating systems THICKER INSULATION</i>	<i>pag. 84</i>
	218	<i>Serbatoi inerziali per impianti di refrigerazione Storage tanks for cooling systems</i>	<i>pag. 86</i>
	320	<i>Sistemi monoblocco di accumulo e pressurizzazione Packaged storage and pressurisation system</i>	<i>pag. 90</i>
	213	<i>Serbatoi di prima raccolta in pressione Pressurised primary collection tanks</i>	<i>pag. 96</i>
	210	<i>Serbatoi per autoclave montaliquidi collaudati 2014/68/UE PED Autoclave surge tanks tested in compliance with 2014/68/UE PED</i>	<i>pag. 100</i>
	EVPXINOX	<i>Bollitori con scambiatore estraibile Storage tanks with removable heat exchanger</i>	<i>pag. 106</i>
	CALINOX	<i>Bollitori con serpentino spiroidale fisso Storage tanks with fixed spiral coil</i>	<i>pag. 108</i>
	SOLINOX	<i>Bollitori solari con doppio serpentino spiroidale fisso Solar storage tanks with double fixed spiral coil</i>	<i>pag. 110</i>
	216INOX	<i>Accumulatori d'acqua calda Hot water storage tanks</i>	<i>pag. 112</i>
	218INOX	<i>Serbatoi inerziali per impianti di refrigerazione Storage tanks for cooling systems</i>	<i>pag. 114</i>
	Ricambi e accessori Spare Parts and accessories		<i>pag. 116</i>
	Perdite di carico scambiatori estraibili Removable heat exchanger pressure drop		<i>pag. 118</i>

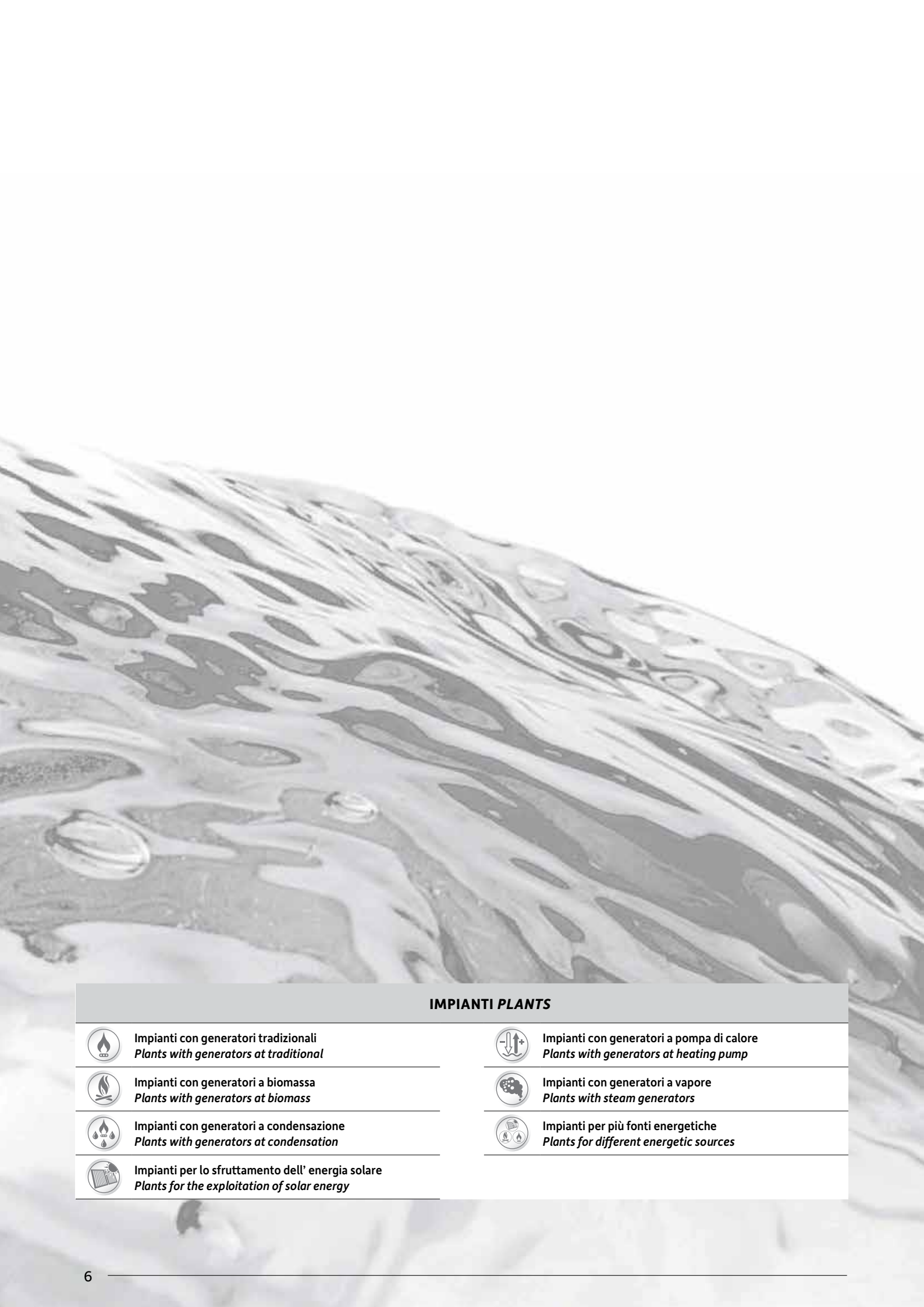

IMPIANTI PLANTS



Impianti con generatori tradizionali
Plants with generators at traditional



Impianti con generatori a biomassa
Plants with generators at biomass



Impianti con generatori a condensazione
Plants with generators at condensation



Impianti per lo sfruttamento dell' energia solare
Plants for the exploitation of solar energy



Impianti con generatori a pompa di calore
Plants with generators at heating pump



Impianti con generatori a vapore
Plants with steam generators



Impianti per più fonti energetiche
Plants for different energetic sources

Costruire serbatoi che mantengano nel tempo il valore delle loro caratteristiche To make tanks whose features keep their value over time



Con questa semplice linea guida, quotidianamente ci occupiamo di progettare, acquistare materiali, fabbricare e collaudare serbatoi per applicazioni termoidrauliche, per l'aria compressa e per il settore oil & gas.

Nei nostri 55.000 mq di stabilimento realizziamo serbatoi di serie ma anche progettati e costruiti secondo le specifiche esigenze tecniche del cliente. Tutti i nostri prodotti sono interamente realizzati in Italia, a Rovigo.

Grazie alle nostre certificazioni di processo e di prodotto, forniamo le principali aziende di impiantistica e di engineering nazionali ed estere, mentre con la logistica e la capillare rete di agenzie di rappresentanza siamo quotidianamente presenti nella distribuzione specializzata.

Nel mercato globale odierno, le imprese hanno una posizione influente nel modellare il modo in cui funziona il mondo e il futuro. Per questo motivo, le organizzazioni devono riconsiderare l'impatto a livello sociale ed etico delle loro attività e politiche. Le aziende che possono dimostrare un impegno verso la Responsabilità Sociale hanno senz'altro un vantaggio competitivo, ispirando la fiducia dei propri clienti, investitori, consumatori e comunità locali.

Questo sta guidando le nostre attività, impegnandoci giornalmente a rispettare le più rigide regole di qualità imposte dalle normative ma anche generate dal nostro senso civico.



This simple rule guides us, every day, in designing, purchasing materials, constructing and testing tanks for applications in the heating, compressed air and oil & gas sectors. In our 55,000 sq. m factory we have been making both standard tanks and models designed and built to our customers' specific technical requirements. All our receivers are entirely designed and produced in Rovigo, Italy.

Process and product certification means we supply the leading national and foreign systems and engineering companies, while our logistics and extensive network of agents and representatives ensure our products are always available through specialist distributors.

In today's global market, businesses have considerable influence in shaping how the world and the future will be. This is why organisations need to reconsider the social and ethical impact of their operations and their policies. Companies that demonstrate commitment to social responsibility certainly have a competitive advantage, inspiring loyalty in customers, investors, consumers and the local community.

These are the aspects that guide our business, committed every day to ensuring the strictest quality requirements set by standards and dictated by our sense of civic responsibility.



Qualità e ambiente: una scelta ecologica Quality & the environment: an ecological choice



POLITICA DELLA QUALITÀ - UNI EN ISO 9001:2015

L'obiettivo principale della politica della qualità è costituito dalla soddisfazione dei clienti e dal continuo miglioramento della qualità e dell'affidabilità del prodotto in un contesto di adeguata redditività.

La nostra Azienda intende perseguire gli obiettivi della Qualità e del suo miglioramento. Per questo motivo la Qualità deve essere perseguita in ogni fase e momento dell'attività. Particolare cura deve essere posta nell'applicazione dei metodi della Qualità, nella progettazione, nella realizzazione delle tecnologie del prodotto aziendale, nel collaudo e nella consegna ed assistenza al cliente dei prodotti finiti. La consegna deve essere corredata di manuali d'uso e installazione nonché di tutti gli altri documenti tecnici necessari.

La nostra azienda intende raggiungere la Qualità attraverso la consapevolezza diffusa in tutti i dipendenti dei seguenti principi base:

- lavoro privo di errori (esecuzione corretta del lavoro fin dalla prima volta);
- soddisfazione del cliente;
- gestione della prevenzione nel complesso delle attività aziendali;
- rispetto delle leggi cogenti.

Il raggiungimento di quanto sopra descritto diventa il punto di partenza per un miglioramento continuo che deve coinvolgere ogni tipologia di lavoro in qualunque situazione operativa.

Per ottenere tali risultati, in particolare, risulta essenziale:

- una costante sensibilizzazione alle esigenze del cliente, espresse o implicite;
- un ininterrotto processo di addestramento e formazione del personale;
- una adeguata sensibilizzazione, coinvolgimento e responsabilizzazione delle singole persone attraverso momenti di incontro e condivisione, per instaurare una visione di tipo globale che favorisca azioni organizzative efficaci;
- un atteggiamento personale a tutti i livelli concretamente orientato alla soddisfazione delle aspettative dei clienti;
- un continuo miglioramento dei sistemi di pianificazione e di controllo degli aspetti produttivi e finanziari dell'impresa;
- il raggiungimento e mantenimento della Certificazione secondo le norme UNI EN ISO 9001: 2015.

Ogni persona deve pertanto sentirsi responsabile della qualità del proprio operato ed ogni azione ed atteggiamento devono essere considerati e valutati in funzione di tale responsabilità.

Viene data ampia informazione e diffusione all'interno dell'azienda della politica della qualità espressa dalla Direzione.



QUALITY POLICY - UNI EN ISO 9001:2015

The main objectives of our quality policy are customer satisfaction and continual improvement in product quality and reliability, within a context of appropriate profitability. Our company is committed to pursuing these quality and improvement objectives. For this reason, quality is pursued in every step and every stage of our business. Special care is paid to applying quality methods in design and development of company product technology, testing, delivery and service to the users of the finished products. Products are delivered with user and installation manuals and all other necessary technical documents.

Our company aims to achieve quality by instilling awareness of the following essential principles in all employees:

- *error free work (all operations completed right first time);*
- *customer satisfaction;*
- *management of prevention within the company's operations;*
- *compliance with applicable laws.*

Achieving these aims is the starting point for continual improvement, which must involve all work done in every operational situation.

Indeed, the following are fundamental in achieving these results:

- *ongoing staff training and education;*
- *constant awareness of customer needs, both explicit and implicit;*
- *awareness, involvement and assumption of responsibility by individuals through meetings and exchanges, so as to establish a global vision that encourages effective organisational actions;*
- *personal attitude at all levels focused on satisfying customer expectations;*
- *continual improvement in the company's production and financial planning and control systems;*
- *achievement and maintenance of certification according to UNI EN ISO 9001:2015.*

Each person must therefore be responsible for the quality of their own work, and each action and attitude must be considered and assessed according to such responsibilities. Considerable information is provided throughout the company on the quality policy expressed by Management.



POLITICA AMBIENTALE - UNI EN ISO 14001:2015

La società riconosce come prioritario operare in modo che le proprie attività e servizi arrechino il minor danno all'ambiente, facendo propri i principi della tutela ambientale e perseguendo il miglioramento continuo del proprio sistema di gestione ambientale. Per questo la Direzione esprime il proprio impegno per promuovere la corretta gestione di tutte le attività direttamente svolte o controllate, ponendo una particolare attenzione verso quelle che presentano un maggiore impatto ambientale.

Le linee strategiche dalle quali emergeranno di volta in volta le scelte di intervento sono:

- il rispetto di tutta la legislazione, nazionale regionale e provinciale, in materia di tutela ambientale, nonché di tutte le prescrizioni sottoscritte dall'azienda;
- la prevenzione dall'inquinamento attraverso l'adozione di attività di monitoraggio e controllo;
- il continuo miglioramento delle proprie prestazioni ambientali attraverso la pianificazione di specifici obiettivi e traguardi ambientali; tale impegno deve essere diffuso a tutti i livelli dell'organizzazione;
- la formazione di tutto il personale operante all'interno della struttura sulle tematiche di tutela e valorizzazione dell'ambiente e sull'effetto che la propria attività può avere sull'ambiente;
- l'adozione di tecniche e prodotti alternativi da utilizzare nei processi a maggior rischio ambientale per ridurre gli impatti sull'ambiente;
- il contenimento dei consumi energetici;
- la riduzione delle cause di inquinamento ambientale, in particolare per quanto riguarda lo scarico di acque reflue e le emissioni in atmosfera;
- il contenimento della produzione di rifiuti, in tutti i reparti produttivi.

Per il raggiungimento di tali obiettivi l'azienda ha analizzato il quadro completo delle proprie attività e degli aspetti ambientali su cui queste possono influire, prendendo a riferimento tutte le leggi e regolamenti vigenti. Inoltre l'azienda si è posta obiettivi di miglioramento distinti per funzione e ha definito modalità, tempi, mezzi e risorse per il raggiungimento di obiettivi e traguardi. **SICCTECH** si pone l'obiettivo di inserire la fase di verifica degli aspetti ambientali in ogni azione e decisione inerente la progettazione di nuovi processi e la modifica di quelli esistenti, scelta di macchine, attrezzature e prodotti. In ottica di miglioramento **SICCTECH** si impegna a tenere costantemente sotto controllo i vari parametri ambientali al fine di intervenire prontamente nel caso si verificassero situazioni che potrebbero portare ad impatti ambientali significativi.



ENVIRONMENTAL POLICY - UNI EN ISO 14001:2015

The company recognises the importance of working in such a way that its actions and services create the minimum possible damage to the environment, adopting the principles of environmental protection and pursuing continual improvement of its environmental management system. Consequently, the Management expresses its commitment to promoting correct management of all activities, both carried out directly and controlled, with special emphasis on those that have greater environmental impact.

The strategic guidelines that form the basis for the operational decisions made are:

- *compliance with all legislation on environmental protection, at a national, regional and provincial level, as well as all provisions the company commits to;*
- *prevention of pollution through monitoring and control processes;*
- *continual improvement in its environmental performance through the planning of specific environmental objectives and targets; this commitment must be encouraged throughout all levels of the organisation;*
- *training of all personnel working within the organisation on the issues of protecting and valuing the environment and the effects that their activities may have on the environment;*
- *use of alternative techniques and products within the processes with greater environmental risk, so as to reduce environmental impact;*
- *reduction in energy consumption;*
- *reduction in the causes of environmental pollution, specifically as regards the discharge of waste water and emissions into the atmosphere;*
- *reduction in waste production in all production departments.*

To achieve these objectives, the company has analysed its operations as a whole and the environmental aspects that these may affect, with a reference to all laws and regulations in force.

*Moreover, the company has set distinct improvement objectives for each department, and has defined the methods, times, means and resources needed to reach these objectives and targets. **SICCTECH** aims to introduce environmental verification into every action and decision regarding the design of new processes and the modification of existing ones, and the choice of machinery, equipment and products.*

*For the purpose of improvement, **SICCTECH** is committed to constantly monitoring the various environmental parameters so as to take prompt action should any situations occur that may have a significant environmental impact.*



COIBENTAZIONI

La coibentazione dei serbatoi viene eseguita con materiali ad alto potere isolante ottenuti senza l'uso di CFC o HCFC (in accordo con le Direttive Europee 2002/95/CE e 2003/11/CE). Il materiale ha una struttura di fitte celle (decine per cm) nelle quali è contenuto un gas a bassa conducibilità termica. Gli isolanti permettono una ridotta dispersione di calore, migliori rendimenti energetici e un'ottimale gestione dell'impianto. Le coibentazioni utilizzate nei nostri serbatoi per acqua calda, si dividono in tre tipologie:

- Poliuretano rigido: reazione al fuoco B3 (DIN 4102);
- Polistirolo rigido: **reazione al fuoco Euroklasse E (EN 13163)**;
- Fibra di poliestere **ECOFIRE**: reazione al fuoco CLASSE 1 (UNI 9177); 100% RICICLABILE;
- Poliuretano morbido;
- **Tutti i serbatoi coibentati per acqua calda rispettano i requisiti richiesti dalle direttive 2009/125/CE e 2010/30UE sull'efficienza energetica.**



INSULATION

The tanks are lagged using materials with high insulating capacity, without using CFCs or HCFCs (in accordance with European Directives 2002/95/EC and 2003/11/EC). The material has a dense cell structure (dozens per cm) containing gas with low thermal conductivity. The insulation ensures reduced heat loss, better energy efficiency and optimum system management. Three types of insulation are used on our hot water tanks:

- Rigid polyurethane: reaction to fire class B3 (DIN 4102);
- Rigid polystyrene: reaction to fire class Euroklasse E (EN 13163);
- Polyester fibre **ECOFIRE**: reaction to fire CLASS 1 (UNI 9177); 100% RECYCABLE;
- Soft polyurethane.
- **All the insulated tanks for hot water, comply with the directive 2009/125/CE and 2010/30UE about energy efficiency.**



TRATTAMENTO ANTICORROSIVO VITROFLEX®

Il VITROFLEX è un'ottima alternativa alla vetrificazione. Dalle prove eseguite presso un laboratorio esterno è risultato che le polveri di VITROFLEX, dopo 1650 ore nella lampada di Amoco, non hanno mostrato alcun effetto di blistering. Dalla nostra esperienza risulta che 100 ore nella lampada di Amoco sono da paragonare ad un anno di funzionamento. Questo spiega perché il trattamento VITROFLEX dà sicurezza e garanzia.

Il trattamento è idoneo al contatto con acqua alimentare in base al regolamento europeo e il processo di rivestimento si riassume nelle seguenti fasi:

- Sabbiatura interna del serbatoio dell'acqua sanitaria e fosfatazione;
- Lavaggio con acque demineralizzate e conseguente asciugatura;
- Applicazione della resina epossidica termoindurente mediante verniciatura a spruzzo;
- Cottura in forno a ~ 240°C.



VITROFLEX®



VITROFLEX® CORROSION-PROOFING

VITROFLEX is an alternative to vitrification. Tests carried out by an external laboratory have highlighted that VITROFLEX powder, after 1650 hours under an Amoco lamp, showed no effects of blistering. Our experience shows that 100 hours under an Amoco lamp is comparable to one year's operation. This explains why VITROFLEX treatment offers guaranteed safety.

The treatment is suitable for contact with drinking water according to European regulations.

The coating process involves the following stages:

- Sandblasting and phosphating inside the domestic hot water tank;
- Washing with demineralised water and then drying;
- Application of thermosetting epoxy resin by spray painting;
- Baking in a furnace at ~ 240°C.



TRATTAMENTO DI ZINCATURA A BAGNO CALDO

La zincatura è un sistema di protezione dell'acciaio dal fenomeno della corrosione.

Il rivestimento di zinco che si ottiene dal trattamento è perfettamente aderente all'intera superficie del serbatoio e copre anche angoli scomodi e buchi molto stretti, offrendo all'acciaio una protezione catodica completa.

Nel tempo la dissoluzione dello zinco avviene lentamente ottenendo il vantaggio di una vita utile del prodotto allungata.

L'acciaio verrà attaccato solamente quando la copertura sarà completamente consumata.

Il processo di zincatura a caldo consiste nell'immersione del serbatoio in un bagno di zinco fuso, tenuto mediamente alla temperatura di 455 gradi; in questa fase lo zinco, oltre a ricoprire l'acciaio, entra anche in lega con lo strato superficiale conferendo resistenza meccanica e il giusto grip al materiale trattato.



HOT DIP GALVANISATION

Galvanisation is a system for protecting steel against corrosion.

The zinc coating created by the treatment adheres perfectly to the entire surface of the tank, also covering hard-to-access corners and narrow openings, providing complete cathodic protection on steel.

The zinc dissolves slowly over time, thus extending useful product life.

The steel is attacked only when the coating is completely consumed.

The hot galvanisation process involves dipping the tank in a bath of molten zinc, at an average temperature of 455 degrees; in this stage the zinc, as well as covering the steel, also alloys with the surface layer, providing the treated material with mechanical strength and good grip.



TRATTAMENTO DI VETRIFICAZIONE

Il trattamento con smalto porcellanato, detto anche "VETRIFICAZIONE", si ottiene con l'applicazione di uno o due strati (a seconda dei casi) di smalto con caratteristiche di resistenza all'acqua ed al vapore, che conferisce al prodotto trattato un'elevata protezione della salute e dell'ambiente.

I prodotti non trattati sono soggetti a corrosione a causa della presenza di ossigeno e di sali minerali disciolti nell'acqua.

La completa affidabilità di questo tipo di trattamento deriva dalla sua composizione inorganica e dal legame creato tra lo smalto stesso e la superficie metallica.

Dopo la cottura in forno a ~850°C secondo metodo Bayer e norma DIN 4753.3, lo smalto non assorbe acqua e non conduce ioni, quindi la vetrificazione protegge la struttura del prodotto al 99,9%.

Il rimanente 0,1% (dovuto ad eventuali punti scoperti) viene eliminato inserendo, all'interno del prodotto, sistemi anticorrosivi di protezione, come anodi sacrificali di magnesio o anodi con sistema elettronico permanente.



VITRIFICATION

Treatment with vitreous enamel, also called "VITRIFICATION", involves applying one or two layers (depending on the situation) of enamel that is both water and steam resistant, giving the treated product a high level of protection in relation to health and the environment.

Untreated products can be attacked by corrosion due to oxygen and mineral salts dissolved in the water. The complete reliability of this type of treatment is due to its inorganic composition and the link created between the enamel and the metal surface.

After baking in a furnace at around 850°C according to the Bayer method and standard DIN 4753.3, the enamel does not absorb water and does not conduct ions, consequently vitrification offers 99.9% protection to the structure of the product.

The remaining 0.1% (due to possible uncoated areas) is provided by fitting the product with corrosion protection systems, such as magnesium sacrificial anodes or anodes with permanent electronic systems.



ANODO DI MAGNESIO E TESTER DI CONTROLLO

Alcuni prodotti sono protetti internamente contro i danni della corrosione da un sistema completamente attivo mediante anodi di magnesio. Per proteggere la struttura in acciaio l'anodo sacrificale si consuma. E' per tale motivo che lo stato di usura deve essere verificato almeno ogni sei mesi. Il tester permette di realizzare questo controllo senza la necessità di smontare l'anodo: con una semplice pressione del tasto presente sul tester, sul quadro si potrà leggere se è necessario sostituire l'anodo.

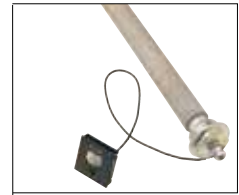

MAGNESIUM ANODE AND TESTER

Some products are protected internally against damage due to corrosion by a completely active system using magnesium anodes. The sacrificial anode is consumed so as to protect the steel structure. This is why its condition needs to be checked at least every six months. The tester performs this check without needing to remove the anode: by simply pressing the button on the tester, the panel will show whether the anode needs to be replaced.



PROTEZIONE CATHODICA CON ANODO A CORRENTE IMPRESSA A.C.I.

Per evitare continui controlli e sostituzioni degli anodi di magnesio, alcuni prodotti possono essere correati di un sistema di protezione permanente dell'acciaio con anodo a corrente impressa. Tale sistema garantisce una protezione elettrica costante nel tempo mediante l'utilizzo di una bacchetta di titanio e di un potenziostato: lo strumento confronta in tempo reale il potenziale all'interno del serbatoio con il potenziale teorico e, di conseguenza, emette una corrente necessaria a proteggere l'intero bollitore. Il sistema non richiede alcuna manutenzione, è assolutamente privo di usura ed agisce sempre in modo efficace. Inoltre il nostro sistema ACI ha un consumo di corrente inferiore ai 10 kWh/anno.

Può essere montato anche su bollitori già installati e funzionanti.



IMPRESSED CURRENT CATHODIC PROTECTION (ICCP)

To avoid the need to continuously monitor and replace magnesium anodes, some products can be fitted with a system for permanent protection of the steel by impressed current anode.

This system guarantees continuous electrical protection over time using a titanium rod and a potentiostat: the instrument instantly compares the potential inside the tank against the theoretical potential and consequently applies the current needed to protect the entire storage cylinder. The system does not require maintenance, is not subject to any wear and is always effective. Moreover, our ICCP system has an annual power consumption of less than 10 kWh.

This system can also be retro-fitted on storage cylinders that are installed and operating.



La corrosione è un fenomeno naturale che porta al deterioramento (più o meno veloce) del metallo, dovuto alla sua reazione con l'ambiente che lo circonda.

Nei serbatoi, la superficie più sensibile alla corrosione è la parte a contatto con l'acqua, poiché, essendo ricca di ossigeno, si alimentano all'interno fenomeni elettrochimici che possono usurare il materiale stesso. In questo ambiente si sviluppano correnti galvaniche, che si sviluppano quando due metalli diversi sono messi a contatto in una soluzione elettrolitica (basti pensare ad un serbatoio in acciaio al carbonio con scambiatore in acciaio inox), oppure fenomeni di corrosione generalizzata, che va a scalfire le aree catodiche o anodiche, in base alla nobiltà del materiale, oppure corrosioni da ossigeno, che si sviluppa dalla reazione dell'ossigeno a contatto con il metallo. L'efficacia del fenomeno dipende dai valori dell'acqua (pH, durezza, etc.) e dalla tipologia impiantistica corredata al serbatoio. Per prevenire tali fenomeni, la Sicc Tech realizza il proprio trattamento Vitroflex e inserisce, all'interno dei propri serbatoi, anodi protettivi.



Corrosion is a natural phenomenon that leads to the deterioration (more or less fast) of the metal, due to its reaction with the environment that surrounds it.

In tanks, the surface most sensitive to corrosion is the part in contact with water, since, being rich in oxygen, electrochemical phenomena are fed inside which can wear down the material itself. In this environment, galvanic currents develop, which develop when two different metals are put in contact in an electrolytic solution (just think of a carbon steel tank with a stainless steel exchanger), or generalized corrosion phenomena, which will scratch cathodic or anodic areas, based on the nobility of the material, or corrosion by oxygen, which develops from the reaction of oxygen in contact with the metal. The effectiveness of the phenomenon depends on the water values (pH, hardness, etc.) and on the type of system supplied with the tank. To prevent these phenomena, Sicc Tech carries out its Vitroflex treatment and inserts protective anodes inside its tanks.



SCAMBIATORI A PIASTRE

Gli scambiatori a piastre ispezionabili **SICCTECH** sono costituiti da un pacco di piastre stampate in acciaio inossidabile di altissima qualità e da guarnizioni NBR.

La particolare conformazione del canale creato da due piastre consente di raggiungere alti coefficienti di scambio e un'elevata turbolenza che aiuta a ridurre al minimo l'accumulo di residui.

Gli scambiatori sono a doppia parete e composti da piastre accoppiate, in modo da formare una doppia parete di sicurezza. Quindi in caso di fori o tagli alla prima piastra della coppia, il fluido fuoriesce lateralmente evitando la contaminazione del secondo circuito.

I nostri scambiatori a piastre, installati in accoppiamento ai nostri accumuli, si distinguono per alto rendimento termico, dimensioni compatte, ampia versatilità, compatibilità con numerosi fluidi e peso ridotto rispetto agli scambiatori a fascio tubiero. Inoltre hanno un buon effetto autopulente grazie all'alta turbolenza.

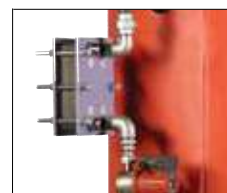

PLATE HEAT EXCHANGERS

SICCTECH openable plate heat exchangers are made from a series of very high quality pressed stainless steel plates and NBR gaskets.

The specific layout of the channel created between two plates ensures high heat exchange coefficients and a high degree of turbulence, helping minimise the amount of residues accumulated. These are double-wall heat exchangers made from pairs of plates, with the double wall ensuring a high degree of safety. Indeed, if the first plate in the pair is punctured or cut, the fluid comes out from the side, avoiding contamination in the second circuit.

The plate heat exchangers fitted in our storage tanks stand out for their high thermal efficiency, compact dimensions, versatility, compatibility with numerous fluids and light weight compared to tube bundle heat exchangers.

The high turbulence created also means they are self-cleaning.



SCAMBIATORI A FASCIO TUBIERO E GUARNIZIONI

Gli scambiatori a fascio tubiero montati nei prodotti **SICCTECH** sono costruiti in modo da sfruttare al massimo gli alti coefficienti di scambio e, al contempo, assicurare un lungo funzionamento senza interruzioni. Gli scambiatori di calore di tipo estraibile sono costituiti da un fascio di tubi in acciaio inox, in rame o acciaio al carbonio zincato a caldo, piegati ad "U" e mandrinati su piastra di elevato spessore. Sono progettati per pressioni fino a 12 bar e per temperature di esercizio che variano per tipologia di prodotto (scambiatore per acqua o vapore). Sono montati con idonee guarnizioni ed isolati elettricamente dal bollitore mediante isolatori in PVC. Le guarnizioni utilizzate per scambiatori per acqua sono in elastomero impermeabile EPDM, un materiale elastico dalle caratteristiche eccellenti di resistenza agli agenti atmosferici, ottime caratteristiche di resistenza termica e ai raggi UV, resistenza agli sbalzi di temperatura (-50 / +125°C) ed eccellenti proprietà meccaniche (carico di rottura, allungamento, resistenza alla lacerazione). Le guarnizioni utilizzate per gli scambiatori per vapore sono realizzate in grafite armata con rete in acciaio inox. Questa particolare costruzione le rende particolarmente idonee a resistere ad elevate temperature e sollecitazioni meccaniche.



TUBE BUNDLE HEAT EXCHANGERS AND GASKETS

*The tube bundle heat exchangers fitted on **SICCTECH** products are made to gain the maximum possible benefit from the high heat exchange coefficients and, at the same time, ensure extended interruption-free operation. The heat exchangers used are removable U-shaped tube bundles made from stainless steel, copper or hot galvanised carbon steel, expanded onto thick metal plates. They are designed to operate at pressures up to 12 bars and temperatures that vary according to the type of product (heat exchangers for water or steam). They are fitted with suitable gaskets and electrically insulated from the storage cylinders by PVC insulators. The gaskets used on water heat exchangers are made from impermeable EPDM elastomer, an elastic material with outstanding resistance to the weather, heat and UV radiation, a very wide range of operating temperatures (-50 / +125°C) and excellent mechanical properties (breaking strength, elongation, tear strength). The gaskets used on steam heat exchangers are made from graphite reinforced with stainless steel mesh. This specific constructional solution makes them especially suitable for resisting high temperatures and mechanical stress.*



PDC HY

Bollitore ibrido per pompa di calore
Hybrid boiler for heat pump



I prodotti della serie PDC HY sono bollitori ibridi per la produzione e l'accumulo di acqua calda sanitaria e di riscaldamento. Lo sviluppo dello scambiatore, assicura una elevata resa termica. Il Puffer inferiore funge da volano per l'acqua tecnica di riscaldamento. Il sistema ibrido è ideale per l'alimentazione con pompa di calore, permettendo così di ridurre gli spazi.



The PDC HY series products are hybrid boilers for the production and storage of domestic hot water and heating. The development of the heat exchanger ensures a high thermal output. The lower Puffer acts as a flywheel for the heating circuit. The hybrid system is ideal for powering with a heat pump, thus allowing to reduce space.

Tutti i serbatoi coibentati rispettano i requisiti richiesti dalle direttive 2009/125/CE e 2010/30/UE sull'efficienza energetica.
All the insulated tanks, comply with the directive 2009/125/CE and 2010/30UE about energy efficiency.

CARATTERISTICHE TECNICHE TECHNICAL FEATURES

Costruzione accumulo <i>Storage tank construction</i>	Acciaio al carbonio di elevata qualità <i>High quality carbon steel</i>
Trattamento interno <i>Inside treatment</i>	Vetrificazione, idoneo per acqua uso alimentare secondo le direttive CE, D.M. 174 <i>Vitrification suitable for drinking water in accordance with EC directives</i>
Trattamento interno Puffer <i>Puffer Internal Treatment</i>	Trattamento interno grezzo <i>Internal treatment raw</i>
Isolamento <i>Insulated</i>	Poliuretano rigido iniettato, spessore 50 mm <i>Injected rigid polyurethane, 50 mm thick</i>
Rivestimento esterno <i>Outside covering</i>	PVC accoppiato <i>Laminated PVC</i>
Accumulo <i>Storage tank</i>	Pmax 10 bar - Tmax 95°C
Scambiatore <i>Heat exchanger</i>	Pmax 12 bar - Tmax 110°C
Puffer	Pmax 3 bar - Tmax 95°C
Accessori di serie <i>Standard accessories</i>	Anodo di magnesio <i>Magnesium anode</i>
Garanzia <i>Warranty</i>	5 anni <i>5 years</i>

PDC HY

VETRIFICAZIONE VITRIFICATION

Isolamento rigido spessore 50 mm

Rigid insulation 50 mm thick

	Codice <i>Code</i>	€	Classe Energetica ErP
300	PDCHY0300C		C

Listino prezzi accessori e ricambi a pagina 116

Accessories and spare parts price list available at page 116

Esempio di impianto Example of a system

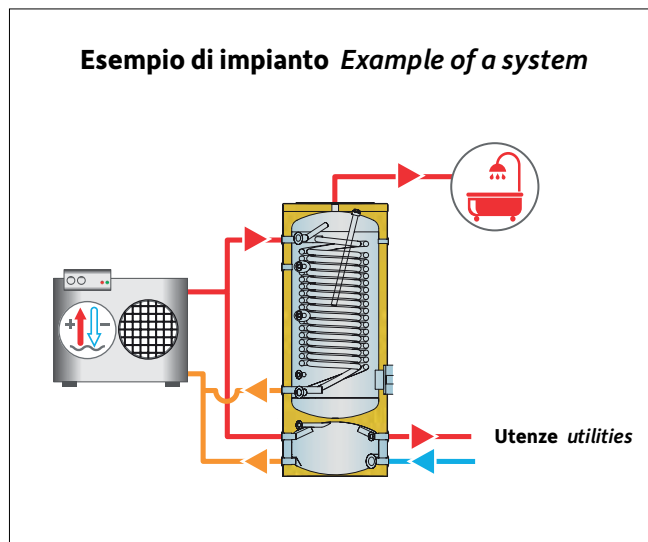



Disegno tecnico Technical drawing

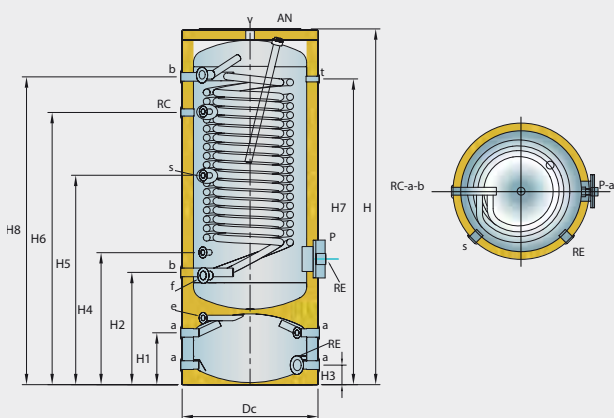

v	Ausiliario Auxiliary fitting
f	Ingresso acqua sanitaria Domestic water circuit inlet
g	Uscita acqua calda sanitaria Domestic hot water circuit outlet
s-t	Sonda Probe
b	in/out scambiatore in/out exchanger
RC	Ricircolo Recirculation
e	Ausiliario Auxiliary
AN	Anodo Anode
P	Flangia di ispezione Inspection opening
RE	Resistenza Resistance
a	in/out puffer in/out buffer

lt	CONNESSIONI CONNECTIONS									
	a-b	v	e	f	s	t	RC	AN	RE	P
250/60	G1"-F	G1"-F	G1/2"-F	G1"-F	G1/2"-F	G1/2"-F	G3/4"-F	G1"1/4"-F	G1"1/2"-F	ø110/180

lt	DIMENSIONALE SIZES (mm)										Peso Weight (Kg)
	Dc	H	H1	H2	H3	H4	H5	H6	H7	H8	
250/60	650	1720	250	530	100	630	1000	1340	1470	1495	220

PRESTAZIONI PERFORMANCE					
lt	m ²	⁽¹⁾ KW	l/h	⁽²⁾ min	⁽³⁾ l/h
250/60	4,3	70	3268	30	1400

(1) Potenza termica dello scambiatore calcolata ipotizzando una temperatura di ingresso/uscita 60/50°C, temperatura di accumulo 50°C e di ingresso sanitario di 10°C;

(2) Quantità di acqua calda sanitaria disponibile alla temperatura di utilizzo di 45°C in continuo;

(3) Tempo necessario per innalzare la temperatura dell'acqua in ingresso sanitario, 10°C, alla temperatura di accumulo pari a 50°C.

(1) Heat exchanger output calculated assuming a primary circuit inlet/outlet temperature of 60/50°C, a storage temperature of 50°C and a DHW inlet temperature of 10°C;

(2) Quantity of domestic hot water available at a delivery temperature of 45°C, continuously;

(3) Time needed to increase the domestic water inlet temperature, 10°C, to the storage temperature of 50°C.

lt	Capacità accumulo (lt.) Storage tank capacity (lt.)
l/h	Portata primario (l/h) Primary flow-rate (l/h)

m ²	Superficie di scambio (m ²) Heat exchanger surface (m ²)
l/h	Portata ACS (l/h) DHW flow-rate (l/h)

KW	Potenza di scambio (Kw) Heat exchanger power (Kw)
min	Tempo di messa a regime (min.) Time to reach temperature (min.)

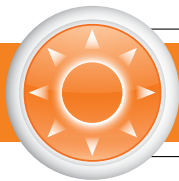

I prodotti della serie CMAX sono bollitori per la produzione e l'accumulo di acqua calda sanitaria. Le spire inferiori dello scambiatore arrivano fino alla parte più bassa del bollitore riscaldando così una maggiore quantità di acqua. Lo scambiatore è caratterizzato da una superficie di scambio elevata per ottenere le massime prestazioni con calore fornito da una pompa di calore.



The CMAX series products are storage tanks for the production and storage of domestic hot water. The bottom coil of the heat exchanger runs down to the bottom of the storage tank, thus heating a higher volume of water. The heat exchanger is featured a high heat exchange to ensure maximum performance with heat provided by a heat pump.

Tutti i serbatoi coibentati rispettano i requisiti richiesti dalle direttive 2009/125/CE e 2010/30/UE sull'efficienza energetica.

All the insulated tanks, comply with the directive 2009/125/CE and 2010/30UE about energy efficiency.

CARATTERISTICHE TECNICHE TECHNICAL FEATURES

Costruzione accumulo <i>Storage tank construction</i>	Acciaio al carbonio di elevata qualità <i>High quality carbon steel</i>
Trattamento interno <i>Inside treatment</i>	Vetrificazione, idoneo per acqua uso alimentare secondo le direttive CE, D.M. 174 <i>Vitrification suitable for drinking water in accordance with EC directives</i>
Isolamento <i>Insulated</i>	Poliuretano rigido iniettato, spessore 50 mm <i>Injected rigid polyurethane, 50 mm thick</i>
Rivestimento esterno <i>Outside covering</i>	PVC accoppiato <i>Laminated PVC</i>
Accumulo <i>Storage tank</i>	Pmax 10 bar - Tmax 95°C
Scambiatore <i>Heat exchanger</i>	Pmax 12 bar - Tmax 110°C
Accessori di serie <i>Standard accessories</i>	Anodo di magnesio <i>Magnesium anode</i>
Garanzia <i>Warranty</i>	5 anni <i>5 years</i>

CMAX

VETRIFICAZIONE VITRIFICATION

Isolamento rigido spessore 50 mm

Rigid insulation 50 mm thick

	Codice <i>Code</i>	€	Classe Energetica ErP
200	CMAX0200IN		C
300	CMAX0300IN		C
500	CMAX0500IN		C

Listino prezzi accessori e ricambi a pagina 116

Accessories and spare parts price list available at page 116

Esempio di impianto Example of a system

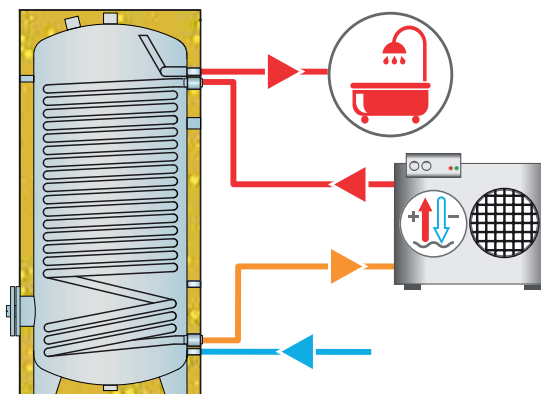

Prodotti conformi alla direttiva 2014/68/UE PED (Art.4 Par.3)

Products complying with the directive 2014/68/UE PED (Art.4 Par.3)



Disegno tecnico Technical drawing

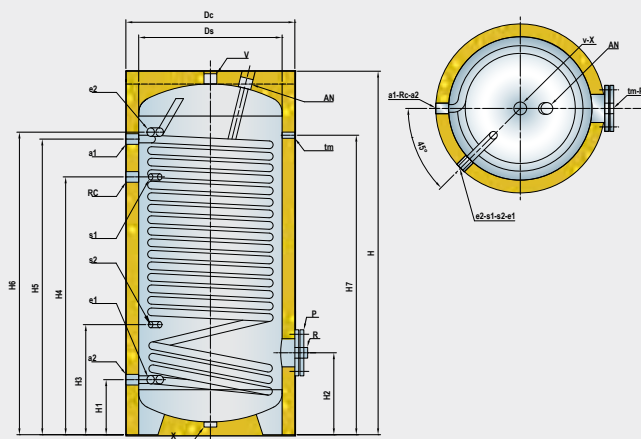

v	Ausiliario Auxiliary fitting
e1	Ingresso acqua sanitaria Domestic water circuit inlet
e2	Uscita acqua calda sanitaria Domestic hot water circuit outlet
s1-s2	Sonda Probe
a1	Ingresso circuito solare Solar circuit inlet
a2	Uscita circuito solare Solar circuit outlet
RC	Ricircolo Recirculation
R	Resistenza Resistance
AN	Anodo Anode
P	Flangia di ispezione Inspection opening
X	Scarico Drain

lt	CONNESSIONI CONNECTIONS											
	e1	e2	a1	a2	v	AN	RC	tm	s1-s2	X	P	R
200	G1"-F	G1"-F	G1"-F	G1"-F	G1"-F	G1"1/4-F	G3/4"-F	G1/2"-F	G1/2"-F	G1"-F	ø110/180	G1"1/2
300	G1"-F	G1"-F	G1"-F	G1"-F	G1"-F	G1"1/4-F	G3/4"-F	G1/2"-F	G1/2"-F	G1"-F	ø110/180	G1"1/2
500	G1"1/2-F	G1"1/2-F	G1"-F	G1"-F	G1"-F	G1"1/4-F	G1"-F	G1/2"-F	G1/2"-F	G1"-F	ø110/180	G1"1/2

lt	DIMENSIONALE SIZES (mm)										Peso Weight (Kg)
	Ds	Dc	H	H1	H2	H3	H4	H5	H6	H7	
200	460	560	1340	182	310	410	950	1122	1160	1140	95
300	510	610	1700	230	300	370	1225	1475	1475	1200	130
500	650	750	1900	250	345	430	1390	1625	1640	1370	195

PRESTAZIONI PERFORMANCE									
lt	m ²	Cond. 1				Cond. 2			
		KW	l/h	l/h	min ⁽²⁾	KW	l/h	l/h	min ⁽²⁾
200	1,9	30	5110	620	22	33	2800	675	20
300	3,3	49,5	8514	1021	30	54,5	4687	1124	27
500	4,6	69,0	11868	1424	37	76,0	6536	1568	32

(1) Potenza termica dello scambiatore calcolata ipotizzando una temperatura di ingresso/uscita 55/50 °C in cond. 1 e 60/50°C in cond. 2, temperatura di accumulo 50°C e di ingresso sanitario di 10°C;

(2) Quantità di acqua calda sanitaria disponibile alla temperatura di utilizzo di 45°C in continuo;

(3) Tempo necessario per innalzare la temperatura dell'acqua in ingresso sanitario, 10°C, alla temperatura di accumulo pari a 50°C.

(1) Heat exchanger output calculated assuming a primary circuit inlet/outlet temperature of 55/50°C at cond. 1 and 60/50°C at cond. 2, a storage temperature of 50°C and a DHW inlet temperature of 10°C;

(2) Quantity of domestic hot water available at a delivery temperature of 45°C, continuously;

(3) Time needed to increase the domestic water inlet temperature, 10°C, to the storage temperature of 50°C.

lt	Capacità accumulo (lt.) Storage tank capacity (lt.)
l/h	Portata primario (l/h) Primary flow-rate (l/h)

m ²	Superficie di scambio (m ²) Heat exchanger surface (m ²)
l/h	Portata ACS (l/h) DHW flow-rate (l/h)

KW	Potenza di scambio (Kw) Heat exchanger power (Kw)
min	Tempo di messa a regime (min.) Time to reach temperature (min.)



EVPDC

Bollitore con scambiatore rimovibile per POMPA DI CALORE
Calorifier with removable heat exchanger for HEAT PUMP



I prodotti della serie EVPDC sono bollitori per la produzione e l'accumulo di acqua calda sanitaria. Gli scambiatori di calore sono a fascio tubiero estraibile, con tubi in acciaio inossidabile mandrinati su piastra in acciaio trattata VITROFLEX. Una grande potenzialità di scambio unita a perdite di carico trascurabili li rendono il compromesso ideale fra potenza installata e volume d'acqua calda accumulato, sono ideali per impianti sanitari ove il prelievo di acqua calda raggiunge punte di richiesta elevate (centri sportivi, ospedali, piscine, impianti civili centralizzati,...).



The EVPDC series products are storage tanks for the production and storage of domestic hot water. The heat exchangers used are removable U-shaped tube bundles, made by stainless steel tubes expanded onto steel plates with VITROFLEX treatment. These storage tanks, with high heat exchange capacity and low pressure drop, represents the best compromise between installed power and volume of hot water stored, making them ideal for connection to domestic hot water systems where delivery of hot water has very high peaks (sports centres, hospitals, swimming pools, centralised residential systems,...).

Tutti i serbatoi coibentati rispettano i requisiti richiesti dalle direttive 2009/125/CE e 2010/30/UE sull'efficienza energetica.

All the insulated tanks, comply with the directive 2009/125/CE and 2010/30UE about energy efficiency.

CARATTERISTICHE TECNICHE TECHNICAL FEATURES



Costruzione accumulo <i>Storage tank construction</i>	Acciaio al carbonio di elevata qualità <i>High quality carbon steel</i>
Trattamento interno/esterno <i>Internal/external treatment</i>	VITROFLEX doneo per acqua uso alimentare secondo le direttive CE, D.M. 174/ GREZZO <i>VITROFLEX corrosion-proofing suitable for drinking water in accordance with EC directives / RAW</i>
Isolamento Rimovibile <i>Removable Insulation</i>	ECOFIRE, 800÷1000 lt. spessore 100 mm <i>ECOFIRE, 800÷1000 lt. 100 mm thick</i>
Rivestimento esterno <i>Outside covering</i>	PVC accoppiato <i>Laminated PVC</i>
Accumulo <i>Storage tank</i>	Pmax 10 bar - Tmax 90°C
Scambiatore <i>Heat exchanger</i>	Pmax 12 bar - Tmax 110°C Estraibile acciaio inox <i>Removable stainless steel</i>
Accessori di serie <i>Standard accessories</i>	Anodo/i di magnesio con tester di controllo <i>Magnesium anode/anodes with tester</i>
Garanzia <i>Warranty</i>	3 anni <i>3 years</i>

EVPDC

VETRIFICAZIONE VITRIFICATION

Isolamento rigido spessore 100 mm

Rigid insulation 100 mm thick

	Codice Code		€	Classe Energetica ErP
800	EVPDC800	5		C
1000	EVPDC1000	5		C



Esempio di impianto Example of a system

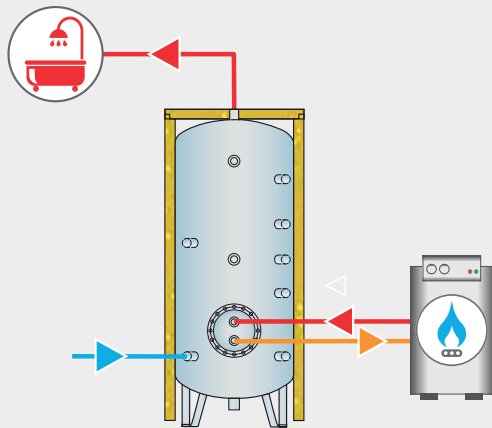

Disegno tecnico Technical drawing

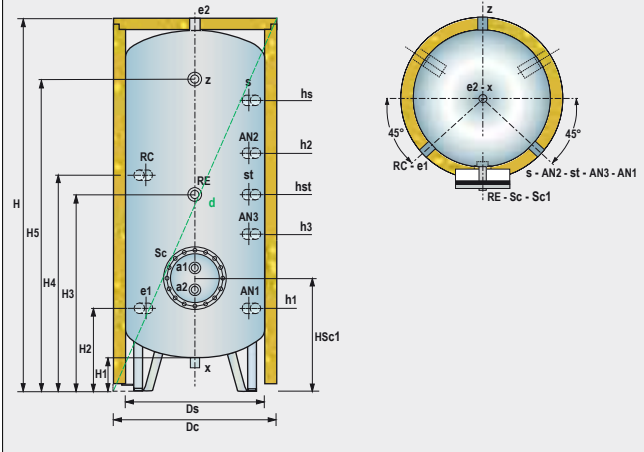

a1	Entrata circuito primario Primary circuit inlet
a2	Uscita circuito primario Primary circuit outlet
e1	Entrata acqua sanitaria Domestic water inlet
e2	Uscita acqua sanitaria Domestic water outlet

AN3	Anodo 300÷800 lt Anode 300÷800 lt
AN1-AN2	Anodi 1000÷5000 lt Anodes 1000÷5000 lt
RE	Attacco resistenza elettrica Electric heater fitting

s	Attacco sonda ausiliaria Auxiliary probe fitting
st	Attacco sonda temperatura Temperature probe fitting
RC	Ricircolo Recirculation
X	Scarico Drain

lt	CONNESSIONI CONNECTIONS										
	a1	a2	e1	e2	AN1÷AN3	RE		s	st	RC	X
800÷1000	G2"-F	G2"-F	G1"1/4"-F	G1"1/2"-F	G1"1/4"-F	G2"-F	430	G1/2"-F	G1/2"-F	G1"-F	G1"1/2

lt	DIMENSIONALE SIZES (mm)														Peso Weight (Kg)	
	Ds	Dc	H	H1	H2	H3	H4	H5	HSc1	Sonde Probes		Anodi Anodes		d		
800	790	990	1940	145	430	1070	1170	-	600	1070	1520	-	-	920	2200	140
1000	790	990	2190	145	430	1070	1170	-	610	1070	1670	420	1370	-	2420	160

PRESTAZIONI PERFORMANCE						
lt						
800	5	80	5360	38	1966	1120
1000	5	80	6880	38	1996	1356

(1) Potenza termica dello scambiatore calcolata ipotizzando una temperatura di ingresso circuito primario di 65°C e di ingresso sanitario di 10°C, temperatura accumulo sanitario 45°C;

(2) Tempo necessario per innalzare la temperatura dell'acqua in ingresso sanitario, 10°C, alla temperatura di accumulo pari a 45°C;

(3) Quantità di acqua calda sanitaria disponibile alla temperatura di utilizzo di 45°C in continuo o nei primi 10 minuti.

(1) Heat exchanger output calculated assuming a primary circuit inlet 65°C and a DHW inlet temperature of 10°C, domestic water storage at 45°C;

(2) Time needed to increase the domestic water inlet temperature, 10°C, to the storage temperature of 45°C;

(3) Quantity of domestic hot water available at a delivery temperature of 45°C, continuously or in the first 10 minutes.

	Capacità accumulo (lt.) Storage tank capacity (lt.)
	Portata primario (l/h) Primary flow-rate (l/h)
	Portata acqua calda sanitaria (l/10') DHW flow-rate in the first 10 min (l/10')

	Superficie di scambio (m²) Heat exchanger surface (m²)
	Tempo di messa a regime (min.) Time to reach temperature (min.)
	Contenuto acqua scambiatore (lt.) Heat exchanger capacity (lt.)

	Potenza di scambio (Kw) Heat exchanger power (Kw)
	Portata ACS (l/h) DHW flow-rate (l/h)
	Diamentro flangia scambiatore Heat exchanger diameter flange



SOL PDC

Bollitore doppio serpentino fisso per POMPA DI CALORE
Calorifier with double fixed coil for HEAT PUMP



I prodotti della serie SOL PDC sono bollitori per la produzione e l'accumulo di acqua calda sanitaria. Lo sviluppo degli scambiatori assicura una elevata resa termica rendendo il bollitore SOL PDC particolarmente adatto per la produzione di acqua calda sanitaria. Infatti, l'elevata potenzialità garantisce la completa copertura di richiesta di acqua anche nei periodi critici di punta. Il doppio scambiatore permette di utilizzare due fonti di energia alternativa.

Lo scambiatore superiore, caratterizzato da una superficie di scambio elevata e da un diametro del tubo maggiore rispetto a qualsiasi altro per pari capacità, è studiato per ottenere le massime prestazioni con calore di integrazione fornito da una pompa di calore. Infatti, le caratteristiche tipiche della pompa di calore sono:

- una temperatura minore di quella di una caldaia;
- un maggior volume di acqua in transito derivante dal minor salto di temperatura (ΔT);
- disponibilità di prevalenza utile modesta, considerata la perdita di carico del condensatore.

Infine, è disponibile un attacco per una eventuale resistenza elettrica.



The SOL PDC series products are storage cylinders for the production and storage of domestic hot water.

The layout of the heat exchangers ensures high heat output, making the SOL PDC storage tank ideal for domestic hot water production.

Indeed, the high output means hot water demand is completely satisfied even at critical peak times.

The double heat exchanger allows two sources of alternative energy to be used.

The top heat exchanger, featuring a high heat exchange area and a higher tube diameter than any other model of the same capacity, is designed to ensure maximum performance, with supplementary heat provided by a heat pump. The typical features of heat pumps are:

- lower temperatures than boilers;
- higher water volume in transit due to lower temperature head (ΔT);
- moderate pressure head, considering the pressure drop of the condenser.

Finally, a fitting is available for an optional electric heater.

Tutti i serbatoi coibentati rispettano i requisiti richiesti dalle direttive 2009/125/CE e 2010/30/UE sull'efficienza energetica.

All the insulated tanks, comply with the directive 2009/125/CE and 2010/30/UE about energy efficiency.

CARATTERISTICHE TECNICHE TECHNICAL FEATURES

Costruzione accumulo <i>Storage tank construction</i>	Acciaio al carbonio di elevata qualità <i>High quality carbon steel</i>
Trattamento interno <i>Inside treatment</i>	Vetrificazione, idoneo per acqua uso alimentare secondo le direttive CE, D.M. 174 <i>Vitrification suitable for drinking water in accordance with EC directives</i>
Isolamento <i>Insulated</i>	Poliuretano rigido iniettato, 300÷500 lt. spessore 50 mm <i>Injected rigid polyurethane, 300÷500 lt. 50 mm thick</i>
Rivestimento esterno <i>Outside covering</i>	PVC accoppiato <i>Laminated PVC</i>
Accumulo <i>Storage tank</i>	Pmax 10 bar - Tmax 99°C
Scambiatore <i>Heat exchanger</i>	Pmax 12 bar - Tmax 110°C
Accessori di serie <i>Standard accessories</i>	Anodo di magnesio <i>Magnesium anode</i>
Garanzia <i>Warranty</i>	5 anni <i>5 years</i>

SOL PDC

VETRIFICAZIONE VITRIFICATION

Isolamento rigido spessore 50 mm

Rigid insulation 50 mm thick

	Codice Code	€	Classe Energética ErP
300	SOLPDC0300		C
500	SOLPDC0500		C

Listino prezzi accessori e ricambi a pagina 116

Accessories and spare parts price list available at page 116

Esempio di impianto Example of a system

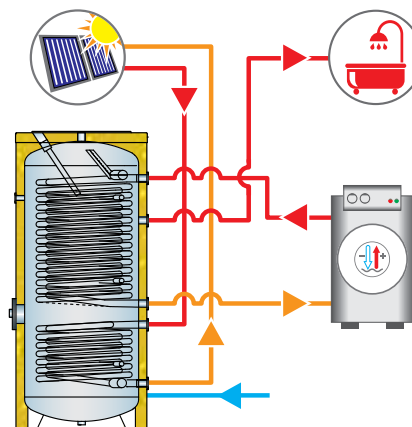

Prodotti conformi alla direttiva 2014/68/UE PED (Art.4 Par.3)

Products complying with the directive 2014/68/UE PED (Art.4 Par.3)



Disegno tecnico Technical drawing

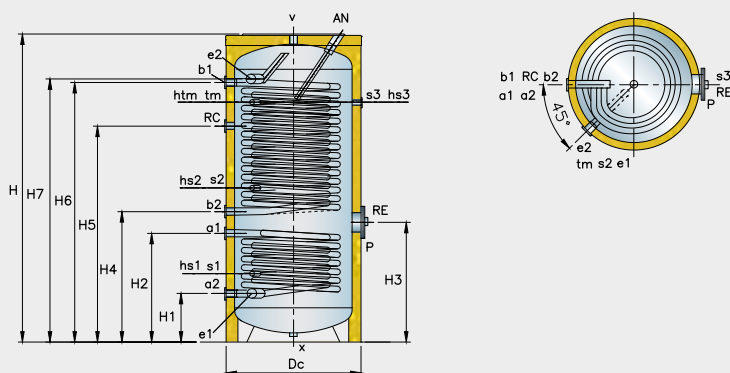

e1	Entrata acqua fredda Cold water inlet
e2	Uscita acqua calda Hot water outlet
tm	Attacco per termostato Thermostat
v	Manicotto fondo superiore Vent
P	Ispezione ø 110/180 Inspection opening
AN	Anodo Anode
RC	Ricircolo Recirculation
RE	Attacco per res. elettrica Electric heater
x	Scarico Drain
s	Sonda Probe
b1-b2	Ingresso / uscita scambiatore superiore Inlet/Outlet upper heat exchanger
a1-a2	Ingresso / uscita scambiatore inferiore Inlet/Outlet lower heat exchanger

lt	CONNESSIONI CONNECTIONS										
	a1-a2	b1-b2	e1-e2	RE	AN	s1-s2-s3	tm	RC	P	v	x
300	G1"-F	G1"-F	G1"-F	G1"1/2-F	G1"1/4-F	G1/2"-F	G1/2"-F	G3/4"-F	øe 180-øi 110	G1"-F	G1"-F
500	G1"-F	G1"-F	G1"1/2-F	G1"1/2-F	G1"1/4-F	G1/2"-F	G1/2"-F	G1"-F	øe 180-øi 110	G1"-F	G1"-F

lt	DIMENSIONALE SIZES (mm)										Peso Weight (Kg)			
	Dc	H	H1	H2	H3	H4	H5	H6	H7	Sonde Probes				
										hs1	hs2	hs3	htm	
300	660	1420	215	455	515	580	1005	1155	1185	325	695	1070	1170	148
500	750	1720	270	605	665	725	1205	1445	1475	380	860	1335	1455	230

lt	PRESTAZIONI PERFORMANCE						
300	1.20	2.70	39	6708	27	1300	338
500	1.80	4.40	62	10664	17	2066	544

- (1) Potenza termica dello scambiatore calcolata ipotizzando una temperatura di ingresso/uscita circuito primario di 55/50°C e di ingresso sanitario di 12°C;
 (2) Tempo necessario per innalzare la temperatura dell'acqua in ingresso sanitario, 15°C, alla temperatura di accumulo pari a 45°C;
 (3) Quantità di acqua calda sanitaria disponibile alla temperatura di utilizzo di 45°C in continuo o nei primi 10 minuti.
 (1) Heat exchanger output calculated assuming a primary circuit inlet/outlet temperature of 55/50°C and a DHW inlet temperature of 12°C;
 (2) Time needed to increase the domestic water inlet temperature, 15°C, to the storage temperature of 45°C;
 (3) Quantity of domestic hot water available at a delivery temperature of 45°C, continuously or in the first 10 minutes.

	Capacità accumulo (lt.) Storage tank capacity (lt.)
	Potenza di scambio (Kw) Heat exchanger power (Kw)
	Portata ACS (l/h) DHW flow-rate (l/h)

	Superficie scambiatore (m²) - inferiore Heat exchanger surface (m²) - bottom
	Portata primario (l/h) Primary flow-rate (l/h)
	Portata acqua calda sanitaria (l/10') DHW flow-rate in the first 10 min (l/10')

	Superficie scambiatore (m²) - superiore Heat exchanger surface (m²) - top
	Tempo di messa a regime (min.) Time to reach temperature (min.)



 I prodotti della serie EV2PDC sono bollitori per la produzione e l'accumulo di acqua calda sanitaria. Gli scambiatori di calore sono a fascio tubiero estraibile, con tubi in acciaio inossidabile mandrinati su piastra in acciaio trattata VITROFLEX. La potenzialità di scambio è la maggiore nella loro categoria e li rendono il compromesso ideale fra potenza installata e volume d'acqua calda accumulato, sono ideali per impianti sanitari ove il prelievo di acqua calda raggiunge punte di richiesta elevate (centri sportivi, ospedali, piscine, impianti civili centralizzati...). Questi modelli offrono, sin dai volumi più piccoli, la possibilità di impiegare due fonti di calore complementari o alternative.

 *The EV2PDC series products are storage tanks for the production and storage of domestic hot water. The heat exchangers used are removable U-shaped tube bundles, made from stainless steel tubes expanded onto steel plates with VITROFLEX treatment. These stand out for their high heat exchange capacity with low pressure drop. These storage tanks represent the best compromise between installed power and volume of hot water stored, making them ideal for connection to domestic hot water systems where delivery of hot water has very high peaks (sports centres, hospitals, swimming pools, centralised residential systems, etc.). On the versions with dual heat exchanger, two complementary or alternative heat sources can be used.*

Tutti i serbatoi coibentati rispettano i requisiti richiesti dalle direttive 2009/125/CE e 2010/30/UE sull'efficienza energetica.

All the insulated tanks, comply with the directive 2009/125/CE and 2010/30UE about energy efficiency.



CARATTERISTICHE TECNICHE TECHNICAL FEATURES

Costruzione accumulo <i>Storage tank construction</i>	Acciaio al carbonio di elevata qualità <i>High quality carbon steel</i>
Trattamento interno <i>Inside treatment</i>	VITROFLEX idoneo per acqua uso alimentare secondo le direttive CE, D.M. 174/ GREZZO <i>VITROFLEX corrosion-proofing suitable for drinking water in accordance with EC directives / RAW</i>
Isolamento <i>Insulated</i>	ECOFIRE, 800÷1000 lt. spessore 100 mm <i>ECOFIRE, 800÷1000 lt. 100 mm thick</i>
Rivestimento esterno <i>Outside covering</i>	PVC accoppiato <i>Laminated PVC</i>
Accumulo <i>Storage tank</i>	Pmax 10 bar - Tmax 99°C
Scambiatore <i>Heat exchanger</i>	Pmax 12 bar - Tmax 110°C Estraibile acciaio inox <i>Removable stainless steel</i>
Accessori di serie <i>Standard accessories</i>	Anodo/i di magnesio con tester di controllo - Gruppo di scarico <i>Magnesium anode/anodes with tester - Drain assembly</i>
Garanzia <i>Warranty</i>	3 anni <i>3 years</i>

EV2PDC

VETRIFICAZIONE VITRIFICATION

Isolamento rigido spessore 100 mm
Rigid insulation 100 mm thick

 lt	Codice Code	 m ²	€	Classe Energetica ErP
800	EV2PDC0800	5+2		C
1000	EV2PDC1000	5+3		C

Esempio di impianto Example of a system

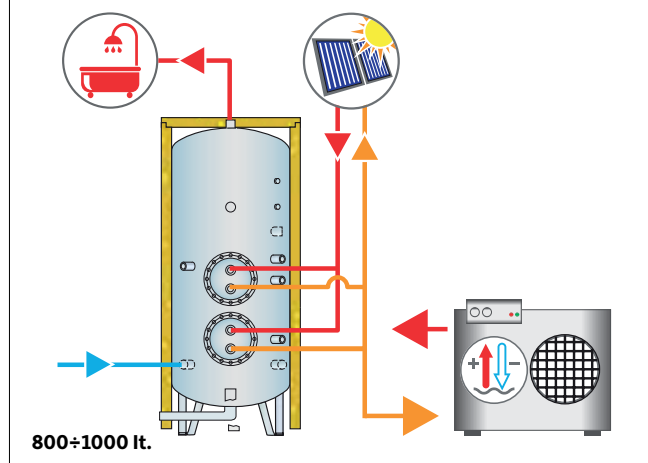





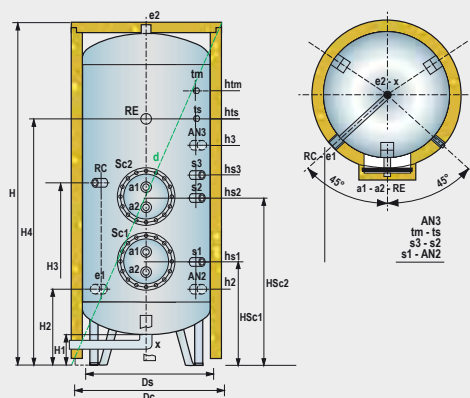



Disegno tecnico Technical drawing



a1-b1	Entrata circuito primario Primary circuit inlet
a2-b2	Uscita circuito primario Primary circuit outlet
e1	Entrata acqua sanitaria Domestic water inlet
e2	Uscita acqua sanitaria Domestic water outlet
AN1+AN3	Anodo Anode
RE	Attacco resistenza elettrica Electric heater fitting
s1+s3	Attacco sonda ausiliaria Auxiliary probe fitting
ts	Attacco termostato Temperature probe fitting
tm	Attacco sonda temperatura Temperature probe fitting
RC	Ricircolo Recirculation
X	Scarico Drain

lt	CONNESSIONI CONNECTIONS												SC1	SC2
	a1	a2	e1	e2	AN1+AN3	RE	s1+s3	ts	tm	RC	X			
800+1000	G2"-F	G2"-F	G1"1/4-F	G1"1/2-F	G1"1/4-F	G2"-F	G1/2"-F	G1/2"-F	G 1/2"-F	G1"-F	G1"1/4-F	380	430	

lt	DIMENSIONALE SIZES (mm)																	Peso Weight (Kg)	
	Ds	Dc	H	H1	H2	H3	H4	HSc1	HSc2	Sonde Probes					Anodi Anodes				d
										hs1	hs2	hs3	hts	htm	h1	h2	h3		
800	790	990	1940	145	430	1070	1170	600	1030	585	1045	-	1370	1520	920	-	-	220	185
1000	790	990	2190	145	445	1170	1570	655	1115	655	1040	-	1370	1720	-	420	1170	2420	220

lt	PRESTAZIONI PERFORMANCE					
	 m ²	 KW ⁽¹⁾	 l/h	 min ⁽²⁾	 l/h ⁽³⁾	 l/10' ⁽³⁾
800	5+2	128	9052	26	4743	1154
1000	5+3	135	11008	29	5994	1454

(1) Potenza termica dello scambiatore calcolata ipotizzando una temperatura di ingresso circuito primario di 65°C e di ingresso sanitario di 10°C, temperatura accumulo sanitario 45°C;

(2) Tempo necessario per innalzare la temperatura dell'acqua in ingresso sanitario, 10°C, alla temperatura di accumulo pari a 45°C;

(3) Quantità di acqua calda sanitaria disponibile alla temperatura di utilizzo di 45°C in continuo o nei primi 10 minuti.

(1) Heat exchanger output calculated assuming a primary circuit inlet 65°C and a DHW inlet temperature of 10°C, domestic water storage at 45°C;

(2) Time needed to increase the domestic water inlet temperature, 10°C, to the storage temperature of 45°C;

(3) Quantity of domestic hot water available at a delivery temperature of 45°C, continuously or in the first 10 minutes.



CAL

Bollitore solare con serpentino spiroidale fisso
Solar storage tank with fixed spiral coil



I prodotti della serie CAL sono bollitori per la produzione e l'accumulo di acqua calda sanitaria. Le spire inferiori dello scambiatore arrivano fino alla parte più bassa del bollitore riscaldando così una maggiore quantità di acqua.



The CAL series products are storage tanks for the production and storage of domestic hot water. The bottom coil of the heat exchanger runs down to the bottom of the storage tank, thus heating a higher volume of water.

Tutti i serbatoi coibentati rispettano i requisiti richiesti dalle direttive 2009/125/CE e 2010/30/UE sull'efficienza energetica.

All the insulated tanks, comply with the directive 2009/125/CE and 2010/30/UE about energy efficiency.

CARATTERISTICHE TECNICHE TECHNICAL FEATURES

Costruzione accumulo <i>Storage tank construction</i>	Acciaio al carbonio di elevata qualità <i>High quality carbon steel</i>
Trattamento interno <i>Inside treatment</i>	Vetrificazione, idoneo per acqua uso alimentare secondo le direttive CE, D.M. 174 <i>Vitrification suitable for drinking water in accordance with EC directives</i>
Isolamento <i>Insulated</i>	Poliuretano rigido iniettato, spessore 50 mm <i>Injected rigid polyurethane, 50 mm thick</i>
Rivestimento esterno <i>Outside covering</i>	PVC accoppiato <i>Laminated PVC</i>
Accumulo <i>Storage tank</i>	Pmax 10 bar - Tmax 95°C
Scambiatore <i>Heat exchanger</i>	Pmax 12 bar - Tmax 110°C
Accessori di serie <i>Standard accessories</i>	Anodo di magnesio <i>Magnesium anode</i>
Garanzia <i>Warranty</i>	5 anni <i>5 years</i>

CAL

VETRIFICAZIONE VITRIFICATION

Isolamento rigido spessore 50 mm

Rigid insulation 50 mm thick

	Codice Code	€	Classe Energetica ErP
200	CAL0200IN		C
300	CAL0300IN		C
500	CAL0500IN		C

Listino prezzi accessori e ricambi a pagina 116

Accessories and spare parts price list available at page 116

Esempio di impianto Example of a system

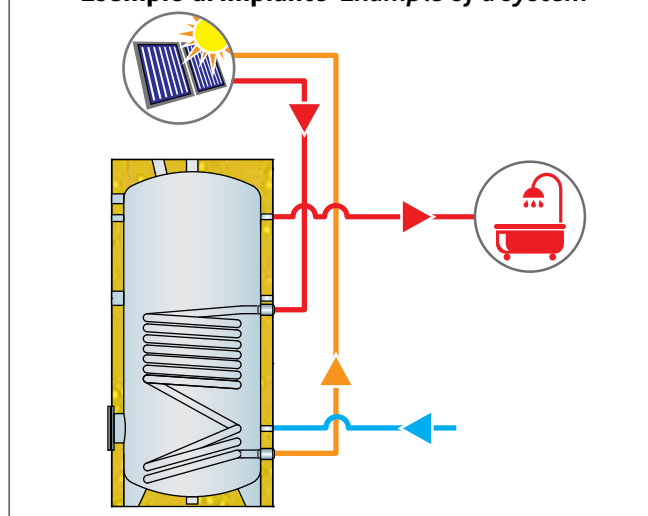

Prodotti conformi alla direttiva 2014/68/UE PED (Art.4 Par.3)

Products complying with the directive 2014/68/UE PED (Art.4 Par.3)

Usò: acqua calda sanitaria
Use: domestic hot water

Abbinabile con:
Combined with:



Disegno tecnico Technical drawing

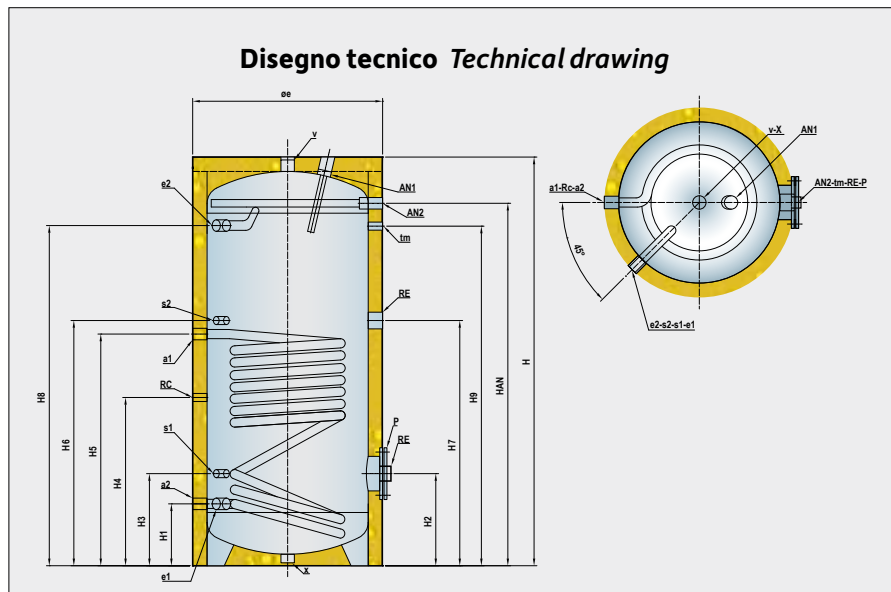

v	Ausiliario Auxiliary fitting
e1	Ingresso acqua sanitaria Domestic water circuit inlet
e2	Uscita acqua calda sanitaria Domestic hot water circuit outlet
s1-s2	Sonda Probe
a1-a2	Ingresso / Uscita circuito solare Solar circuit inlet / outlet
RC	Ricircolo Recirculation
tm	Sonda Probe
RE	Attacco resistenza elettrica (solo integrazione) Electric heater fitting (only integration)
AN1	Anodo 150-200-300 LT Anode 150-200-300 LT
AN2	Anodo 400-500 LT Anode 400-500 LT
P	Flangia di ispezione Inspection opening
x	Scarico Drain

lt	CONNESSIONI CONNECTIONS									
	e1-e2	a1-a2	v	AN1	AN2	RE	RC	s1-s2-tm	x	P
200	G1"-F	G1"-F	G1"-F	G1"1/4-F	-	G1"1/2-F	G3/4"-F	G1/2"-F	G1"-F	ø110/180
300	G1"-F	G1"-F	G1"-F	G1"1/4-F	-	G1"1/2-F	G3/4"-F	G1/2"-F	G1"-F	ø110/180
500	G1"1/2-F	G1"-F	G1"-F	-	G1"1/4-F	G1"1/2-F	G3/4"-F	G1/2"-F	G1"-F	ø110/180

lt	DIMENSIONALE SIZES (mm)												Peso Weight (Kg)
	ø est	H	H1	H2	H3	H4	H5	H6	H7	H8	H9	HAN	
200	560	1340	202	309	392	500	692	892	850	1340	1340	-	73
300	660	1420	215	320	407	663	805	897	950	1165	1170	-	104
500	750	1720	270	450	568	831	960	1168	1130	1453	1453	1340	167

lt	PRESTAZIONI PERFORMANCE					
	m ²	KW	l/h	min	l/h	l/10'
200	0.90	27	2322	30	704	250
300	1.20	36	3096	33	938	293
500	1.80	53	4558	38	1381	457

(1) Potenza termica dello scambiatore calcolata ipotizzando una temperatura di ingresso/uscita circuito primario di 80/70°C e di ingresso sanitario di 12°C;

(2) Tempo necessario per innalzare la temperatura dell'acqua in ingresso sanitario, 12°C, alla temperatura di accumulo pari a 60°C;

(3) Quantità di acqua calda sanitaria disponibile alla temperatura di utilizzo di 45°C in continuo o nei primi 10 minuti.

(1) Heat exchanger output calculated assuming a primary circuit inlet/outlet temperature of 80/70°C and a DHW inlet temperature of 12°C;

(2) Time needed to increase the domestic water inlet temperature, 12°C, to the storage temperature of 60°C;

(3) Quantity of domestic hot water available at a delivery temperature of 45°C, continuously or in the first 10 minutes.

lt	Capacità accumulo (lt.) Storage tank capacity (lt.)
l/h	Portata primario (l/h) Primary flow-rate (l/h)
l/10'	Portata acqua calda sanitaria (l/10') DHW flow-rate in the first 10 min (l/10')

m ²	Superficie scambiatore (m ²) - inferiore Heat exchanger surface (m ²) - bottom
min	Tempo di messa a regime (min.) Time to reach temperature (min.)

KW	Potenza di scambio (Kw) Heat exchanger power (Kw)
l/h	Portata ACS (l/h) DHW flow-rate (l/h)



SOL

Bollitore solare con doppio serpentino spiroidale fisso
Solar storage tank with double fixed spiral coil



I prodotti della serie SOL sono bollitori per la produzione e l'accumulo di acqua calda sanitaria. Il doppio scambiatore permette di utilizzare, oltre alla caldaia tradizionale, una fonte di energia alternativa quale quella solare ma non solo. Lo scambiatore inferiore si sviluppa fino alla parte più bassa del bollitore riscaldando così una maggiore quantità di acqua.



The SOL series products are storage cylinders for the production and storage of domestic hot water. The layout of the heat exchangers ensures high heat output. The double heat exchanger allows a source of alternative energy to be used in addition to a traditional boiler.

Tutti i serbatoi coibentati rispettano i requisiti richiesti dalle direttive 2009/125/CE e 2010/30/UE sull'efficienza energetica.
All the insulated tanks, comply with the directive 2009/125/CE and 2010/30UE about energy efficiency.

CARATTERISTICHE TECNICHE TECHNICAL FEATURES

Costruzione accumulo <i>Storage tank construction</i>	Acciaio al carbonio di elevata qualità <i>High quality carbon steel</i>
Trattamento interno <i>Inside treatment</i>	Vetrificazione, idoneo per acqua uso alimentare secondo le direttive CE, D.M. 174 <i>Vitrification suitable for drinking water in accordance with EC directives</i>
Isolamento <i>Insulated</i>	Poliuretano rigido iniettato, spessore 50 mm <i>Injected rigid polyurethane, 50 mm thick</i>
	ECOFIRE RIMOVIBILE, 800÷1000 lt. spessore 100 mm <i>ECOFIRE REMOVABLE, 800÷1000 lt. 100 mm thick</i>
Rivestimento esterno <i>Outside covering</i>	PVC accoppiato <i>Laminated PVC</i>
Accumulo <i>Storage tank</i>	Pmax 10 bar - Tmax 95°C
Scambiatore <i>Heat exchanger</i>	Pmax 12 bar - Tmax 110°C
Accessori di serie <i>Standard accessories</i>	Anodo di magnesio <i>Magnesium anode</i>
Garanzia <i>Warranty</i>	5 anni <i>5 years</i>

Esempio di impianto Example of a system

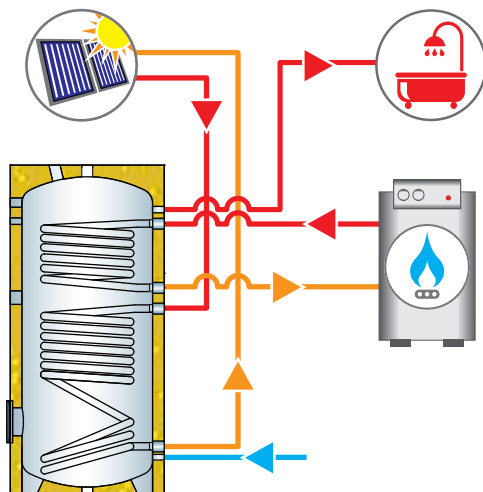

SOL

VETRIFICAZIONE VITRIFICATION

Isolamento rigido spessore 50 mm
Rigid insulation 50 mm thick

	Codice Code	€	Classe Energetica ErP
200	SOL0200IN		C
300	SOL0300IN		C
500	SOL0500IN		C

Isolamento flessibile spessore 100 mm
Flexible insulation 100 mm thick

	Codice Code	€	Classe Energetica ErP
800	SOL0800IN		C
1000	SOL1000IN		C

Usò: acqua calda sanitaria
Use: domestic hot water

Abbinabile con:
Combined with:

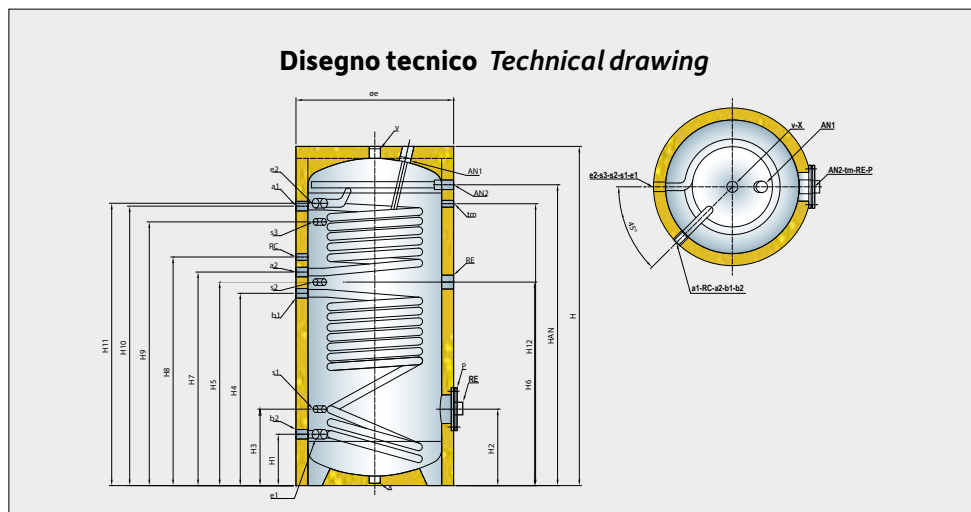

v	Ausiliario Auxiliary fitting
e1	Ingresso acqua sanitaria Domestic water circuit inlet
e2	Uscita acqua calda sanitaria Domestic hot water circuit outlet
s1-s2-s3	Sonda Probe
a1-a2	Ingresso / uscita circuito primario Primary circuit inlet / outlet
b1-b2	Ingresso / uscita circuito solare Solar circuit inlet / outlet
RC	Ricircolo Recirculation
tm	Sonda Probe
RE	Attacco resistenza elettrica (solo integrazione) Electric heater fitting (only integration)
AN1	Anodo 200-300 LT Anode 200-300 LT
AN2	Anodo 400-1000 LT Anode 400-1000 LT
P	Flangia di ispezione Inspection opening
x	Scarico Drain

lt	CONNESSIONI CONNECTIONS									
	e1-e2	a1-a2	b1-b2	v-x	AN1	AN2	RE	RC	s1-s2 s3-tm	P
200	G1"-F	G1"-F	G1"-F	G1"-F	G1"1/4-F	-	G1"1/2-F	G3/4"-F	G1/2"-F	ø110/180
300	G1"-F	G1"-F	G1"-F	G1"-F	G1"1/4-F	-	G1"1/2-F	G3/4"-F	G1/2"-F	ø110/180
500	G1"1/2-F	G1"-F	G1"-F	G1"-F	-	G1"1/4-F	G1"1/2-F	G1"-F	G1/2"-F	ø110/180
800÷1000	G1"1/2-F	G1"-F	G1"-F	G1"-F	-	G1"1/4-F	G1"1/2-F	G1"-F	G1/2"-F	Ø200/280

lt	DIMENSIONALE SIZES (mm)															Peso Weight (Kg)
	ø est	H	H1	H2	H3	H4	H5	H6	H7	H8	H9	H10	H11	H12	HAN	
200	560	1340	202	309	302	692	752	752	812	987	1037	1112	1168	1138	-	82
300	660	1420	215	320	320	805	852	852	894	957	1104	1170	1182	1170	-	118
500	750	1720	270	450	450	960	1011	1011	1062	1206	1206	1350	1453	1453	1568	185
800	950	2000	410	440	530	765	920	995	1070	1385	1540	555	1225	1535	1460	260
1000	1050	2050	410	440	530	765	920	995	1070	1385	1790	555	1225	1805	1460	315

lt	PRESTAZIONI PERFORMANCE						
200	0.90	0.60	41	3526	20	1068	269
300	1.20	0.90	56	4816	22	1459	380
500	1.80	1.20	73	6278	28	1902	544
800	2.10	1.40	108	9288	30	2815	833
1000	2.70	1.90	108	9288	37	2815	924

(1) Potenza termica dello scambiatore calcolata ipotizzando una temperatura di ingresso/uscita circuito primario di 80/70°C e di ingresso sanitario di 12°C;
 (2) Tempo necessario per innalzare la temperatura dell'acqua in ingresso sanitario, 12°C, alla temperatura di accumulo pari a 60°C;
 (3) Quantità di acqua calda sanitaria disponibile alla temperatura di utilizzo di 45°C in continuo o nei primi 10 minuti.

(1) Heat exchanger output calculated assuming a primary circuit inlet/outlet temperature of 80/70°C and a DHW inlet temperature of 12°C;
 (2) Time needed to increase the domestic water inlet temperature, 12°C, to the storage temperature of 60°C;
 (3) Quantity of domestic hot water available at a delivery temperature of 45°C, continuously or in the first 10 minutes.

	Capacità accumulo (lt.) Storage tank capacity (lt.)
	Potenza di scambio (Kw) Heat exchanger power (Kw)
	Portata ACS (l/h) DHW flow-rate (l/h)

	Superficie scambiatore (m²) - inferiore Heat exchanger surface (m²) - bottom
	Portata primario (l/h) Primary flow-rate (l/h)
	Portata acqua calda sanitaria (l/10') DHW flow-rate in the first 10 min (l/10')

	Superficie scambiatore (m²) - superiore Heat exchanger surface (m²) - top
	Tempo di messa a regime (min.) Time to reach temperature (min.)



I prodotti della serie NS1 sono bollitori per la produzione e l'accumulo di acqua calda sanitaria. Lo scambiatore di calore è a fascio tubiero estraibile, con tubi in acciaio inossidabile mandrinati su piastra in acciaio trattata VITROFLEX. La potenzialità di scambio è la maggiore nella loro categoria e li rendono il compromesso ideale fra potenza installata e volume d'acqua calda accumulato, sono ideali per impianti sanitari ove il prelievo di acqua calda raggiunge punte di richiesta elevate (centri sportivi, ospedali, piscine, impianti civili centralizzati...).



The NS1 series products are storage tanks for the production and storage of domestic hot water. The heat exchanger used is removable U-shaped tube bundles, made from stainless steel tubes expanded onto steel plates with VITROFLEX treatment. These stand out for their high heat exchange capacity with low pressure drop. These storage tanks represent the best compromise between installed power and volume of hot water stored, making them ideal for connection to domestic hot water systems where delivery of hot water has very high peaks (sports centres, hospitals, swimming pools, centralised residential systems, etc.).

Tutti i serbatoi coibentati rispettano i requisiti richiesti dalle direttive 2009/125/CE e 2010/30/UE sull'efficienza energetica.

All the insulated tanks, comply with the directive 2009/125/CE and 2010/30UE about energy efficiency.

CARATTERISTICHE TECNICHE TECHNICAL FEATURES

Costruzione accumulo <i>Storage tank construction</i>	Acciaio al carbonio di elevata qualità <i>High quality carbon steel</i>
Trattamento interno <i>Inside treatment</i>	VITROFLEX idoneo per acqua uso alimentare secondo le direttive CE, D.M. 174/ GREZZO <i>VITROFLEX corrosion-proofing suitable for drinking water in accordance with EC directives / RAW</i>
Isolamento rimovibile <i>Removable insulation</i>	ECOFIRE, 200÷1000 lt. spessore 100 mm <i>ECOFIRE, 200÷1000 lt. 100 mm thick</i>
Rivestimento esterno <i>Outside covering</i>	PVC accoppiato <i>Laminated PVC</i>
Accumulo <i>Storage tank</i>	Pmax 8 bar - Tmax 90°C
Scambiatore <i>Heat exchanger</i>	Pmax 12 bar - Tmax 110°C Estraibile acciaio inox <i>Removable stainless steel</i>
Accessori di serie <i>Standard accessories</i>	Anodo/i di magnesio con tester di controllo - Gruppo di scarico <i>Magnesium anode/anodes with tester - Drain assembly</i>
Garanzia <i>Warranty</i>	5 anni <i>5 years</i>

Flangia superiore cieca predisposta per l'inserimento di uno scambiatore aggiuntivo

Top Flange with blind suitable to allocate a second heat exchanger

Uso: acqua calda sanitaria
Use: domestic hot water

Abbinabile con:
Combined with:



Esempio di impianto Example of a system

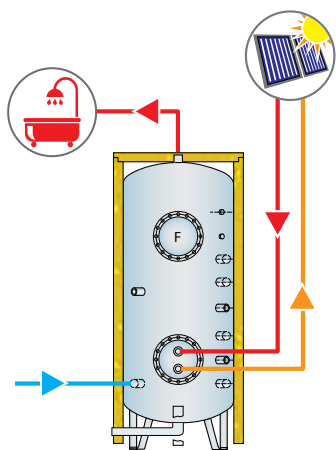

Disegno tecnico Technical drawing

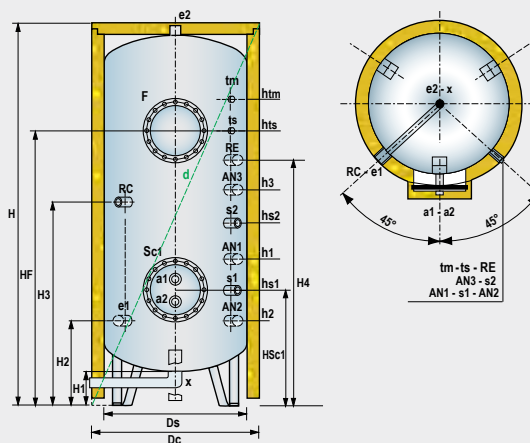

a1	Entrata circuito primario Primary circuit inlet
a2	Uscita circuito primario Primary circuit outlet
e1	Entrata acqua sanitaria Domestic water inlet
e2	Uscita acqua sanitaria Domestic water outlet

AN1÷AN3	Anodo Anode
RE	Attacco resistenza elettrica Electric heater fitting
s1÷s3	Attacco sonda ausiliaria Auxiliary probe fitting
ts	Attacco termostato Temperature probe fitting

tm	Attacco sonda temperatura Temperature probe fitting
RC	Ricircolo Recirculation
X	Scarico Drain

lt	CONNESSIONI CONNECTIONS										
	a1	a2	e1	e2	AN1÷AN3	RE	s1÷s3	ts	tm	RC	X
200	G1"-F	G1"-F	G1"-F	G1" 1/2-F	G1" 1/4-F	G2"-F	G 1/2"-F	G 1/2"-F	G 1/2"-F	G1"-F	G1" 1/4-F
300÷800	G2"-F	G2"-F	G1"1/4-F	G1" 1/2-F	G1" 1/4-F	G2"-F	G 1/2"-F	G 1/2"-F	G 1/2"-F	G1"-F	G1" 1/4-F
1000	G2"-F	G2"-F	G1"1/4-F	G1" 1/2-F	G1" 1/4-F	G2"-F	G 1/2"-F	G 1/2"-F	G 1/2"-F	G1"-F	G1" 1/4-F

lt	DIMENSIONALE SIZES (mm)																Peso Weight (Kg)	
	Ds	Dc	H	H1	H2	H3	H4	HF	HSc1	Sonde Probes				Anodi Anodes				d
										hs1	hs2	hts	htm	h1	h2	h3		
200	450	650	1570	180	375	925	975	1125	475	475	825	1125	1275	695	-	-	1810	70
300	550	750	1580	165	390	930	980	1130	525	525	830	1130	1280	700	-	-	1770	100
500	650	850	1895	155	410	1050	1190	1350	540	540	950	1350	1500	720	-	-	2095	130
800	790	990	1940	145	430	1070	1170	1370	585	585	1045	1370	1520	920	-	-	2200	170
1000	790	990	2190	145	445	1170	1570	1370	655	655	1040	1370	1720	-	420	1170	2420	195



lt	PRESTAZIONI PERFORMANCE					
	m ²	⁽¹⁾ KW	1 l/h	⁽²⁾ min	⁽³⁾ l/h	⁽³⁾ l/10'
200	1	32	2752	25	834	230
300	2	74	6364	16	1929	458
500	3	94	8084	21	2450	636
800	4	150	12900	21	3909	1015
1000	5	174	14964	23	4535	1210

(1) Potenza termica dello scambiatore calcolata ipotizzando una temperatura di ingresso/uscita circuito primario di 80/70°C e di ingresso sanitario di 12°C

(2) Tempo necessario per innalzare la temperatura dell'acqua in ingresso sanitario, 12°C, alla temperatura di accumulo pari a 60°C.

(3) Quantità di acqua calda sanitaria disponibile alla temperatura di utilizzo di 45°C in continuo o nei primi 10 minuti.

(1) Heat exchanger output calculated assuming a primary circuit inlet/outlet temperature of 80/70°C and a DHW inlet temperature of 12°C.

(2) Time needed to increase the domestic water inlet temperature, 12°C, to the storage temperature of 60°C.

(3) Quantity of domestic hot water available at a delivery temperature of 45°C, continuously or in the first 10 minutes.

TABELLA SCAMBIATORI HEAT EXCHANGER TABLE										
lt	200		300		500		800		1000	
Di serie Standard (m ²)	Sc1	F	Sc1	F	Sc1	F	Sc1	F	Sc1	F
	1	-	2	-	3	-	4	-	5	-
Optional (m ²)	0.75	0.75	-	0.75	1.5	0.75	-	0.75	4	1.5
		1		1	2	1	-	1		2
										3

DATI SCAMBIATORI HEAT EXCHANGER DATA							
m ²	0.75	1	1.5	2	3	4	5
KW	27	32	56	74	94	150	174
lt	4	5	8.5	10.5	14	19	22
mm	300	300	380	380	380	430	430

	Capacità accumulo (lt.) Storage tank capacity (lt.)
	Portata primario (l/h) Primary flow-rate (l/h)
	Portata ACS nei primi 10 min. DHW flow-rate in the first 10 min.

	Superficie di scambio (m ²) Heat exchanger surface (m ²)
	Tempo di messa a regime (min.) Time to reach temperature (min.)
	Contenuto acqua scambiatore (lt.) Heat exchanger capacity (lt.)

	Potenza di scambio (Kw) Heat exchanger power (Kw)
	Portata ACS (l/h) DHW flow-rate (l/h)
	Diametro flangia scambiatore Heat exchanger diameter flange

Uso: acqua calda sanitaria
Use: domestic hot water

Abbinabile con:
Combined with:





NS1XX

VITROFLEX

Isolamento flessibile spessore **100 mm**

Flexible insulation **100 mm** thick

	Codice Code		€	Classe Energetica ErP
200	NSXX0200	1		C
300	NSXX0300	2		C
500	NSXX0500	3		C
800	NSXX0800	4		C
1000	NSXX1000	5		C

Listino prezzi accessori e ricambi a pagina 116

Accessories and spare parts price list available at page 116

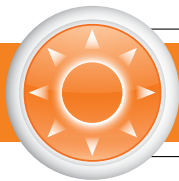

NS2

Bollitore solare con DUE scambiatori estraibili
Solar storage tank with TWO removable heat exchangers



200÷1000 lt.

1500÷5000 lt.



I prodotti della serie NS2 sono bollitori per la produzione e l'accumulo di acqua calda sanitaria. Gli scambiatori di calore sono a fascio tubiero estraibile, con tubi in acciaio inossidabile mandrinati su piastra in acciaio trattata VITROFLEX. La potenzialità di scambio è la maggiore nella loro categoria e li rendono il compromesso ideale fra potenza installata e volume d'acqua calda accumulato, sono ideali per impianti sanitari ove il prelievo di acqua calda raggiunge punte di richiesta elevate (centri sportivi, ospedali, piscine, impianti civili centralizzati...). Questi modelli offrono, in dai volumi più piccoli, la possibilità di impiegare due fonti di calore complementari o alternative.



The NS2 series products are storage tanks for the production and storage of domestic hot water. The heat exchangers used are removable U-shaped tube bundles, made from stainless steel tubes expanded onto steel plates with VITROFLEX treatment. These stand out for their high heat exchange capacity with low pressure drop. These storage tanks represent the best compromise between installed power and volume of hot water stored, making them ideal for connection to domestic hot water systems where delivery of hot water has very high peaks (sports centres, hospitals, swimming pools, centralised residential systems, etc.). On the versions with dual heat exchanger, two complementary or alternative heat sources can be used.

Tutti i serbatoi coibentati rispettano i requisiti richiesti dalle direttive 2009/125/CE e 2010/30/UE sull'efficienza energetica.

All the insulated tanks, comply with the directive 2009/125/CE and 2010/30UE about energy efficiency.

CARATTERISTICHE TECNICHE TECHNICAL FEATURES

Costruzione accumulo <i>Storage tank construction</i>	Acciaio al carbonio di elevata qualità <i>High quality carbon steel</i>
Trattamento interno <i>Inside treatment</i>	VITROFLEX idoneo per acqua uso alimentare secondo le direttive CE, D.M. 174/ GREZZO <i>VITROFLEX corrosion-proofing suitable for drinking water in accordance with EC directives / RAW</i>
Isolamento rimovibile <i>Removable insulation</i>	ECOFIRE, 200÷1000 lt. spessore 100 mm <i>ECOFIRE, 200÷1000 lt. 100 mm thick</i>
	ECOFIRE, 1500÷2000 lt. spessore 130 mm <i>ECOFIRE, 1500÷2000 lt. 130 mm thick</i>
	ECOFIRE, 3000÷5000 lt. spessore 100 mm <i>ECOFIRE, 3000÷5000 lt. 100 mm thick</i>
Rivestimento esterno <i>Outside covering</i>	PVC accoppiato <i>Laminated PVC</i>
Accumulo <i>Storage tank</i>	Pmax 8 bar - Tmax 90°C
Scambiatore <i>Heat exchanger</i>	Pmax 12 bar - Tmax 110°C Estraibile acciaio inox <i>Removable stainless steel</i>
Accessori di serie <i>Standard accessories</i>	Anodo/i di magnesio con tester di controllo - Gruppo di scarico <i>Magnesium anode/anodes with tester - Drain assembly</i>
Garanzia <i>Warranty</i>	5 anni <i>5 years</i>

Esempio di impianto Example of a system

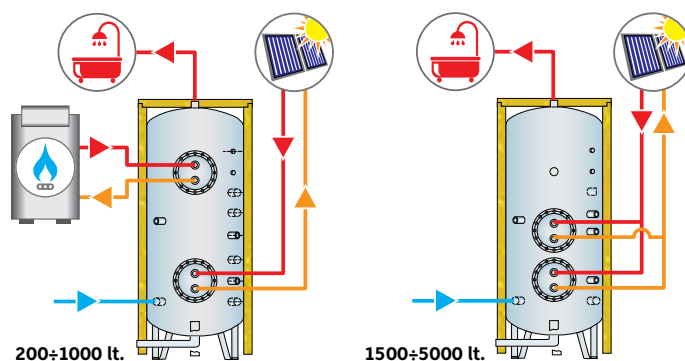

200÷1000 lt.

1500÷5000 lt.

Uso: acqua calda sanitaria
Use: domestic hot water

Abbinabile con:
Combined with:



Disegno tecnico Technical drawing

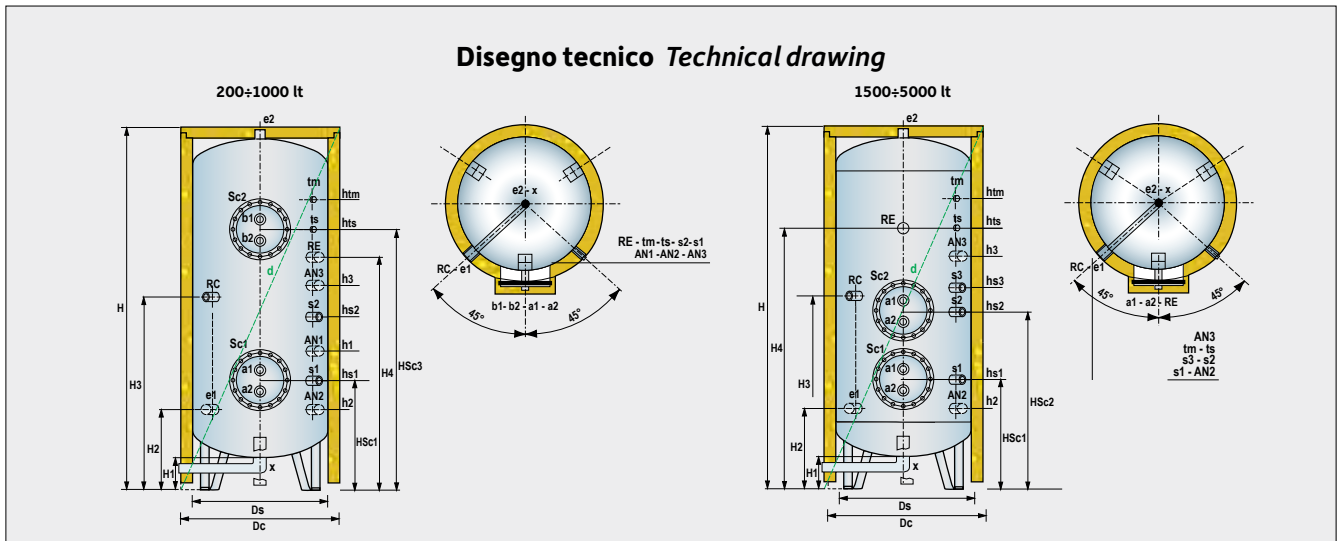

a1-b1	Entrata circuito primario Primary circuit inlet
a2-b2	Uscita circuito primario Primary circuit outlet
e1	Entrata acqua sanitaria Domestic water inlet
e2	Uscita acqua sanitaria Domestic water outlet

AN1÷AN3	Anodo Anode
RE	Attacco resistenza elettrica Electric heater fitting
s1+s3	Attacco sonda ausiliaria Auxiliary probe fitting
ts	Attacco termostato Temperature probe fitting

tm	Attacco sonda temperatura Temperature probe fitting
RC	Ricircolo Recirculation
X	Scarico Drain

lt	CONNESSIONI CONNECTIONS										
	a1	a2	e1	e2	AN1÷AN3	RE	s1÷s3	ts	tm	RC	X
200	G1"-F	G1"-F	G1"-F	G1" 1/2-F	G1" 1/4-F	G2"-F	G 1/2"-F	G 1/2"-F	G 1/2"-F	G1"-F	G1" 1/4-F
300÷800	G2"-F	G2"-F	G1"1/4-F	G1" 1/2-F	G1" 1/4-F	G2"-F	G 1/2"-F	G 1/2"-F	G 1/2"-F	G1"-F	G1" 1/4-F
1000	G2"-F	G2"-F	G1"1/4-F	G1" 1/2-F	G1" 1/4-F	G2"-F	G 1/2"-F	G 1/2"-F	G 1/2"-F	G1"-F	G1" 1/4-F
1500÷5000	G2"-F	G2"-F	G3"-F	G3"-F	G1" 1/4-F	G2"-F	G 1/2"-F	G 1/2"-F	G 1/2"-F	G1"-F	G3"-F

lt	DIMENSIONALE SIZES (mm)																			Peso Weight (Kg)
	Ds	Dc NS2 XX	H	H1	H2	H3	H4	HSc1	HSc2	HSc3	Sonde Probes				Anodi Anodes			d		
											hs1	hs2	hs3	hts	htm	h1	h2		h3	
200	450	650	1570	180	375	925	975	475	-	1125	475	825	-	1125	1275	695	-	-	1810	85
300	550	750	1580	165	390	930	980	525	-	1130	525	830	-	1130	1280	700	-	-	1770	115
500	650	850	1895	155	410	1050	1190	540	-	1350	540	950	-	1350	1500	720	-	-	2095	145
800	790	990	1940	145	430	1070	1170	585	-	1370	585	1045	-	1370	1520	920	-	-	2200	185
1000	790	990	2190	145	445	1170	1570	655	-	1370	655	1040	-	1370	1720	-	420	1170	2420	220
1500	950	1210	2530	185	485	1310	1710	-	695	1150	695	1150	1285	1710	1960	-	460	1510	2850	325
2000	1100	1360	2580	170	495	1320	1720	-	705	1205	705	1205	1340	1720	1970	-	470	1520	2975	385
3000	1250	1450	2795	150	520	1345	1945	-	730	1230	730	1230	1365	1945	2245	-	495	1745	3170	445
4000	1400	1600	2895	155	565	1385	2035	-	770	1270	770	1270	1405	2035	2285	-	535	1785	3330	645
5000	1600	1800	2930	130	580	1400	2050	-	785	1285	785	1285	1420	2050	2300	-	550	1800	3460	745

Prodotti conformi alla direttiva 2014/68/UE PED (Art.4 Par.3)
Products complying with the directive 2014/68/UE PED (Art.4 Par.3)



lt	PRESTAZIONI PERFORMANCE					
	m ²	KW ⁽¹⁾	l/h	min ⁽²⁾	l/h ⁽³⁾	l/10' ⁽³⁾
200	1 + 0.75	59	5074	14	1538	347
300	2 + 0.75	101	8600	12	2606	571
500	3 + 1	126	10836	16	3284	775
800	4 + 1	182	15652	18	4743	1154
1000	5 + 1.5	230	19780	17	5994	1454
1500	4+3	244	20984	25	6359	1742
2000	4+4	300	25800	27	7818	2212
3000	6+6	400	34400	30	10424	3101
4000	8+8	578	49709	28	15063	4329
5000	10+10	672	57793	30	17513	5192

(1) Heat exchanger output calculated assuming a primary circuit inlet/outlet temperature of 80/70°C and a DHW inlet temperature of 12°C.

(2) Time needed to increase the domestic water inlet temperature, 12°C, to the storage temperature of 60°C.

(3) Quantity of domestic hot water available at a delivery temperature of 45°C, continuously or in the first 10 minutes.

(1) Heat exchanger output calculated assuming a primary circuit inlet/outlet temperature of 80/70°C and a DHW inlet temperature of 12°C.

(2) Time needed to increase the domestic water inlet temperature, 12°C, to the storage temperature of 60°C.

(3) Quantity of domestic hot water available at a delivery temperature of 45°C, continuously or in the first 10 minutes.

TABELLA SCAMBIATORI HEAT EXCHANGER TABLE

lt	200		300		500		800		1000		1500		2000		3000		4000		5000	
Di serie Standard (m ²)	Sc1	Sc2	Sc1	Sc2	Sc1	Sc2	Sc1	Sc2	Sc1	Sc2	Sc1	Sc2	Sc1	Sc2	Sc1	Sc2	Sc1	Sc2	Sc1	Sc2
	1	0.75	2	0.75	3	1	4	1	5	1.5	4	3	4	4	6	6	8	8	10	10
Optional (m ²)	0.75	1		1	1.5	0.75		0.75	4	2	5	1.5	5	5	4	4	4	4	4	4
					2					3	6	2	6	6	5	5	5	5	5	5
																	6	6	6	6
																			8	8

DATI SCAMBIATORI HEAT EXCHANGER DATA

m ²	0.75	1	1.5	2	3	4	5	6	8	10
KW	27	32	56	74	94	150	174	200	289	336
lt	4	5	8.5	10.5	14	19	22	24.8	33	40
mm	300	300	380	380	380	430	430	430	430	430

	Capacità accumulo (lt.) Storage tank capacity (lt.)
	Portata primario (l/h) Primary flow-rate (l/h)
	Portata ACS nei primi 10 min. DHW flow-rate in the first 10 min.

	Superficie di scambio (m ²) Heat exchanger surface (m ²)
	Tempo di messa a regime (min.) Time to reach temperature (min.)
	Contenuto acqua scambiatore (lt.) Heat exchanger capacity (lt.)

	Potenza di scambio (Kw) Heat exchanger power (Kw)
	Portata ACS (l/h) DHW flow-rate (l/h)
	Diametro flangia scambiatore Heat exchanger diameter flange

Uso: acqua calda sanitaria
Use: domestic hot water

Abbinabile con:
Combined with:





NS2XX

VITROFLEX

Isolamento flessibile spessore **100 mm**

Flexible insulation **100 mm** thick



 lt	Codice Code	 m ²	€	Classe Energetica ErP
200	NSIXX0200	1 + 0.75		C
300	NSIXX0300	2 + 0.75		C
500	NSIXX0500	3 + 1		C
800	NSIXX0800	4 + 1		C
1000	NSIXX1000	5 + 1.5		C
3000	NSXX3000	6 + 6		-
4000	NSXX4000	8 + 8		-
5000	NSXX5000	10 + 10		-

NS2XX

VITROFLEX

Isolamento flessibile spessore **130 mm**

Flexible insulation **130 mm** thick

 lt	Codice Code	 m ²	€	Classe Energetica ErP
1500	NSXX1500	4 + 3		C
2000	NSXX2000	4 + 4		C

Listino prezzi accessori e ricambi a pagina 116

Accessories and spare parts price list available at page 116



I prodotti della serie NS3 sono bollitori per la produzione e l'accumulo di acqua calda sanitaria. Gli scambiatori di calore sono a fascio tubiero estraibile, con tubi in acciaio inossidabile mandrinati su piastra in acciaio trattata VITROFLEX. La potenzialità di scambio è la maggiore nella loro categoria e li rendono il compromesso ideale fra potenza installata e volume d'acqua calda accumulato, sono ideali per impianti sanitari ove il prelievo di acqua calda raggiunge punte di richiesta elevate (centri sportivi, ospedali, piscine, impianti civili centralizzati...). Tutti gli scambiatori possono comunque essere collegati alla stessa fonte energetica ottenendo potenzialità di scambio eccezionali.



The NS3 series products are storage tanks for the production and storage of domestic hot water. The heat exchangers used are removable U-shaped tube bundles, made from stainless steel tubes expanded onto steel plates with VITROFLEX treatment. These stand out for their high heat exchange capacity with low pressure drop. These storage tanks represent the best compromise between installed power and volume of hot water stored, making them ideal for connection to domestic hot water systems where delivery of hot water has very high peaks (sports centres, hospitals, swimming pools, centralised residential systems, etc.). The "Heat exchangers/Models" table shows both the standard and compatible heat exchangers for each type of tank.

Tutti i serbatoi coibentati rispettano i requisiti richiesti dalle direttive 2009/125/CE e 2010/30/UE sull'efficienza energetica.

All the insulated tanks, comply with the directive 2009/125/CE and 2010/30UE about energy efficiency.

CARATTERISTICHE TECNICHE TECHNICAL FEATURES

Costruzione accumulo <i>Storage tank construction</i>	Acciaio al carbonio di elevata qualità <i>High quality carbon steel</i>
Trattamento interno <i>Inside treatment</i>	VITROFLEX idoneo per acqua uso alimentare secondo le direttive CE, D.M. 174/ GREZZO <i>VITROFLEX corrosion-proofing suitable for drinking water in accordance with EC directives / RAW</i>
Isolamento rimovibile <i>Removable insulation</i>	ECOFIRE, 1500÷2000 lt. spessore 130 mm <i>ECOFIRE, 1500÷2000 lt. 130 mm thick</i>
	ECOFIRE, 3000÷5000 lt. spessore 100 mm <i>ECOFIRE, 3000÷5000 lt. 100 mm thick</i>
Rivestimento esterno <i>Outside covering</i>	PVC accoppiato <i>Laminated PVC</i>
Accumulo <i>Storage tank</i>	Pmax 8 bar - Tmax 90°C
Scambiatore <i>Heat exchanger</i>	Pmax 12 bar - Tmax 110°C Estraibile acciaio inox <i>Removable stainless steel</i>
Accessori di serie <i>Standard accessories</i>	Anodo/i di magnesio con tester di controllo - Gruppo di scarico <i>Magnesium anode/anodes with tester - Drain assembly</i>
Garanzia <i>Warranty</i>	5 anni <i>5 years</i>

Uso: acqua calda sanitaria
Use: domestic hot water

Abbinabile con:
Combined with:



Esempio di impianto Example of a system

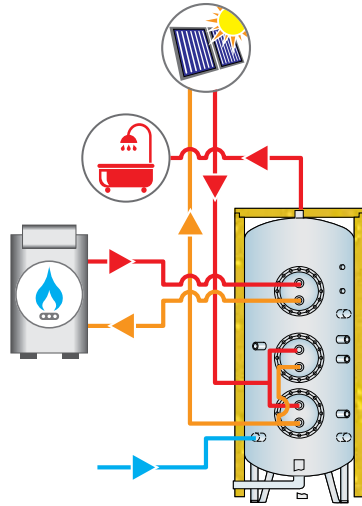

Disegno tecnico Technical drawing

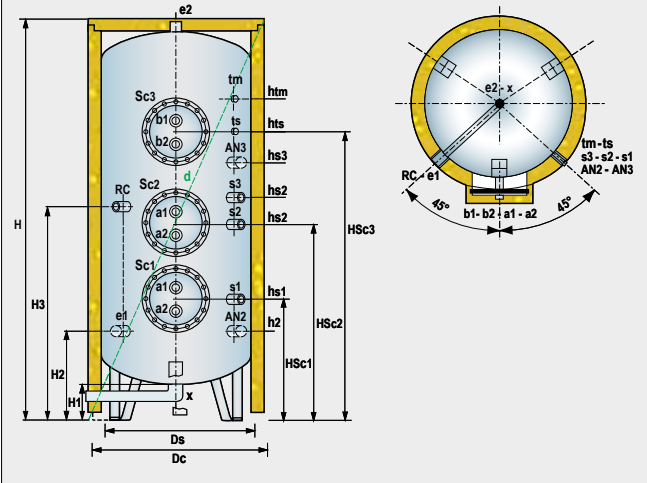

a1-a2	Entrata / uscita circuito primario Primary circuit inlet / outlet	AN2-AN3	Anodo Anode	tm	Attacco sonda temperatura Temperature probe fitting
b1-b2	Entrata / uscita circuito primario Primary circuit inlet / outlet	s1+s3	Attacco sonda ausiliaria Auxiliary probe fitting	RC	Ricircolo Recirculation
e1-e2	Entrata / uscita acqua sanitaria Domestic water inlet / outlet	ts	Attacco termostato Temperature probe fitting	X	Scarico Drain

	CONNESSIONI CONNECTIONS									
	a1-a2	b1-b2	e1	e2	AN2-AN3	s1+s3	ts	tm	RC	X
1500÷5000	G2"-F	G2"-F	G3"-F	G3"-F	G1" 1/4-F	G 1/2"-F	G 1/2"-F	G 1/2"-F	G1"-F	G3"-F

	DIMENSIONALE SIZES (mm)																	Peso Weight (Kg)
	Ds	Dc	H	H1	H2	H3	HSc1	HSc2	HSc3	Sonde Probes				Anodi Anodes		d		
		NS3 XX								hs1	hs2	hs3	hts	htm	h2		h3	
1500	950	1210	2530	185	485	1310	695	1150	1710	695	1150	1285	1710	1960	460	1510	2860	350
2000	1100	1360	2580	170	495	1320	705	1205	1720	705	1205	1340	1720	1970	470	1520	2975	410
3000	1250	1450	2795	150	520	1345	730	1230	1945	730	1230	1365	1945	2245	495	1745	3170	480
4000	1400	1600	2895	155	565	1385	770	1270	2035	770	1270	1405	2035	2285	535	1785	3330	695
5000	1600	1800	2930	130	580	1400	785	1285	2050	785	1285	1420	2050	2300	550	1800	3460	795



lt	PRESTAZIONI PERFORMANCE					
	m ²	KW ⁽¹⁾	l/h	min ⁽²⁾	l/h ⁽³⁾	l/10' ⁽³⁾
1500	4 + 3 + 1.5	300	25800	20	7818	1985
2000	4 + 4 + 2	374	32164	21	9747	2534
3000	6 + 6 + 3	494	42484	24	12874	3509
4000	8 + 8 + 4	728	62609	22	18972	4980
5000	10 + 10 + 5	846	72757	24	22048	5947

(1) Potenza termica dello scambiatore calcolata ipotizzando una temperatura di ingresso/uscita circuito primario di 80/70°C e di ingresso sanitario di 12°C

(2) Tempo necessario per innalzare la temperatura dell'acqua in ingresso sanitario, 12°C, alla temperatura di accumulo pari a 60°C.

(3) Quantità di acqua calda sanitaria disponibile alla temperatura di utilizzo di 45°C in continuo o nei primi 10 minuti.

(1) Heat exchanger output calculated assuming a primary circuit inlet/outlet temperature of 80/70°C and a DHW inlet temperature of 12°C.

(2) Time needed to increase the domestic water inlet temperature, 12°C, to the storage temperature of 60°C.

(3) Quantity of domestic hot water available at a delivery temperature of 45°C, continuously or in the first 10 minutes.

TABELLA SCAMBIATORI HEAT EXCHANGER TABLE															
lt	1500			2000			3000			4000			5000		
Di serie Standard (m ²)	Sc1	Sc2	Sc3	Sc1	Sc2	Sc3	Sc1	Sc2	Sc3	Sc1	Sc2	Sc3	Sc1	Sc2	Sc3
		4	3	1.5	4	4	2	6	6	3	8	8	4	10	10
Optional (m ²)	5	1.5	2	5	5	1.5	4	4	1.5	4	4	5	4	4	4
	6	2	3	6	6	3	5	5	2	5	5	6	5	5	6
										6	6	8	6	6	8
													8	8	10

DATI SCAMBIATORI HEAT EXCHANGER DATA											
m ²	0.75	1	1.5	2	3	4	5	6	8	10	
KW	27	32	56	74	94	150	174	200	289	336	
lt	4	5	8.5	10.5	14	19	22	24.8	33	40	
mm	300	300	380	380	380	430	430	430	430	430	

	Capacità accumulo (lt.) Storage tank capacity (lt.)
	Portata primario (l/h) Primary flow-rate (l/h)
	Portata ACS nei primi 10 min. DHW flow-rate in the first 10 min.

	Superficie di scambio (m ²) Heat exchanger surface (m ²)
	Tempo di messa a regime (min.) Time to reach temperature (min.)
	Contenuto acqua scambiatore (lt.) Heat exchanger capacity (lt.)

	Potenza di scambio (Kw) Heat exchanger power (Kw)
	Portata ACS (l/h) DHW flow-rate (l/h)
	Diametro flangia scambiatore Heat exchanger diameter flange

Uso: acqua calda sanitaria
Use: domestic hot water

Abbinabile con:
Combined with:



NS3XX

VITROFLEX

Isolamento flessibile spessore **100 mm**

Flexible insulation 100 mm thick

	Codice Code		€	Classe Energetica ErP
3000	NSIXX3000	6 + 6 + 3		-
4000	NSIXX4000	8 + 8 + 4		-
5000	NSIXX5000	10 + 10 + 5		-

NS3XX

VITROFLEX

Isolamento flessibile spessore **130 mm**

Flexible insulation 130 mm thick

	Codice Code		€	Classe Energetica ErP
1500	NSIXX1500	4 + 3 + 1.5		C
2000	NSIXX2000	4 + 4 + 2		C

Listino prezzi accessori e ricambi a pagina 116

Accessories and spare parts price list available at page 116



SECX

Bollitore con serpentino conico fisso ad ALTE PRESTAZIONI
Storage tank with HIGH PERFORMANCE fixed conical coil



SECX 150÷500

SECX 800÷1000



I prodotti della serie SECX sono bollitori per la produzione e l'accumulo di acqua calda sanitaria. Lo scambiatore di calore, inserito internamente al bollitore, presenta una particolare conformazione conica che assicura un'elevata resa termica grazie alla maggiore turbolenza, in questo modo si ottengono elevate produzioni di acqua calda sanitaria.



The SECX series products are storage tanks for the production and storage of domestic hot water. The fix coil heat exchanger has a special conical shape that ensures high heat output due to the greater turbulence created by the convective motion inside the storage cylinder, this means high domestic hot water production.

Tutti i serbatoi coibentati rispettano i requisiti richiesti dalle direttive 2009/125/CE e 2010/30/UE sull'efficienza energetica.
All the insulated tanks, comply with the directive 2009/125/CE and 2010/30UE about energy efficiency.

CARATTERISTICHE TECNICHE TECHNICAL FEATURES	
Costruzione accumulo <i>Storage tank construction</i>	Acciaio al carbonio di elevata qualità <i>High quality carbon steel</i>
Trattamento interno <i>Inside treatment</i>	Vetrificazione a due strati, idoneo per acqua uso alimentare secondo le direttive CE, D.M. 174 <i>Two layer vitrification suitable for drinking water in accordance with EC directives</i>
Isolamento <i>Insulated</i>	Poliuretano rigido iniettato, 150÷500 lt. spessore 50 mm <i>Injected rigid polyurethane, 150÷500 lt. 50 mm thick</i>
	ECOFIRE RIMOVIBILE, 800÷1000 lt. spessore 100 mm <i>REMOVABLE ECOFIRE, 800÷1000 lt. 100 mm thick</i>
Rivestimento esterno <i>Outside covering</i>	150÷500 lt: Lamierino zincato verniciato <i>150÷500 lt: Painted galvanised metal sheet</i>
	800÷1000 lt: PVC accoppiato <i>800÷1000 lt: Laminated PVC</i>
Accumulo <i>Storage tank</i>	Pmax 8 bar - Tmax 95°C
Scambiatore <i>Heat exchanger</i>	Pmax 12 bar -Tmax 110°C
Accessori di serie <i>Standard accessories</i>	Anodo di magnesio con tester di controllo <i>Magnesium anode with tester</i>
Garanzia <i>Warranty</i>	5 anni <i>5 years</i>

SECX VETRIFICAZIONE VITRIFICATION

	Codice Code	€	Classe Energetica ErP
150	SECX0150		C
200	SECX0200		C
300	SECX0300		C
500	SECX0500		C
800	SECX0800		C
1000	SECX1000		C

Listino prezzi accessori e ricambi a pagina 116

Accessories and spare parts price list available at page 116

Prodotti conformi alla direttiva 2014/68/UE PED (Art.4 Par.3)

Products complying with the directive 2014/68/UE PED (Art.4 Par.3)

Esempio di impianto Example of a system

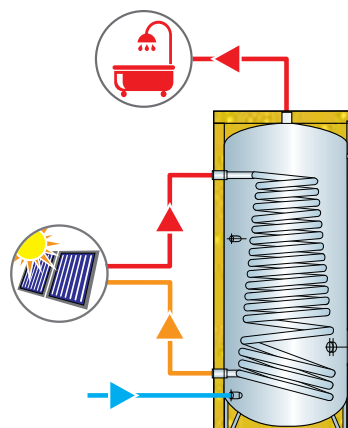

Usò: acqua calda sanitaria
Use: domestic hot water

Abbinabile con:
Combined with:





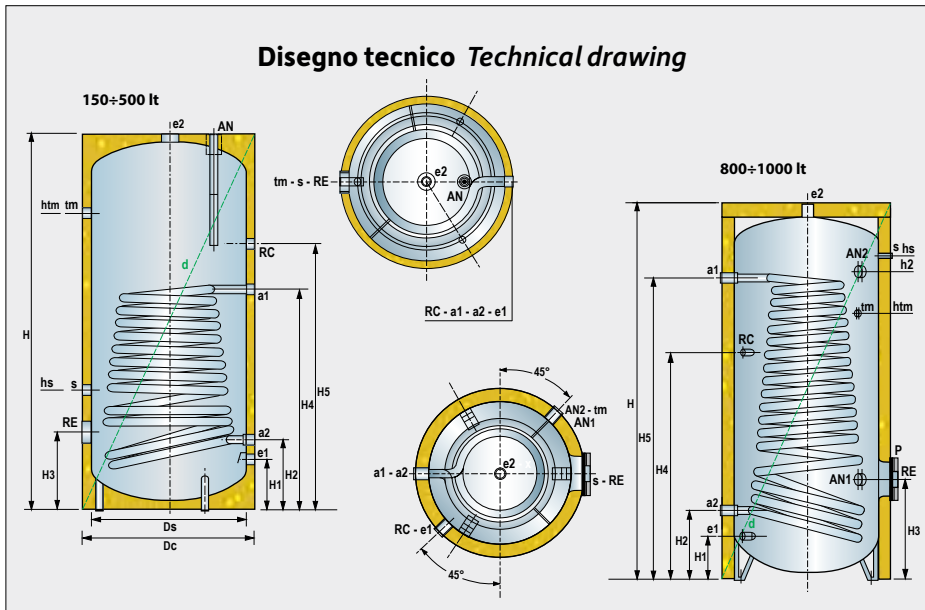



Disegno tecnico Technical drawing



a1-a2	Entrata / uscita circuito primario Primary circuit inlet / outlet
e1	Entrata acqua sanitaria Domestic water inlet
e2	Uscita acqua sanitaria Domestic water outlet
RE	Attacco resistenza elettrica Electric heater fitting
AN÷AN2	Anodo Anode
s	Attacco sonda ausiliaria Auxiliary probe fitting
tm	Attacco termometro thermometer fitting
RC	Ricircolo Recirculation
P	Attacco flangiato Fitting flanged

lt	CONNESSIONI CONNECTIONS								
	a1-a2	e1	e2	RE	AN÷AN2	s	tm	RC	P
150÷300	G3/4"-F	G1"-F	G1"1/4-F	G2"-F	G1"1/4-F	G1/2"-F	G1/2"-F	G1"-F	-
500	G1"-F	G1"-F	G1"1/4-F	G2"-F	G1"1/4-F	G1/2"-F	G1/2"-F	G1"-F	-
800-1000	G1"1/2-F	G1"1/4-F	G2"-F	G2"1/2-F	G1"1/4-F	G1/2"-F	G1/2"-F	G1"-F	øe203 - øi130

lt	DIMENSIONALE SIZES (mm)												Peso Weight (Kg)	
	Ds	Dc	H	H1	H2	H3	H4	H5	Sonde Probes		Anodi Anodes			d
									htm	hs	h1	h2		
150	450	550	1170	142	222	277	737	942	942	415	-	-	1295	65
200	450	550	1470	142	222	277	917	1177	1242	410	-	-	1635	80
300	550	650	1410	162	242	290	802	1147	1147	425	-	-	1616	95
500	650	750	1715	190	270	310	805	1185	1430	460	-	-	1936	150
800	790	990	1940	325	435	615	1175	1440	1255	1585	615	1525	2200	190
1000	790	990	2190	325	435	615	1175	1710	1505	1835	615	1775	2420	215

lt	PRESTAZIONI PERFORMANCE					
	 m ²	 KW ⁽¹⁾	 l/h	 min ⁽²⁾	 l/h ⁽³⁾	 l/10' ⁽³⁾
150	1.05	32.3	2778	19	842	208
200	1.25	38.8	3337	21	1011	259
300	1.60	46.8	4025	26	1220	340
500	2.30	68.2	5865	29	1777	523
800	3.40	93.8	8067	34	2445	771
1000	4.50	125.4	10785	32	3268	999

(1) Potenza termica dello scambiatore calcolata ipotizzando una temperatura di ingresso/uscita 55/50 °C in cond. 1 e 60/50°C in cond. 2, temperatura di accumulo 50°C e di ingresso sanitario di 10°C;
 (2) Quantità di acqua calda sanitaria disponibile alla temperatura di utilizzo di 45°C in continuo;
 (3) Tempo necessario per innalzare la temperatura dell'acqua in ingresso sanitario, 10°C, alla temperatura di accumulo pari a 50°C.
 (1) Heat exchanger output calculated assuming a primary circuit inlet/outlet temperature of 55/50°C at cond. 1 and 60/50°C at cond. 2, a storage temperature of 50°C and a DHW inlet temperature of 10°C;
 (2) Quantity of domestic hot water available at a delivery temperature of 45°C, continuously;
 (3) Time needed to increase the domestic water inlet temperature, 10°C, to the storage temperature of 50°C.



EVO 1 BASIC

Termoaccumulo per riscaldamento e sanitario istantaneo
Buffer tank for heating system and sanitary



EVO1BASIC è un termoaccumulo che, raccoglie energia sul primario e allo stesso tempo produce acqua calda sanitaria mediante uno scambiatore corrugato INOX AISI 316L di grande superficie di scambio ed elevatissima lunghezza termica. Inoltre EVO1BASIC funge anche da volano termico per il circuito di riscaldamento.



EVO1BASIC is a buffer tank for heating system that, collect energy on the primary circuit and at the same time produces domestic hot water through a corrugated AISI 316L STAINLESS STEEL exchanger with large exchange surface and very high heating tube length. Furthermore EVO1BASIC operates also as thermal flywheel for the heating circuit.

Tutti i serbatoi coibentati rispettano i requisiti richiesti dalle direttive 2009/125/CE e 2010/30/UE sull'efficienza energetica.

All the insulated tanks, comply with the directive 2009/125/CE and 2010/30UE about energy efficiency.

CARATTERISTICHE TECNICHE TECHNICAL FEATURES

Costruzione accumulo Storage tank construction	Acciaio al carbonio di elevata qualità High quality carbon steel
Trattamento interno Inside treatment	Trattamento interno grezzo, trattamento esterno verniciato Internal treatment raw, painted exterior treatment
Isolamento Insulation	ECOFIRE RIMOVIBILE, 500÷2000 lt. spessore 100 mm ECOFIRE REMOVABLE, 500÷2000 lt. 100 mm thick
Rivestimento esterno Outside covering	PVC accoppiato Laminated PVC
Accumulo Storage tank	Pmax 3 bar - Tmax 99°C
Scambiatore corrugato Corrugated heat exchanger	Pmax 6 bar - Tmax 99°C Acciaio Inox AISI 316L Stainless steel AISI 316L
Garanzia Warranty	5 anni 5 years

EVO1BASIC

Isolamento flessibile spessore 100 mm
Flexible insulation 100 mm thick

	Codice Code	€	Classe Energética ErP
500	EVO1B0500		C
800	EVO1B0800		C
1000	EVO1B1000		C
1500	EVO1B1500		C

VANTAGGI APPLICATIVI

- EVO1BASIC è sia un bollitore per produzione di ACS che un volano termico dedicato al circuito di riscaldamento.
- La priorità sul circuito ACS è automatica per circuitazione e dunque non serve più inserire una valvola a 3 vie che dia priorità all' ACS.
- L'acqua sanitaria è a contatto soltanto con l'acciaio INOX AISI 316L dello scambiatore ed essendo poi prodotta istantaneamente, non ha significativi ristagni minimizzando la probabilità di contaminazione batterica (LEGIONELLA).

APPLICATION ADVANTAGES

- EVO1BASIC is a storage tank for production of DHW and also a thermal flywheel dedicated to the heating circuit.
- The priority over the DHW circuit is automatic due to circulation and therefore it is no longer necessary to insert the 3-way valve, which gives priority to DHW.
- The DHW is only in contact with the AISI 316L STAINLESS STEEL of the heat exchanger and, as it is produced instantaneously, there is no significant stagnation, thus minimising the probability of bacterial contamination (LEGIONELLA).

Prodotti conformi alla direttiva 2014/68/UE PED (Art.4 Par.3)

Products complying with the directive 2014/68/UE PED (Art.4 Par.3)

Esempio di impianto Example of a system

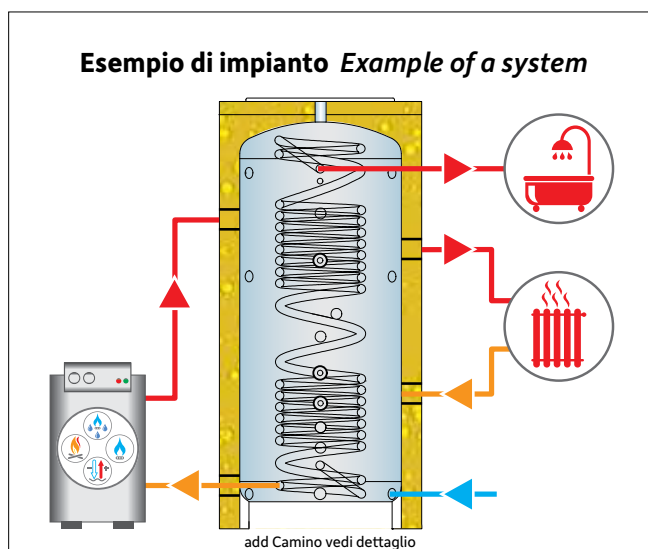

Uso: Acqua calda, sanitaria e riscaldamento
Use: Hot water, domestic and heating

Abbinabile con:
Combined with:



Disegno tecnico Technical drawing

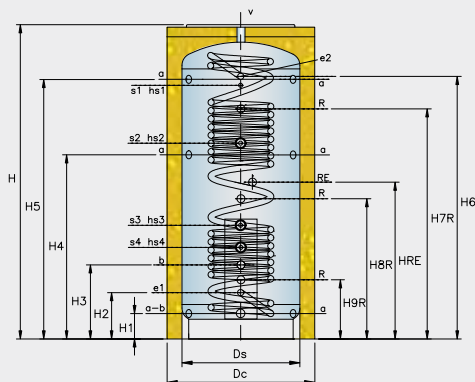

a/b	Ingresso/uscita primario e/o impianto riscaldamento Inlet/Outlet primary and/or heating system
e1-e2	ingresso/uscita ACS Inlet outlet DHW
s1+s4	Attacco sonda Probe connection
RE	Resistenza elettrica Electric heater
v	Manicotto fondo superiore Vent

lt	CONNESSIONI CONNECTIONS					
	a	b	S1+S4	e1+e2	RE	v
500+1500	G1"1/2-F	G1"1/2-F	G1/2" -F	G1" -F	G1"1/2-F	G1"1/2-F

lt	DIMENSIONALE SIZES (mm)													Sonde Probes				Peso Weight (Kg)
	Ds	Dc	H	H1	H2	H3	H4	H5	H6	H7R	H8R	H9R	HRE	hs1	hs2	hs3	hs4	
500	650	850	1750	150	250	430	1030	1450	1480	1360	775	325	900	1420	1140	650	540	115
800	790	990	1890	170	270	470	1050	1550	1590	1410	845	350	930	1520	1160	710	590	150
1000	790	990	2090	170	310	500	1210	1740	1760	1570	930	390	1050	1700	1320	770	620	170
1500	1000	1200	2220	235	345	690	1405	1820	1850	1720	1045	445	1280	1790	1520	920	800	270

PRESTAZIONI PERFORMANCE						
lt	m ²	mt	l/m 50°C	l/m 65°C	l/m 80°C	
500	5,5	30	23	38	53	
800	6,11	22	30	45	60	
1000	6,11	22	30	45	60	
1500	9,9	31	43	70	93	

Portata di acqua calda sanitaria calcolata ipotizzando una temperatura di ingresso/uscita sanitario di 12/45 °C, una temperatura media di accumulo di 50 °C (1) / 65 °C (2) / 80 °C (3) e primario in funzione.

Flow rate of domestic hot water calculated assuming a inlet/outlet temperature of 12/45 °C, a storage average temperature of 50 °C (1) / 65 °C (2) / 80 °C (3) and primary circuit working.



Capacità accumulo (lt.)
Storage tank capacity (lt.)



Superficie di scambio (m²) sc. corrugato
Exchange surface (m²) corrugated heat



Lunghezza totale scambiatore
Total lenght heat exchanger



Portata (l/m)
Flow-rate (l/m)



EVO 2 BASIC

Termoaccumulo per riscaldamento, solare termico e sanitario istantaneo

Buffer tank for heating, thermal solar and sanitary



EVO



EVO2BASIC è un termoaccumulo che, raccoglie energia sul primario e allo stesso tempo produce acqua calda sanitaria mediante uno scambiatore corrugato INOX AISI 316L di grande superficie di scambio ed elevata lunghezza termica. Dotato di un secondo scambiatore inferiore che permette l'utilizzo oltre alla caldaia tradizionale, di una fonte di energia alternativa quale quella solare e non solo. Inoltre EVO2BASIC funge anche da volano termico per il circuito di riscaldamento.



EVO2BASIC is a buffer tank for heating system that, collect energy on the primary circuit and at the same time produces domestic hot water through a corrugated AISI 316L STAINLESS STEEL exchanger with large exchange surface and very high heating tube length. Furthermore EVO2BASIC operates also as thermal flywheel for the heating circuit.

Tutti i serbatoi coibentati rispettano i requisiti richiesti dalle direttive 2009/125/CE e 2010/30/UE sull'efficienza energetica.

All the insulated tanks, comply with the directive 2009/125/CE and 2010/30UE about energy efficiency.

CARATTERISTICHE TECNICHE TECHNICAL FEATURES

Costruzione accumulo Storage tank construction	Acciaio al carbonio di elevata qualità High quality carbon steel
Trattamento interno Inside treatment	Trattamento interno grezzo, trattamento esterno verniciato Internal treatment raw, painted exterior treatment
Isolamento Insulation	ECOFIRE RIMOVIBILE, 500÷2000 lt. spessore 100 mm ECOFIRE REMOVABLE, 500÷2000 lt. 100 mm thick
Rivestimento esterno Outside covering	PVC accoppiato Laminated PVC
Accumulo Storage tank	Pmax 3 bar - Tmax 99°C
Scambiatore corrugato Corrugated heat exchanger	Pmax 6 bar - Tmax 99°C Acciaio Inox AISI 316L Stainless steel aisi 316L
Garanzia Warranty	5 anni 5 years

EVO2BASIC

Isolamento flessibile spessore 100 mm
Flexible insulation 100 mm thick

lt	Codice Code	€	Classe Energetica ErP
500	EVO2B0500		C
800	EVO2B0800		C
1000	EVO2B1000		C
1500	EVO2B1500		C

VANTAGGI APPLICATIVI

- EVO2BASIC è sia un bollitore per produzione di ACS che un volano termico dedicato al circuito di riscaldamento.
- La priorità sul circuito ACS è automatica per circuitazione e dunque non serve più inserire una valvola a 3 vie che dia priorità all' ACS.
- L'acqua sanitaria è a contatto soltanto con l'acciaio INOX AISI 316L dello scambiatore ed essendo poi prodotta istantaneamente, non ha significativi ristagni minimizzando la probabilità di contaminazione batterica (LEGIONELLA).

APPLICATION ADVANTAGES

- EVO2BASIC is a storage tank for production of DHW and also a thermal flywheel dedicated to the heating circuit.
- The priority over the DHW circuit is automatic due to circulation and therefore it is no longer necessary to insert the 3-way valve, which gives priority to DHW.
- The DHW is only in contact with the AISI 316L STAINLESS STEEL of the heat exchanger and, as it is produced instantaneously, there is no significant stagnation, thus minimising the probability of bacterial contamination (LEGIONELLA).

Prodotti conformi alla direttiva 2014/68/UE PED (Art.4 Par.3)

Products complying with the directive 2014/68/UE PED (Art.4 Par.3)

Esempio di impianto Example of a system

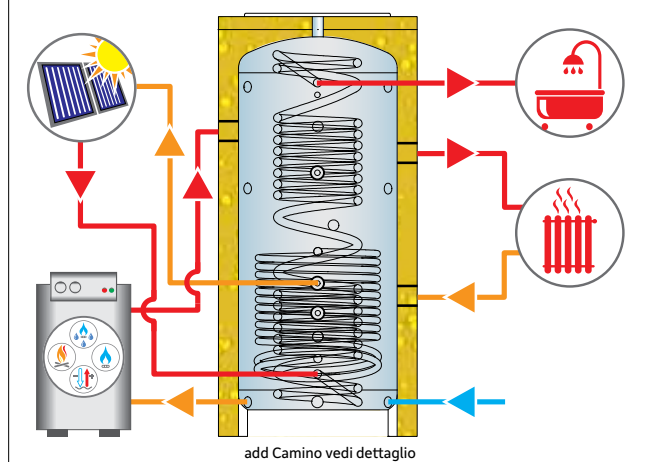

Uso: Acqua calda, sanitaria e riscaldamento
Use: Hot water, domestic and heating

Abbinabile con:
Combined with:



Disegno tecnico Technical drawing

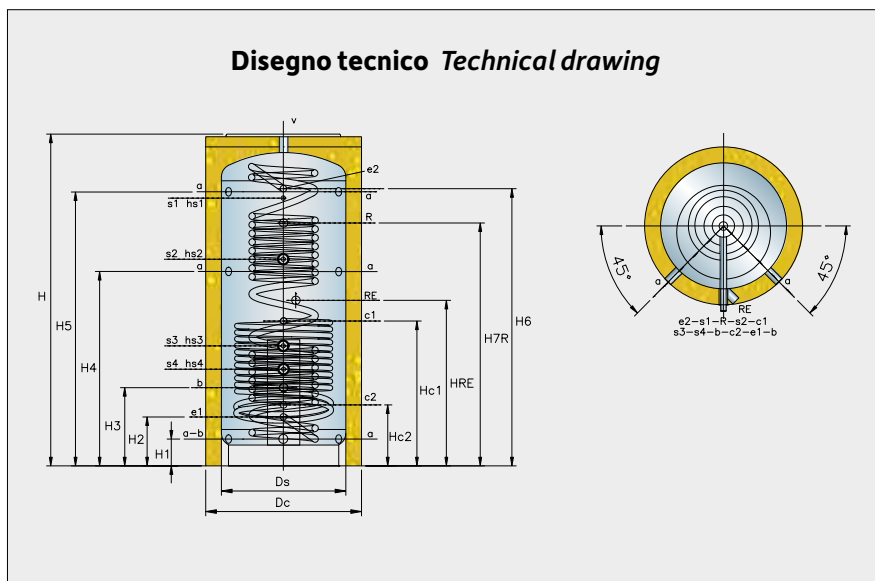

- a/b** Ingresso/uscita primario e/o impianto riscaldamento
Inlet/Outlet primary and/or heating system
- e1-e2** Ingresso/uscita ACS
Inlet/outlet DHW
- s1÷s4** Attacco sonda
Probe connection
- RE** Resistenza elettrica
Electric heater
- v** Manicotto fondo superiore
Vent
- c1-c2** Entrata/uscita scambiatore inferiore
Inlet/outlet lower heat exchanger

lt	CONNESSIONI CONNECTIONS						
	a	b	e1÷e2	S1÷S4	c1÷c2	RE	v
500÷1500	G1"1/2-F	G1"1/2-F	G1"-F	G1/2"-F	G1"-F	G1"1/2-F	G1"1/2-F

lt	DIMENSIONALE SIZES (mm)														Peso Weight (Kg)			
	Ds	Dc	H	H1	H2	H3	H4	H5	H6	H7R	Hc1	Hc2	HRE	Sonde Probes				
														hs1		hs2	hs3	hs4
500	650	850	1750	150	250	430	1030	1405	1480	1360	800	280	900	1420	1140	650	540	140
800	790	990	1890	170	270	470	1050	1550	1590	1410	820	310	930	1520	1160	710	590	190
1000	790	990	2090	170	310	500	1210	1740	1760	1570	880	310	1050	1700	1320	770	620	210
1500	1000	1200	2220	235	345	690	1405	1820	1850	1720	895	375	1280	1790	1520	920	800	330

PRESTAZIONI PERFORMANCE						
lt	m ²	mt	m ²	l/m ⁽¹⁾	l/m ⁽²⁾	l/m ⁽³⁾
				50°C	65°C	80°C
500	5,5	30	1,7	23	38	53
800	6,11	22	2,9	30	45	60
1000	6,11	22	3,0	30	45	60
1500	9,9	31	3,4	43	70	93

Portata di acqua calda sanitaria calcolata ipotizzando una temperatura di ingresso/uscita sanitario di 12/45 °C, una temperatura media di accumulo di 50 °C (1) / 65 °C (2) / 80 °C (3) e primario in funzione.

Flow rate of domestic hot water calculated assuming a inlet/outlet temperature of 12/45 °C, a storage average temperature of 50 °C (1) / 65 °C (2) / 80 °C (3) and primary circuit working.

lt	Capacità accumulo (lt.) Storage tank capacity (lt.)
l/m	Portata (l/m) Flow-rate (l/m)

m ²	Superficie di scambio (m ²) sc. corrugato Exchange surface (m ²) corrugated heat
----------------	---

mt	Lunghezza totale scambiatore Total lenght heat exchanger
----	---



EVO 3 BASIC

Termoaccumulo multienergie, solare termico e sanitario
Solar buffer tanks for heating system, thermal solar and sanitary



EVO3BASIC è un termoaccumulo che raccoglie energia sul primario e allo stesso tempo produce acqua calda sanitaria mediante uno scambiatore corrugato INOX AISI 316L di grande superficie di scambio ed elevata lunghezza termica. Dotato di due scambiatori, quello inferiore permette l'utilizzo di una fonte di energia alternativa quale quella solare, quello superiore permette l'utilizzo di una caldaia convenzionale o pompa di calore. Inoltre EVO3BASIC funge anche da volano termico per il circuito di riscaldamento.



EVO3BASIC is a buffer tank for heating system that, collect energy on the primary circuit and at the same time produces domestic hot water through a corrugated AISI 316L STAINLESS STEEL exchanger with large exchange surface and very high heat tube length. Equipped with two exchangers, the lower one allows the use of an alternative energy source as solar, the upper one allows the use of a conventional boiler or heat pump. EVO therefore operates as a storage tank but also a thermal flywheel for the heating circuit.

Tutti i serbatoi coibentati rispettano i requisiti richiesti dalle direttive 2009/125/CE e 2010/30/UE sull'efficienza energetica.

All the insulated tanks, comply with the directive 2009/125/CE and 2010/30UE about energy efficiency.

CARATTERISTICHE TECNICHE TECHNICAL FEATURES

Costruzione accumulo <i>Storage tank construction</i>	Acciaio al carbonio di elevata qualità <i>High quality carbon steel</i>
Trattamento interno <i>Inside treatment</i>	Trattamento interno grezzo, trattamento esterno verniciato <i>Internal treatment raw, painted exterior treatment</i>
Isolamento <i>Insulation</i>	ECOFIRE RIMOVIBILE, 500÷2000 lt. spessore 100 mm <i>ECOFIRE REMOVABLE, 500÷2000 lt. 100 mm thick</i>
Rivestimento esterno <i>Outside covering</i>	PVC accoppiato <i>Laminated PVC</i>
Accumulo <i>Storage tank</i>	Pmax 3 bar - Tmax 99°C
Scambiatore corrugato <i>Corrugated heat exchanger</i>	Pmax 6 bar - Tmax 99°C Acciaio Inox AISI 316L <i>Stainless steel aisi 316L</i>
Garanzia <i>Warranty</i>	5 anni <i>5 years</i>

EVO3BASIC

Isolamento flessibile spessore 100 mm
Flexible insulation 100 mm thick

	Codice Code	€	Classe Energica ErP
500	EVO3B0500		C
800	EVO3B0800		C
1000	EVO3B1000		C
1500	EVO3B1500		C

VANTAGGI APPLICATIVI

- EVO3BASIC è sia un bollitore per produzione di ACS che un volano termico dedicato al circuito di riscaldamento.
- La priorità sul circuito ACS è automatica per circuitazione e dunque non serve più inserire una valvola a 3 vie che dia priorità all' ACS.
- L'acqua sanitaria è a contatto soltanto con l'acciaio INOX AISI 316L dello scambiatore ed essendo poi prodotta istantaneamente, non ha significativi ristagni minimizzando la probabilità di contaminazione batterica (LEGIONELLA).

APPLICATION ADVANTAGES

- EVO3BASIC is a storage tank for production of DHW and also a thermal flywheel dedicated to the heating circuit.
- The priority over the DHW circuit is automatic due to circulation and therefore it is no longer necessary to insert the 3-way valve, which gives priority to DHW.
- The DHW is only in contact with the AISI 316L STAINLESS STEEL of the heat exchanger and, as it is produced instantaneously, there is no significant stagnation, thus minimising the probability of bacterial contamination (LEGIONELLA).

Prodotti conformi alla direttiva 2014/68/UE PED (Art.4 Par.3)

Products complying with the directive 2014/68/UE PED (Art.4 Par.3)

Esempio di impianto Example of a system

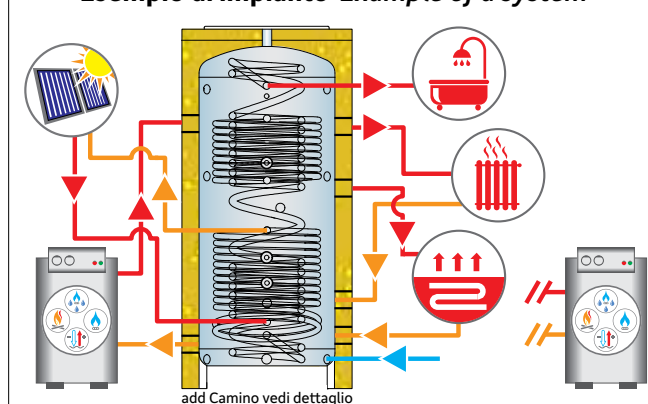



Disegno tecnico Technical drawing

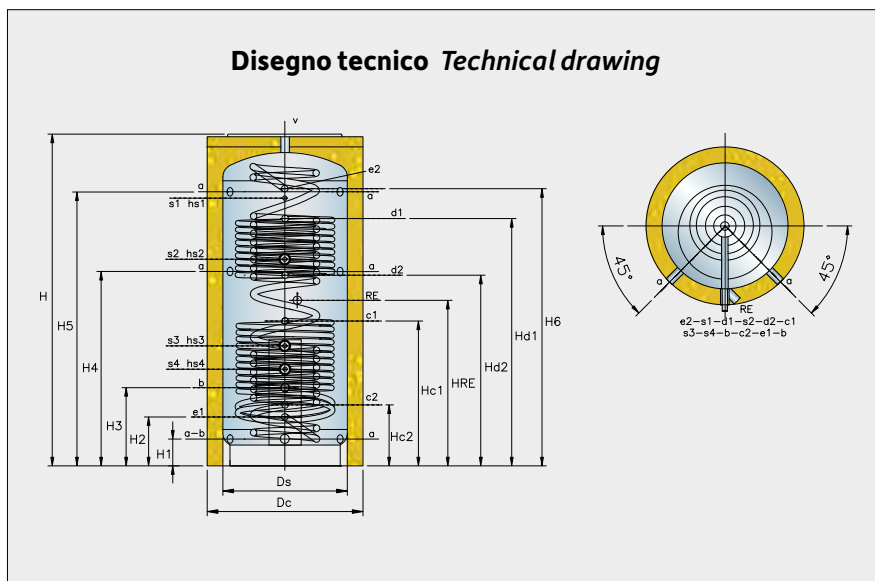

a/b	Ingresso/uscita primario e/o impianto riscaldamento Inlet/Outlet primary and/or heating system
e1-e2	Ingresso/uscita ACS Inlet/outlet DHW
s1÷s4	Attacco sonda Probe connection
RE	Resistenza elettrica Electric heater
v	Manicotto fondo superiore Vent
c1-c2	Entrata/uscita scambiatore inferiore inlet/outlet lower heat exchanger
d1-d2	Entrata/uscita scambiatore superiore inlet/outlet upper heat exchanger

lt	CONNESSIONI CONNECTIONS							
	a	b	e1÷e2	S1÷S4	c1÷c2	d1÷d2	RE	v
500÷1500	G1"1/2-F	G1"1/2-F	G1"-F	G1/2"-F	G1"-F	G1"-F	G1"1/2-F	G1"1/2-F

lt	DIMENSIONALE SIZES (mm)														Sonde Probes				Peso Weight (Kg)
	Ds	Dc	H	H1	H2	H3	H4	H5	H6	Hc1	Hc2	Hd1	Hd2	HRE	hs1	hs2	hs3	hs4	
500	650	850	1750	150	250	430	1030	1405	1480	800	280	1300	1020	900	1420	1140	650	540	165
800	790	990	1890	170	270	470	1050	1550	1590	820	310	1390	1070	930	1520	1160	710	590	210
1000	790	990	2090	170	310	500	1210	1740	1760	880	310	1520	1170	1050	1700	1320	770	620	230
1500	1000	1200	2220	235	345	690	1405	1820	1850	895	375	1635	1225	1280	1790	1520	920	800	255

PRESTAZIONI PERFORMANCE							
lt	m ²	mt	m ²	m ²	l/m ^{50°C} ⁽¹⁾	l/m ^{65°C} ⁽²⁾	l/m ^{80°C} ⁽³⁾
500	5,5	30	1,7	1,0	23	38	53
800	6,11	22	2,9	1,8	30	45	60
1000	6,11	22	3,0	2,0	30	45	60
1500	9,9	31	3,4	2,4	43	70	93

Portata di acqua calda sanitaria calcolata ipotizzando una temperatura di ingresso/uscita sanitario di 12/45 °C, una temperatura media di accumulo di 50 °C (1) / 65 °C (2) / 80 °C (3) e primario in funzione.

Flow rate of domestic hot water calculated assuming a inlet/outlet temperature of 12/45 °C, a storage average temperature of 50 °C (1) / 65 °C (2) / 80 °C (3) and primary circuit working.

lt	Capacità accumulo (lt.) Storage tank capacity (lt.)
l/m	Portata (l/m) Flow-rate (l/m)

m ²	Superficie di scambio (m ²) sc. corrugato Exchange surface (m ²) corrugated heat
----------------	---

mt	Lunghezza totale scambiatore Total lenght heat exchanger
----	---

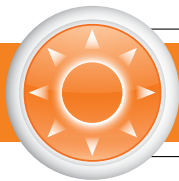

I prodotti della serie PS6X sono volani per l'accumulo e produzione di acqua calda tecnica. L'accumulo termico viene utilizzato per lo stoccaggio di acqua calda tecnica per riscaldamento quando si desidera un aumento dell'inerzia termica dell'impianto.



PS6X series products are buffer tanks for the storage and production of hot water for service uses. The storage tank is used for storing hot water in central heating systems. It is used in all cases where there is the need to increase the thermal inertia of the system.

Tutti i serbatoi coibentati rispettano i requisiti richiesti dalle direttive 2009/125/CE e 2010/30/UE sull'efficienza energetica.

All the insulated tanks, comply with the directive 2009/125/CE and 2010/30/UE about energy efficiency.

CARATTERISTICHE TECNICHE TECHNICAL FEATURES

Costruzione accumulo <i>Storage tank construction</i>	Acciaio al carbonio di elevata qualità <i>High quality carbon steel</i>
Trattamento interno <i>Inside treatment</i>	Trattamento interno grezzo, trattamento esterno grezzi <i>Internal treatment raw, external raw</i>
Isolamento rimovibile <i>Removable insulation</i>	ECOFIRE, 300÷1000 lt. spessore 100 mm <i>ECOFIRE, 300÷1000 lt. 100 mm thick</i>
	ECOFIRE, 1500÷2000 lt. spessore 130 mm <i>ECOFIRE, 1500÷2000 lt. 130 mm thick</i>
	ECOFIRE, 3000÷5000 lt. spessore 100 mm <i>ECOFIRE, 3000÷5000 lt. 100 mm thick</i>
Rivestimento esterno <i>Outside covering</i>	PVC accoppiato <i>Laminated PVC</i>
Accumulo <i>Storage tank</i>	Pmax 6 bar - Tmax 99°C
Garanzia <i>Warranty</i>	5 anni <i>5 years</i>

Esempio di impianto Example of a system

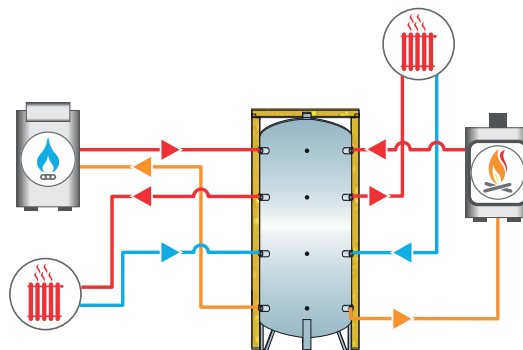

Disegno tecnico *Technical drawing*

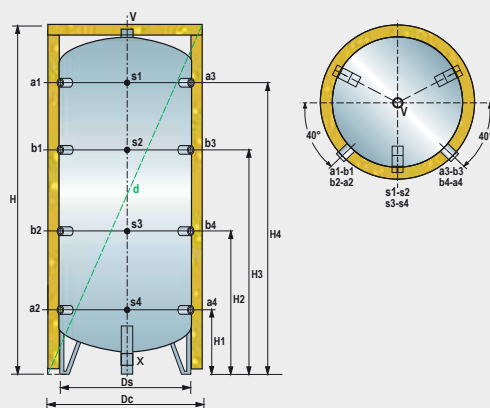

a1-a3	Mandata primario <i>Boiler inlet</i>
a2-a4	Ritorno primario <i>Boiler return</i>
b1-b3	Mandata riscaldamento <i>Central heating inlet</i>
b2-b4	Ritorno riscaldamento <i>Central heating return</i>
s1÷s4	Attacco sonda <i>Probe fitting</i>
x	Manicotto fondo <i>Bottom pipe connector</i>
v	Manicotto fondo superiore <i>Top pipe connector</i>

lt	CONNESSIONI CONNECTIONS						
	a1-a3	a2-a4	b1-b3	b2-b4	s1÷s4	v	x>2000
300÷1000	G1"1/2-F	G1"1/2-F	G1"1/2-F	G1"1/2-F	G1/2-F	G1"1/2-F	-
1500÷2000	G1"1/2-F	G1"1/2-F	G1"1/2-F	G1"1/2-F	G1/2-F	G3"-F	G1"1/4-F
3000÷5000	G2"-F	G2"-F	G2"-F	G2"-F	G1/2-F	G3"-F	G1"1/4-F

lt	DIMENSIONALE SIZES (mm)								Peso Weight (Kg)
	Ds	Dc	H	H1	H2	H3	H4	d	
300	550	750	1580	255	545	835	1125	1770	55
500	650	850	1895	280	655	1030	1405	2095	84
800	790	990	1940	320	695	1070	1145	2200	106
1000	790	990	2190	320	780	1240	1700	2420	125
1500	950	1210	2530	350	910	1470	2030	2860	215
2000	110	1360	2580	360	920	1480	2040	2975	260
3000	1250	1350	2795	520	1135	1750	2365	3170	303
4000	1400	1600	2895	560	1175	1790	2405	3330	477
5000	1600	1800	2930	575	1190	1805	2420	3460	560

PS6X

Isolamento flessibile spessore **100 mm**
Flexible insulation 100 mm thick

lt	Codice Code	€	Classe Energetica ErP
300	PS6X0300		C
500	PS6X0500		C
800	PS6X0800		C
1000	PS6X01000		C
3000	PS6X01500		-
4000	PS6X02000		-
5000	PS6X05000		-

PS6X

Isolamento flessibile spessore **130 mm**
Flexible insulation 130 mm thick

lt	Codice Code	€	Classe Energetica ErP
1500	PS6X01500		C
2000	PS6X02000		C

Listino prezzi accessori e ricambi a pagina 116
Accessories and spare parts price list available at page 116

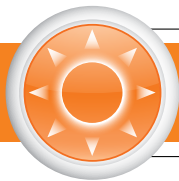

I prodotti della serie PB sono volani per l'accumulo e produzione di acqua calda tecnica. L'accumulo termico viene utilizzato per lo stoccaggio di acqua calda tecnica per riscaldamento quando si desidera un aumento dell'inerzia termica dell'impianto.



PB series products are buffer tanks for the storage and production of hot water for service uses. The storage tank is used for storing hot water in central heating systems. It is used in all cases where there is the need to increase the thermal inertia of the system.

Tutti i serbatoi coibentati rispettano i requisiti richiesti dalle direttive 2009/125/CE e 2010/30/UE sull'efficienza energetica.

All the insulated tanks, comply with the directive 2009/125/CE and 2010/30UE about energy efficiency.

CARATTERISTICHE TECNICHE TECHNICAL FEATURES

Costruzione accumulo <i>Storage tank construction</i>	Acciaio al carbonio di elevata qualità <i>High quality carbon steel</i>
Trattamento interno <i>Inside treatment</i>	Trattamento interno grezzo, trattamento esterno verniciato <i>Internal treatment raw, painted exterior treatment</i>
Isolamento rimovibile <i>Removable insulation</i>	ECOFIRE, 300÷2000 lt. spessore 100 mm <i>ECOFIRE, 300÷2000 lt. 100 mm thick</i>
Rivestimento esterno <i>Outside covering</i>	PVC accoppiato <i>Laminated PVC</i>
Accumulo <i>Storage tank</i>	Pmax 3 bar - Tmax 99°C
Garanzia <i>Warranty</i>	5 anni <i>5 years</i>

Esempio di impianto Example of a system

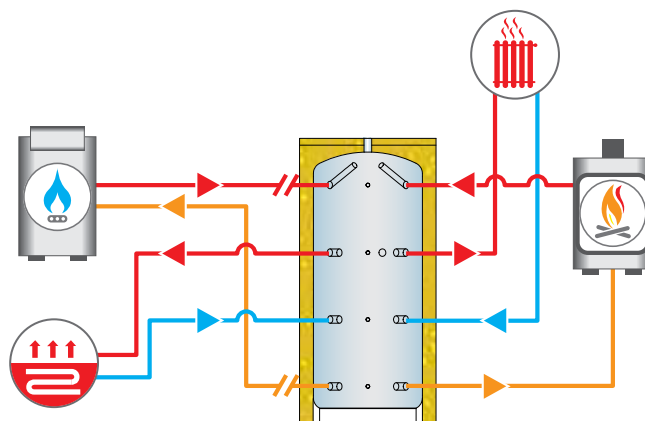



Disegno tecnico Technical drawing

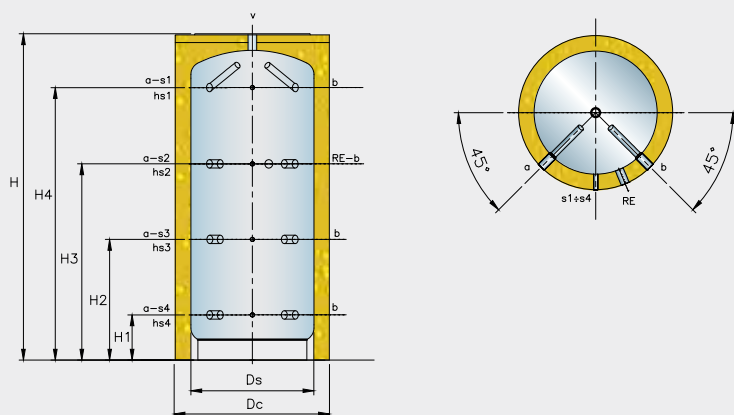

a-b	Utilizzo per primario Inlet/Outlet
s1+s4	Attacco sonda Probe connection
RE	Attacco per Resistenza Elettrica Electric heater connection
v	Manicotto fondo superiore Vent

It	CONNESSIONI CONNECTIONS				
	a	b	s1+s4	RE	v
300÷1000	G1"1/2-F	G1"1/2-F	G1/2" F	G1"1/2-F	G1"1/2-F
1500÷2000	G1"1/2-F	G1"1/2-F	G1/2" F	G1"1/2-F	G1"1/2-F

It	DIMENSIONALE SIZES (mm)											Peso Weight (Kg)
	Ds	Dc	H	H1	H2	H3	H4	Sonde Probes				
								hs1	hs2	hs3	hs4	
300	550	750	1460	240	550	860	1170	1170	860	550	240	62
500	650	850	1750	240	645	995	1450	1450	995	645	240	87
800	790	990	1890	290	710	1090	1750	1750	1090	710	290	115
1000	790	990	2090	290	775	1260	1750	1750	1260	775	290	130
1500	1000	1200	2290	340	835	1330	1820	1820	1327	835	340	210
2000	1200	1400	2180	390	850	1310	1770	1770	1310	850	390	250

PB

Isolamento flessibile spessore **100 mm**
Flexible insulation **100 mm thick**

It	Codice Code	€	Classe Energetica ErP
300	PB0300		C
500	PB0500		C
800	PB0800		C
1000	PB1000		C
1500	PB1500		C
2000	PB2000		C

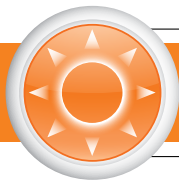

PB1R

Puffer solari per impianti di riscaldamento
Solar buffer tanks for central heating systems



 I prodotti della serie PB1R sono volani per l'accumulo e produzione di acqua calda tecnica. L'accumulo termico viene utilizzato per lo stoccaggio di acqua calda tecnica per riscaldamento quando si desidera un aumento dell'inerzia termica dell'impianto.

 *PB1R series products are buffer tanks for the storage and production of hot water for service uses. The storage tank is used for storing hot water in central heating systems. It is used in all cases where there is the need to increase the thermal inertia of the system.*

Tutti i serbatoi coibentati rispettano i requisiti richiesti dalle direttive 2009/125/CE e 2010/30/UE sull'efficienza energetica.
All the insulated tanks, comply with the directive 2009/125/CE and 2010/30UE about energy efficiency.

CARATTERISTICHE TECNICHE TECHNICAL FEATURES

Costruzione accumulo <i>Storage tank construction</i>	Acciaio al carbonio di elevata qualità <i>High quality carbon steel</i>
Trattamento interno <i>Inside treatment</i>	Trattamento interno grezzo, trattamento esterno verniciato <i>Internal treatment raw, painted exterior treatment</i>
Isolamento rimovibile <i>Removable insulation</i>	ECOFIRE, 300÷2000 lt. spessore 100 mm <i>ECOFIRE, 300÷2000 lt. 100 mm thick</i>
Rivestimento esterno <i>Outside covering</i>	PVC accoppiato <i>Laminated PVC</i>
Accumulo <i>Storage tank</i>	Pmax 3 bar - Tmax 99°C
Garanzia <i>Warranty</i>	5 anni <i>5 years</i>

PB1R

Isolamento flessibile spessore **100 mm**
Flexible insulation 100 mm thick

 lt	Codice <i>Code</i>	€	Classe Energetica ErP
500	PB1R0500		C
800	PB1R0800		C
1000	PB1R1000		C
1500	PB1R1500		C
2000	PB1R2000		C

Esempio di impianto *Example of a system*

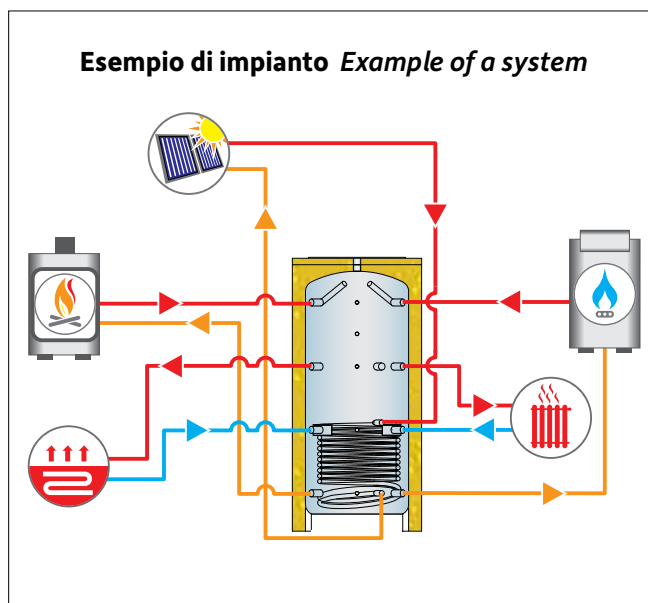

Uso: Riscaldamento
Use: Heating

Abbinabile con:
Combined with:



Disegno tecnico Technical drawing

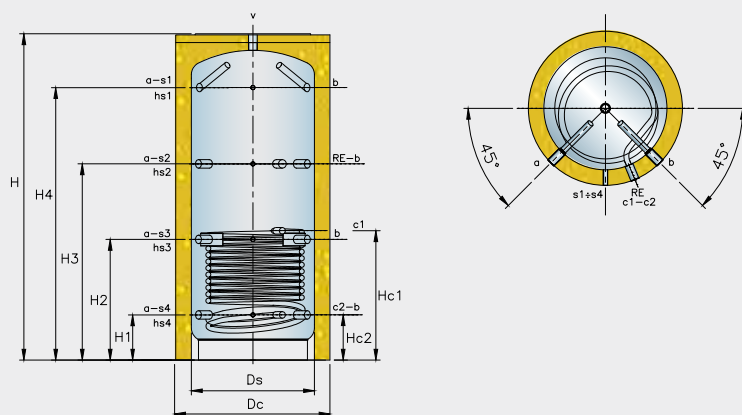

a-b	Utilizzo per primario e/o impianto riscaldamento Inlet/Outlet
s1÷s4	Attacco sonda Probe connection
RE	Attacco per Resistenza Elettrica Electric heater connection
v	Manicotto fondo superiore Vent
c1/c2	Entrata/Uscita scambiatore inferiore Inlet/Outlet heat exchanger

lt	CONNESSIONI CONNECTIONS					
	a	b	s1÷s4	c1÷c2	RE	v
500÷1000	G1"1/2-F	G1"1/2-F	G1/2"-F	G1"-F	G1"1/2-F	G1"1/2-F
1500÷2000	G1"1/2-F	G1"1/2-F	G1/2"-F	G1"-F	G1"1/2-F	G1"1/2-F

lt	DIMENSIONALE SIZES (mm)													Peso Weight (Kg)
	Ds	Dc	H	H1	H2	H3	H4	Hc1	Hc2	Sonde Probes				
										hs1	hs2	hs3	hs4	
500	650	850	1750	240	645	995	1450	690	240	1450	995	645	240	112
800	790	990	1890	290	710	1090	1750	785	290	1750	1090	710	290	148
1000	790	990	2090	290	775	1260	1750	830	290	1750	1260	775	290	170
1500	1000	1200	2290	340	835	1330	1820	940	340	1820	1327	835	340	260
2000	1200	1400	2180	390	850	1310	1770	1160	390	1770	1310	850	390	325

PRESTAZIONI PERFORMANCE			
lt	m ²	KW	l/h
500	1.9	18	1548
800	2.4	21	1840
1000	3.1	27	2322
1500	3.5	39	3354
2000	4.9	41	3526

Condizioni di funzionamento:

Cond. 1. Potenza termica dello scambiatore calcolata ipotizzando una temperatura di ingresso/uscita circuito primario di 75/65°C, di ingresso secondario 40°C e accumulo/uscita secondario 50°C.

Operating conditions:

Cond. 1. Heat exchanger output calculated assuming a primary circuit inlet/outlet temperature of 75/65°C, secondary inlet 40°C and asecondary storage inlet/outlet temperature of 50°C.

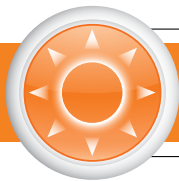

PB2R

Puffer multienergie per impianti di riscaldamento
Solar buffer tanks for central heating systems



I Prodotti della serie PB2R sono volani per l'accumulo e produzione di acqua calda tecnica, dotati di due serpentini fissi, uno dedicato al solare termico e l'altro per integrazione con generazione di calore. L'accumulo termico viene utilizzato per lo stoccaggio di acqua calda tecnica per il riscaldamento quanto si desidera un aumento dell'inerzia termica dell'impianto.



PB2R series products are puffer tanks for the storage and production of hot water for service use, with two fixed coils, one dedicated for the heating solar system and the second for integration with a heating generator. The storage tank is used for storing hot water in central heating systems, where is needed to increase the thermal inertia of the system.

Tutti i serbatoi coibentati rispettano i requisiti richiesti dalle direttive 2009/125/CE e 2010/30/UE sull'efficienza energetica.
All the insulated tanks, comply with the directive 2009/125/CE and 2010/30UE about energy efficiency.

CARATTERISTICHE TECNICHE TECHNICAL FEATURES

Costruzione accumulo <i>Storage tank construction</i>	Acciaio al carbonio di elevata qualità <i>High quality carbon steel</i>
Trattamento interno <i>Inside treatment</i>	Trattamento interno grezzo, trattamento esterno verniciato <i>Internal treatment raw, painted exterior treatment</i>
Isolamento rimovibile <i>Removable insulation</i>	ECOFIRE, 500÷2000 lt. spessore 100 mm <i>ECOFIRE, 500÷2000 lt. 100 mm thick</i>
Rivestimento esterno <i>Outside covering</i>	PVC accoppiato <i>Laminated PVC</i>
Accumulo <i>Storage tank</i>	Pmax 3 bar - Tmax 99°C
Scambiatore solare Scambiatore primario <i>Solar heat exchanger</i> <i>Primary heat exchanger</i>	Pmax 12 bar - Tmax 110°C
Garanzia <i>Warranty</i>	5 anni <i>5 years</i>

PB2R

Isolamento flessibile spessore 100 mm
Flexible insulation 100 mm thick

	Codice Code	€	Classe Energetica ErP
500	PB2R0500		C
800	PB2R0800		C
1000	PB2R1000		C
1500	PB2R1500		C
2000	PB2R2000		C

Esempio di impianto Example of a system

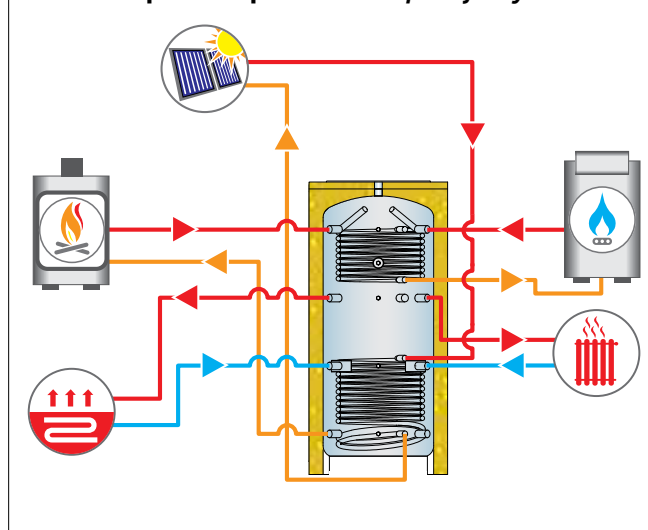

Uso: Riscaldamento
Use: Heating

Abbinabile con:
Combined with:



Disegno tecnico Technical drawing

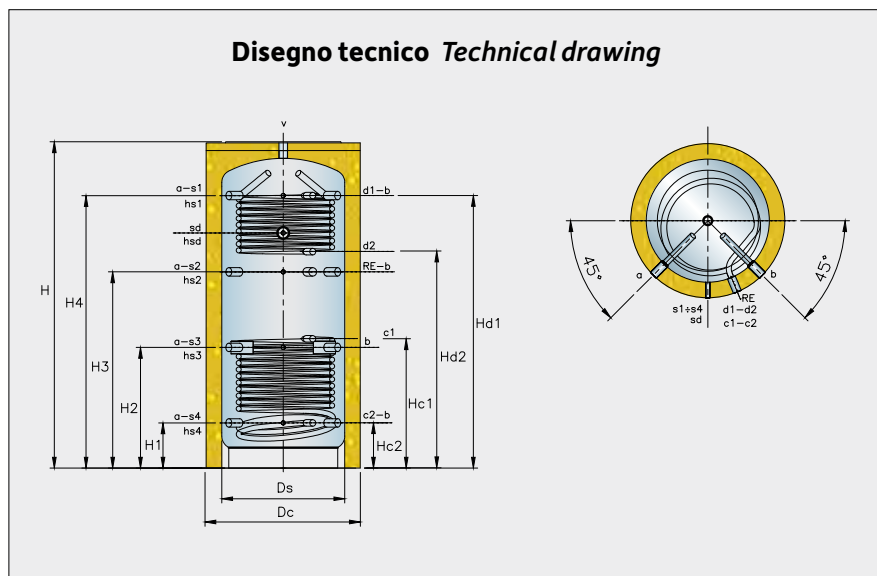

a-b	Utilizzo per primario e/o impianto riscaldamento Inlet/Outlet
s1÷s4	Attacco sonda Probe connection
RE	Attacco per Resistenza Elettrica Electric heater connection
v	Manicotto fondo superiore Vent
c1/c2	Entrata/Uscita scambiatore inferiore inlet/outlet lower heat exchanger
d1/d2	Entrata/Uscita scambiatore superiore inlet/outlet upper heat exchanger
sd	Attacco sonda Probe fitting

lt	CONNESSIONI CONNECTIONS							
	a	b	s1÷s4	c1-c2	d1-d2	sd	RE	v
500÷1000	G1"1/2-F	G1"1/2-F	G1/2"-F	G1"-F	G1"-F	G1/2"-F	G1"1/2-F	G1"1/2-F
1500÷2000	G1"1/2-F	G1"1/2-F	G1/2"-F	G1"-F	G1"-F	G1/2"-F	G1"1/2-F	G1"1/2-F

lt	DIMENSIONALE SIZES (mm)															Peso Weight (Kg)	
	Ds	Dc	H	H1	H2	H3	H4	Hc1	Hc2	Hd1	Hd2	Sonde Probes					
												hs1	hs2	hs3	hs4		hsd
500	650	850	1750	240	645	995	1450	690	240	1450	1120	1450	995	645	240	1230	120
800	790	990	1890	290	710	1090	1750	785	290	1550	1190	1750	1090	710	290	1310	168
1000	790	990	2090	290	775	1260	1750	830	290	1750	1390	1750	1260	775	290	1510	195
1500	1000	1200	2290	340	835	1327	1820	940	340	1820	1505	1820	1327	835	340	1610	290
2000	1200	1400	2180	390	850	1310	1770	1160	390	1770	1505	1770	1310	850	390	1590	365

PRESTAZIONI PERFORMANCE						
lt	INFERIORE LOWER			SUPERIORE UPPER		
500	1.90	18	1548	1.1	11.3	972
800	2.40	21	1840	1.70	15.50	1333
1000	3.10	27	2322	1.70	15.50	1333
1500	3.50	39	3354	1.93	18.00	1548
2000	4.90	51	3526	2.00	19.00	1634

Condizioni di funzionamento:

Cond. 1. Potenza termica dello scambiatore calcolata ipotizzando una temperatura di ingresso/uscita circuito primario di 80/70°C, di ingresso secondario 40°C e accumulo/uscita secondario 50°C.

Operating conditions:

Cond. 1. Heat exchanger output calculated assuming a primary circuit inlet/outlet temperature of 80/70°C, secondary inlet 40°C and a secondary storage inlet/outlet temperature of 50°C.



I prodotti della serie EVP sono bollitori per la produzione e l'accumulo di acqua calda sanitaria. Gli scambiatori di calore sono a fascio tubiero estraibile, con tubi in acciaio inossidabile mandrinati su piastra in acciaio trattata VITROFLEX. Una grande potenzialità di scambio unita a perdite di carico trascurabili li rendono il compromesso ideale fra potenza installata e volume d'acqua calda accumulato, sono ideali per impianti sanitari ove il prelievo di acqua calda raggiunge punte di richiesta elevate (centri sportivi, ospedali, piscine, impianti civili centralizzati,...).



The EVP series products are storage tanks for the production and storage of domestic hot water. The heat exchangers used are removable U-shaped tube bundles, made by stainless steel tubes expanded onto steel plates with VITROFLEX treatment. These storage tanks, with high heat exchange capacity and low pressure drop, represents the best compromise between installed power and volume of hot water stored, making them ideal for connection to domestic hot water systems where delivery of hot water has very high peaks (sports centres, hospitals, swimming pools, centralised residential systems,...).

Tutti i serbatoi coibentati rispettano i requisiti richiesti dalle direttive 2009/125/CE e 2010/30/UE sull'efficienza energetica.

All the insulated tanks, comply with the directive 2009/125/CE and 2010/30UE about energy efficiency.

CARATTERISTICHE TECNICHE TECHNICAL FEATURES

Costruzione accumulo <i>Storage tank construction</i>	Acciaio al carbonio di elevata qualità <i>High quality carbon steel</i>
Trattamento interno <i>Inside treatment</i>	VITROFLEX doneo per acqua uso alimentare secondo le direttive CE, D.M. 174/ GREZZO <i>VITROFLEX corrosion-proofing suitable for drinking water in accordance with EC directives / RAW</i>
Isolamento Rimovibile <i>Removable Insulation</i>	ECOFIRE, 300÷1000 lt. spessore 100 mm <i>ECOFIRE, 300÷1000 lt. 100 mm thick</i>
	ECOFIRE, 1500÷2000 lt. spessore 130 mm <i>ECOFIRE, 1500÷2000 lt. 130 mm thick</i>
	ECOFIRE, 2500÷5000 lt. spessore 100 mm <i>ECOFIRE, 2500÷5000 lt. 100 mm thick</i>
Rivestimento esterno <i>Outside covering</i>	PVC accoppiato <i>Laminated PVC</i>
Accumulo <i>Storage tank</i>	Pmax 8 bar - Tmax 90°C
Scambiatore <i>Heat exchanger</i>	Pmax 12 bar - Tmax 110°C Estraibile acciaio inox <i>Removable stainless steel</i>
Accessori di serie <i>Standard accessories</i>	Anodo/i di magnesio con tester di controllo <i>Magnesium anode/anodes with tester</i>
Garanzia <i>Warranty</i>	3 anni <i>3 years</i>

È disponibile il modello EVP RIBASSATO per installazioni in ambienti con altezza massima utilizzabile di 2.510 mm (vedi pag. 58)
The EVP LOWERED VERSION can be used for installation in rooms where the maximum height available is 2.510 mm (see pag. 58)

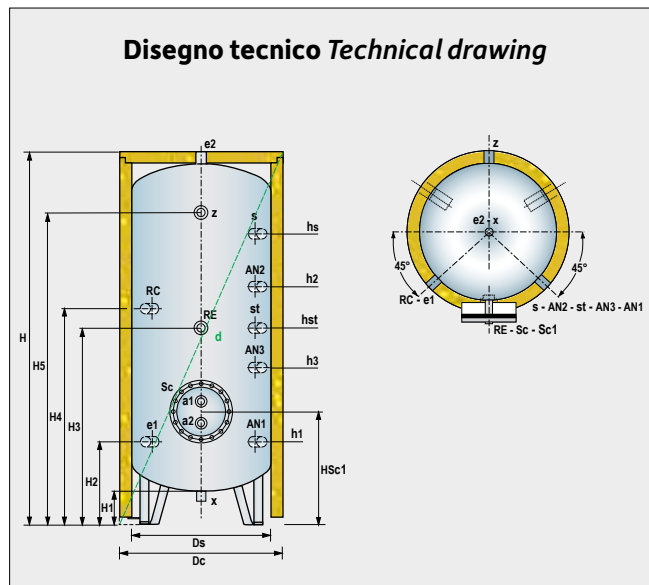
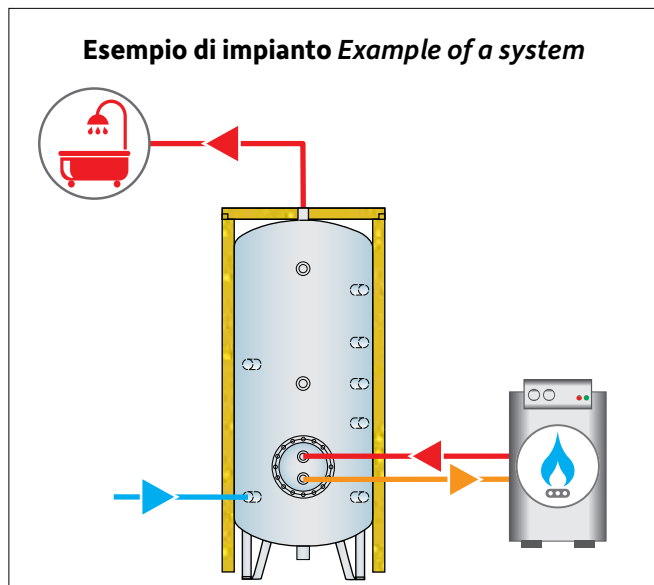

a1	Entrata circuito primario Primary circuit inlet
a2	Uscita circuito primario Primary circuit inlet
e1	Entrata acqua sanitaria Domestic water inlet
e2	Uscita acqua sanitaria Domestic water outlet

AN3	Anodo 300÷800 lt Anode 300÷800 lt
AN1-AN2	Anodi 1000÷5000 lt Anodes 1000÷5000 lt
RE	Attacco resistenza elettrica Electric heater fitting
Z	Attacco ausiliario 1500÷5000 Auxiliary fitting 1500÷5000

s	Attacco sonda ausiliaria Auxiliary probe fitting
st	Attacco sonda temperatura Temperature probe fitting
RC	Ricircolo Recirculation
X	Scarico Drain

lt	CONNESSIONI CONNECTIONS										
	a1	a2	e1	e2	AN1÷AN3	RE	Z	s	st	RC	X
300÷500	G1"-F	G1"-F	G1"1/4-F	G1"1/2-F	G1"1/4-F	G2"-F	-	G1/2"-F	G1/2"-F	G1"-F	G1"1/4-F
800÷1000	G2"-F	G2"-F	G1"1/4-F	G1"1/2-F	G1"1/4-F	G2"-F	-	G1/2"-F	G1/2"-F	G1"-F	G1"1/4-F
1500÷5000	G2"-F	G2"-F	G3"-F	G3"-F	G1"1/4-F	G2"-F	G2"-F	G1/2"-F	G1/2"-F	G1"-F	G3"-F

lt	DIMENSIONALE SIZES (mm)															Peso Weight (Kg)
	Ds	Dc	H	H1	H2	H3	H4	H5	HSc1	Sonde Probes		Anodi Anodes			d	
		EVPXX								hst	hs	h1	h2	h3		
300	550	750	1580	165	390	830	930	-	480	830	1230	-	-	700	1770	75
500	650	850	1895	155	410	850	1050	-	500	850	1400	-	-	720	2095	105
800	790	990	1940	145	430	1070	1170	-	560	1070	1520	-	-	920	2200	140
1000	790	990	2190	145	430	1070	1170	-	610	1070	1670	420	1370	-	2420	160
1500	950	1210	2530	185	485	1110	1310	2135	670	1110	1960	460	1560	-	2860	255
2000	1100	1360	2580	170	495	1220	1520	2145	705	1220	1970	470	1570	-	2975	320
2500	1250	1450	2605	150	520	1245	1545	2170	730	1245	1995	495	1595	-	3000	335
3000	1250	1450	2795	150	520	1245	1695	2370	730	1245	2245	495	1745	-	3170	360
4000	1400	1600	2895	155	570	1285	1735	2410	770	1285	2285	535	1785	-	3330	545
5000	1600	1800	2930	130	585	1300	1750	2425	785	1300	2300	550	1800	-	3460	635



PRESTAZIONI PERFORMANCE

lt	m ²	KW ⁽¹⁾	l/h	min ⁽²⁾	l/h ⁽³⁾	l/10' ⁽³⁾
300	0.75	27	2322	45	704	254
500	1	32	2752	63	834	366
800	1.5	56	4816	57	1459	607
1000	2	74	6364	54	1929	776
1500	3	94	8084	64	2450	1090
2000	4	150	12900	54	3909	1561
2500	5	174	14964	58	4535	1892
3000	6	200	17200	60	5212	2232
4000	8	289	24854	56	7532	3073
5000	10	336	28896	60	8756	3732

(1) Potenza termica dello scambiatore calcolata ipotizzando una temperatura di ingresso/uscita circuito primario di 80/70°C e di ingresso sanitario di 12°C;

(2) Tempo necessario per innalzare la temperatura dell'acqua in ingresso sanitario, 12°C, alla temperatura di accumulo pari a 60°C;

(3) Quantità di acqua calda sanitaria disponibile alla temperatura di utilizzo di 45°C in continuo o nei primi 10 minuti.

(1) Heat exchanger output calculated assuming a primary circuit inlet/outlet temperature of 80/70°C and a DHW inlet temperature of 12°C;

(2) Time needed to increase the domestic water inlet temperature, 12°C, to the storage temperature of 60°C;

(3) Quantity of domestic hot water available at a delivery temperature of 45°C, continuously or in the first 10 minutes.

TABELLA SCAMBIATORI HEAT EXCHANGER TABLE

lt	300	500	800	1000	1500	2000	2500	3000	4000	5000
Di serie Standard (m ²)	Sc1	Sc1	Sc1	Sc1	Sc1	Sc1	Sc1	Sc1	Sc1	Sc1
	0.75	1	1.5	2	3	4	5	6	8	10
Optional (m ²)	1	0.75	2	1.5	1.5	5	4	4	4	4
			3	3	2	6	6	5	5	5
									6	6
										8

DATI SCAMBIATORI HEAT EXCHANGER DATA

m ²	0.75	1	1.5	2	3	4	5	6	8	10
KW	27	32	56	74	94	150	174	200	289	336
lt	4	5	8.5	10.5	14	19	22	24.8	33	40
mm	300	300	380	380	380	430	430	430	430	430

lt	Capacità accumulo (lt.) Storage tank capacity (lt.)
l/h	Portata primario (l/h) Primary flow-rate (l/h)
l/10'	Portata ACS nei primi 10 min. DHW flow-rate in the first 10 min.



m ²	Superficie di scambio (m ²) Heat exchanger surface (m ²)
min	Tempo di messa a regime (min.) Time to reach temperature (min.)
lt	Contenuto acqua scambiatore (lt.) Heat exchanger capacity (lt.)



KW	Potenza di scambio (Kw) Heat exchanger power (Kw)
l/h	Portata ACS (l/h) DHW flow-rate (l/h)
mm	Diametro flangia scambiatore Heat exchanger diameter flange

Uso: acqua calda sanitaria
Use: domestic hot water

Abbinabile con:
Combined with:



EVPXX VITROFLEX Isolamento flessibile spessore 100 mm <i>Flexible insulation 100 mm thick</i>				
	Codice Code		€	Classe Energetica ErP
300	EVPXX0300	0.75		C
500	EVPXX0500	1		C
800	EVPXX0800	1.5		C
1000	EVPXX1000	2		C
2500	EVPXX2500	5		-
3000	EVPXX3000	6		-
4000	EVPXX4000	8		-
5000	EVPXX5000	10		-

EVPXX VITROFLEX Isolamento flessibile spessore 130 mm <i>Flexible insulation 130 mm thick</i>				
	Codice Code		€	Classe Energetica ErP
1500	EVPXX1500	3		C
2000	EVPXX2000	4		C

Listino prezzi accessori e ricambi a pagina 116

Accessories and spare parts price list available at page 116



EVP LOW

Bollitore con scambiatore estraibile RIBASSATO
Storage tank with removable heat exchanger LOWERED VERSION



I prodotti della serie EVP LOW sono bollitori per la produzione e l'accumulo di acqua calda sanitaria adatti per installazioni in ambienti con altezza massima utilizzabile fino a 2500 mm.
 Disponibili per capacità a partire da 1500 lt.



*The EVP LOW series are storage tanks for the production and storage of domestic hot water, suitable for installation in rooms with a maximum available height of 2500 mm.
 Available with capacities starting from 1500 litres.*

Tutti i serbatoi coibentati rispettano i requisiti richiesti dalle direttive 2009/125/CE e 2010/30/UE sull'efficienza energetica.
All the insulated tanks, comply with the directive 2009/125/CE and 2010/30UE about energy efficiency.

CARATTERISTICHE TECNICHE TECHNICAL FEATURES

Costruzione accumulo <i>Storage tank construction</i>	Acciaio al carbonio di elevata qualità <i>High quality carbon steel</i>
Trattamento interno <i>Inside treatment</i>	VITROFLEX idoneo per acqua uso alimentare secondo le direttive CE, D.M. 174/ GREZZO <i>VITROFLEX corrosion-proofing suitable for drinking water in accordance with EC directives / RAW</i>
Isolamento Rimovibile <i>Removable Insulation</i>	ECOFIRE, 1500÷2000 lt. spessore 130 mm <i>ECOFIRE, 1500÷2000 lt. 130 mm thick</i>
	ECOFIRE, 2500÷5000 lt. spessore 100 mm <i>ECOFIRE, 2500÷5000 lt. 100 mm thick</i>
Rivestimento esterno <i>Outside covering</i>	PVC accoppiato <i>Laminated PVC</i>
Accumulo <i>Storage tank</i>	Pmax 8 bar - Tmax 90°C
Scambiatore <i>Heat exchanger</i>	Pmax 12 bar - Tmax 110°C Estraibile acciaio inox <i>Removable stainless steel</i>
Accessori di serie <i>Standard accessories</i>	Anodo/i di magnesio con tester di controllo <i>Magnesium anode/anodes with tester</i>
Garanzia <i>Warranty</i>	3 anni <i>3 years</i>

Uso: acqua calda sanitaria
Use: domestic hot water

Abbinabile con:
Combined with:



Esempio di impianto Example of a system

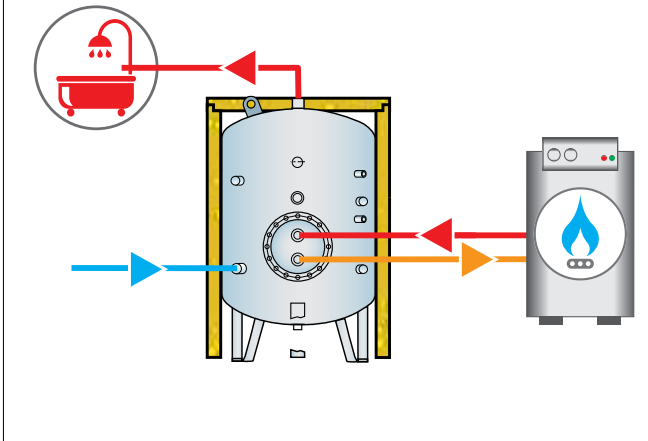

Disegno tecnico Technical drawing

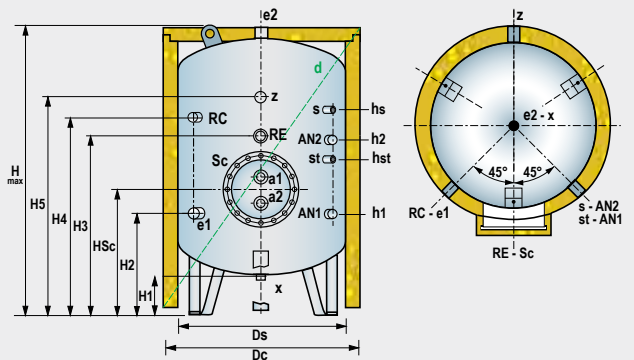

a1	Entrata circuito primario Primary circuit inlet
a2	Uscita circuito primario Primary circuit inlet
e1	Entrata acqua sanitaria Domestic water inlet
e2	Uscita acqua sanitaria Domestic water outlet

AN1-AN2	Anodi Anodes
RE	Attacco resistenza elettrica Electric heater fitting
Z	Attacco ausiliario Auxiliary fitting
s	Attacco sonda ausiliaria Auxiliary probe fitting

st	Attacco sonda temperatura Temperature probe fitting
RC	Ricircolo Recirculation
X	Scarico Drain

	CONNESSIONI CONNECTIONS										
	a1	a2	e1	e2	AN1÷AN3	RE	Z	s	st	RC	X
1500÷5000	G2"-F	G2"-F	G3"-F	G3"-F	G1"1/4-F	G2"-F	G2"-F	G1/2"-F	G1/2"-F	G1"-F	3"

	DIMENSIONALE SIZES (mm)															Peso Weight (Kg)
	Ds	Dc	Hmax	H1	H2	H3	H4	H5	HSc	Sonde Probes		Anodi Anodes		d		
		EVPXX LOW								hst	hs	h1	h2			
1500	1100	1360	2080	170	495	1120	1220	1570	705	1120	1570	470	1370	2545	3	255
2000	1250	1510	2080	150	520	1080	1395	1570	730	1080	1545	495	1345	2630	4	320
2500	1400	1600	2000	155	560	1120	1185	1410	770	985	1385	535	1285	2585	5	335
3000	1600	1800	2000	130	575	1085	1150	1400	785	1085	1400	550	1200	2715	6	360
3000 B	1400	1600	2300	155	570	1185	1385	1810	770	1185	1685	535	1485	2825	6	360
4000	1900	2100	2000	130	640	1200	1345	1390	850	1065	1380	615	1295	2925	8	454
4000 B	1600	1800	2500	130	585	1300	1250	1925	785	1300	1800	550	1500	3100	8	454
5000	1900	2100	2250	120	630	1190	1455	1655	840	1190	1605	605	1405	3100	10	635



PRESTAZIONI PERFORMANCE

		⁽¹⁾		⁽²⁾	⁽³⁾	⁽³⁾
1500	3	94	8084	64	2450	1090
2000	4	150	12900	54	3909	1561
2500	5	174	14964	58	4535	1892
3000	6	200	17200	60	5212	2232
4000	8	289	24854	56	7532	3073
5000	10	336	28896	60	8756	3732

(1) Potenza termica dello scambiatore calcolata ipotizzando una temperatura di ingresso/uscita circuito primario di 80/70°C e di ingresso sanitario di 12°C.

(2) Tempo necessario per innalzare la temperatura dell'acqua in ingresso sanitario, 12°C, alla temperatura di accumulo pari a 60°C.

(3) Quantità di acqua calda sanitaria disponibile alla temperatura di utilizzo di 45°C in continuo o nei primi 10 minuti.

(1) Heat exchanger output calculated assuming a primary circuit inlet/outlet temperature of 80/70°C and a DHW inlet temperature of 12°C.

(2) Time needed to increase the domestic water inlet temperature, 12°C, to the storage temperature of 60°C.

(3) Quantity of domestic hot water available at a delivery temperature of 45°C, continuously or in the first 10 minutes.

TABELLA SCAMBIATORI HEAT EXCHANGER TABLE

	1500	2000	2500	3000	4000	5000
Di serie Standard (m²)	Sc1	Sc1	Sc1	Sc1	Sc1	Sc1
	3	4	5	6	8	10
Optional (m²)	1.5	5	4	4	4	4
	2	6	6	5	5	5
					6	6
						8

DATI SCAMBIATORI HEAT EXCHANGER DATA

	1.5	2	3	4	5	6	8	10
	56	74	94	150	174	200	289	336
	8.5	10.5	14	19	22	24.8	33	40
	380	380	380	430	430	430	430	430

Capacità accumulo (lt.)
Storage tank capacity (lt.)

Portata primario (l/h)
Primary flow-rate (l/h)

Portata ACS nei primi 10 min.
DHW flow-rate in the first 10 min.

Superficie di scambio (m²)
Heat exchanger surface (m²)

Tempo di messa a regime (min.)
Time to reach temperature (min.)

Contenuto acqua scambiatore (lt.)
Heat exchanger capacity (lt.)

Potenza di scambio (Kw)
Heat exchanger power (Kw)

Portata ACS (l/h)
DHW flow-rate (l/h)

Diametro flangia scambiatore
Heat exchanger diameter flange

Uso: acqua calda sanitaria
Use: domestic hot water

Abbinabile con:
Combined with:





EVPXX LOW

VITROFLEX

Isolamento flessibile spessore **100 mm**

Flexible insulation **100 mm** thick

	Codice Code		€	Classe Energetica ErP
2500	EVPXX02500B	5		-
3000	EVPXX03000B	6		-
3000B	EVPXX03000BB	6		-
4000	EVPXX04000B	8		-
4000B	EVPXX04000BB	8		-
5000	EVPXX05000B	10		-

Listino prezzi accessori e ricambi a pagina 116



Accessories and spare parts price list available at page 116

EVPXX LOW

VITROFLEX

Isolamento flessibile spessore **130 mm**

Flexible insulation **130 mm** thick

	Codice Code		€	Classe Energetica ErP
1500	EVPXX01500B	3		C
2000	EVPXX02000B	4		C



116

Accumuli inerziali di acqua calda sanitaria
Domestic hot water storage tanks

I prodotti della serie 116 sono accumuli inerziali per acqua calda sanitaria. Ideali negli impianti ove il prelievo di acqua calda raggiunga punte di richiesta elevate e generalmente sono collegati a scambiatori di calore esterni, il più delle volte a piastre (piscine, centri sportivi, alberghi, campeggi).



The 116 series products are domestic hot water storage tanks. These are ideal in systems where the delivery of hot water has very high peaks and are generally connected to external heat exchangers, more commonly plate heat exchangers (swimming pools, sports centers, hotels, camping).

Tutti i serbatoi coibentati rispettano i requisiti richiesti dalle direttive 2009/125/CE e 2010/30/UE sull'efficienza energetica.

All the insulated tanks, comply with the directive 2009/125/CE and 2010/30UE about energy efficiency.

CARATTERISTICHE TECNICHE TECHNICAL FEATURES

Costruzione accumulo <i>Storage tank construction</i>	Acciaio al carbonio di elevata qualità <i>High quality carbon steel</i>
Trattamento interno <i>Inside treatment</i>	VITROFLEX idoneo per acqua uso alimentare secondo le direttive CE, D.M. 174/ GREZZO <i>VITROFLEX corrosion-proofing suitable for drinking water in accordance with EC directives / RAW</i>
Isolamento Rimovibile <i>Removable Insulation</i>	ECOFIRE, 300÷1000 lt. spessore 100 mm <i>ECOFIRE, 300÷1000 lt. 100 mm thick</i>
	ECOFIRE, 1500÷2000 lt. spessore 130 mm <i>ECOFIRE, 1500÷2000 lt. 130 mm thick</i>
	ECOFIRE, 3000÷5000 lt. spessore 100 mm <i>ECOFIRE, 3000÷5000 lt. 100 mm thick</i>
Rivestimento esterno <i>Outside covering</i>	PVC accoppiato <i>Laminated PVC</i>
Accumulo <i>Storage tank</i>	Pmax 8 bar - Tmax 90°C
Accessori di serie <i>Standard accessories</i>	Anodo/i di magnesio con tester di controllo <i>Magnesium anode/anodes with tester</i>
Garanzia <i>Warranty</i>	3 anni <i>3 years</i>

È disponibile il modello 116 RIBASSATO per installazioni in ambienti con altezza massima utilizzabile di 2.510 mm (vedi pag. 64)
The 116 LOWERED VERSION can be used for installation in rooms where the maximum height available is 2.510 mm (see pag. 64)

116PX
VITROFLEX

Isolamento flessibile spessore **100 mm**
Flexible insulation 100 mm thick

	Codice Code	€	Classe Energetica ErP
300	116PX0300		C
500	116PX0500		C
800	116PX0800		C
1000	116PX1000		C
3000	116PX3000		-
4000	116PX4000		-
5000	116PX5000		-

116PX
VITROFLEX

Isolamento flessibile spessore **130 mm**
Flexible insulation 130 mm thick

	Codice Code	€	Classe Energetica ErP
1500	116PX1500		C
2000	116PX2000		C

Listino prezzi accessori e ricambi a pagina 116

Accessories and spare parts price list available at page 116

Prodotti conformi alla direttiva 2014/68/UE PED (Art.4 Par.3)

Products complying with the directive 2014/68/UE PED (Art.4 Par.3)



Esempio di impianto Example of a system

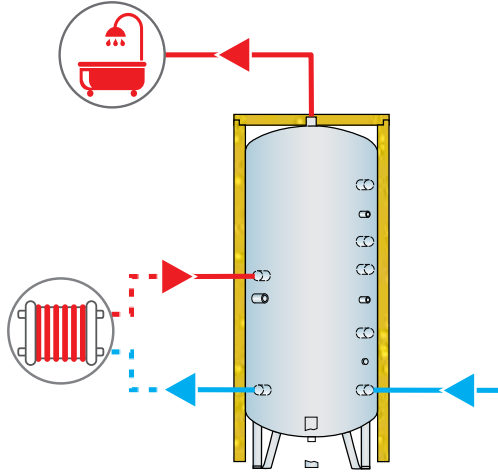

Disegno tecnico Technical drawing

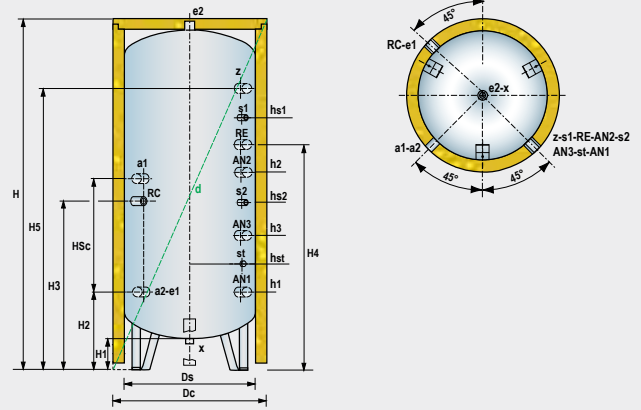

a1	Entrata circuito primario Primary circuit inlet
a2	Uscita circuito primario Primary circuit outlet
e1	Entrata acqua sanitaria Domestic water inlet
e2	Uscita acqua sanitaria Domestic water outlet

AN3	Anodo 300÷800 lt Anode 300÷800 lt
AN1-AN2	Anodi 1500÷5000 lt Anodes 1500÷5000 lt
RE/RE2	Attacco resistenza elettrica Electric heater fitting
s1-s2	Attacco sonda ausiliaria Auxiliary probe fitting

st	Attacco temperatura Temperature probe fitting
RC	Ricircolo Recirculation
X	Scarico Drain

lt	CONNESSIONI CONNECTIONS										
	a1	a2	e1	e2	AN1÷AN3	RE	Z	s1 - s2	st	RC	X
300÷1000	G1"1/4-F	G1"1/4-F	G1"1/4-F	G1"1/2-F	G1"1/4-F	G2"-F	-	G1/2"-F	G1/2"-F	G1"-F	G1"1/4-F
1500÷5000	G1"1/4-F	G1"1/4-F	G3"-F	G3"-F	G1"1/4-F	-	G2"-F	G1/2"-F	G1/2"-F	G1"-F	G3"-F

lt	DIMENSIONALE SIZES (mm)															Peso Weight (Kg)	
	Ds	Dc	H	H1	H2	H3	H4	H5	HSc	Sonde Probes			Anodi Anodes				d
										hst	hs1	hs2	h1	h2	h3		
300	550	750	1580	165	390	930	980	-	880	525	1280	-	-	-	700	1770	55
500	650	850	1895	155	410	1050	1190	-	940	540	1500	-	-	-	720	2095	84
800	790	990	1940	145	430	1170	1170	-		585	1520	-	-	-	920	2200	106
1000	790	990	2190	145	445	1170	1570	-		655	1720	-	420	1170	-	2420	125
1500	950	1210	2530	185	485	1310	-	2135		710	1960	1150	460	1510	-	2860	235
2000	1100	1360	2580	170	495	1320	-	2145		720	1970	1205	470	1520	-	2975	280
3000	1250	1450	2795	150	520	1345	-	2370		745	2245	1230	495	1745	-	3170	303
4000	1400	1600	2895	155	560	1385	-	2410		785	2285	1270	535	1785	-	3330	477
5000	1600	1800	2930	130	575	1400	-	2425		800	2300	1285	550	1800	-	3460	560



116 LOW

Accumuli ACS ribassati
DHW storage tanks lowered version



I prodotti della serie 116 LOW sono accumuli inerziali per acqua calda sanitaria adatti per installazioni in ambienti con altezza massima utilizzabile fino a 2500 mm.

Ideali negli impianti ove il prelievo di acqua calda raggiunga punte di richiesta elevate e generalmente sono collegati a scambiatori di calore esterni, il più delle volte a piastre (piscine, centri sportivi, alberghi, campeggi).

Disponibili per capacità a partire da 1500 lt.



The 116 LOW series products are domestic hot water storage tanks, suitable for installation in rooms with a maximum available height of 2500 mm.

These are ideal in systems where the delivery of hot water has very high peaks and are generally connected to external heat exchangers, more commonly plate heat exchangers (swimming pools, sports centers, hotels, camping).

Available with capacities starting from 1500 litres.

Tutti i serbatoi coibentati rispettano i requisiti richiesti dalle direttive 2009/125/CE e 2010/30/UE sull'efficienza energetica.

All the insulated tanks, comply with the directive 2009/125/CE and 2010/30UE about energy efficiency.

CARATTERISTICHE TECNICHE TECHNICAL FEATURES

Costruzione accumulo Storage tank construction	Acciaio al carbonio di elevata qualità High quality carbon steel
Trattamento interno Inside treatment	VITROFLEX idoneo per acqua uso alimentare secondo le direttive CE, D.M. 174/ GREZZO VITROFLEX corrosion-proofing suitable for drinking water in accordance with EC directives / RAW
Isolamento Rimovibile Removable Insulation	ECOFIRE, 1500÷2000 lt. spessore 130 mm ECOFIRE, 1500÷2000 lt. 130 mm thick
	ECOFIRE, 2500÷5000 lt. spessore 100 mm ECOFIRE, 2500÷5000 lt. 100 mm thick
Rivestimento esterno Outside covering	PVC accoppiato Laminated PVC
Accumulo Storage tank	Pmax 8 bar - Tmax 90°C
Accessori di serie Standard accessories	Anodo/i di magnesio con tester di controllo Magnesium anode/anodes with tester
Garanzia Warranty	3 anni 3 years

116PX LOW

VITROFLEX

Isolamento flessibile spessore 100 mm

Flexible insulation 100 mm thick

	Codice Code	€	Classe Energetica ErP
2500	116PX02500SB		-
3000	116PX03000SB		-
3000B	116PX03000SBB		-
4000	116PX04000SB		-
4000B	116PX04000SBB		-
5000	116PX05000SB		-

116PX LOW

VITROFLEX

Isolamento flessibile spessore 130 mm

Flexible insulation 130 mm thick

	Codice Code	€	Classe Energetica ErP
1500	116PX01500SB		C
2000	116PX02000SB		C

Listino prezzi accessori e ricambi a pagina 116

Accessories and spare parts price list available at page 116

Prodotti conformi alla direttiva 2014/68/UE PED (Art.4 Par.3)

Products complying with the directive 2014/68/UE PED (Art.4 Par.3)



Esempio di impianto Example of a system

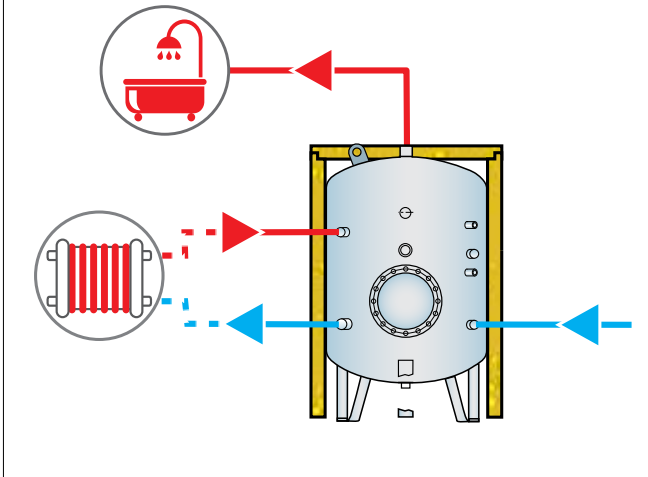

Disegno tecnico Technical drawing

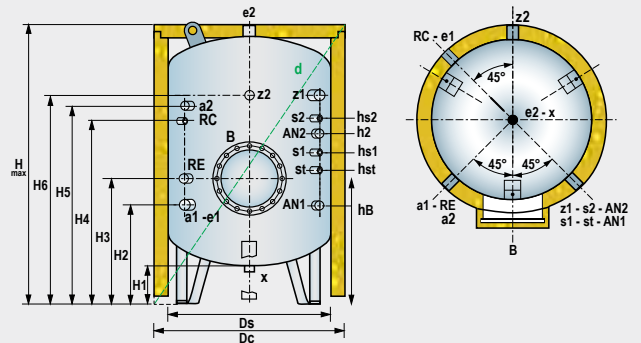

a1	Entrata circuito primario Primary circuit inlet
a2	Uscita circuito primario Primary circuit inlet
e1	Entrata acqua sanitaria Domestic water inlet
e2	Uscita acqua sanitaria Domestic water outlet
AN1-AN2	Anodi Anodes

RE	Attacco resistenza elettrica Electric heater fitting
s1-s2	Attacco sonda ausiliaria Auxiliary probe fitting
st	Attacco sonda temperatura Temperature probe fitting
z1	Attacco ausiliario 1500÷2500 lt. Auxiliary fitting 1500÷2500 lt.

z2	Attacco ausiliario 3000÷5000 lt. Auxiliary fitting 3000÷5000 lt.
RC	Ricircolo Recirculation
X	Scarico Drain
B	Boccaporto Inspection opening

lt	CONNESSIONI CONNECTIONS											
	a1	a2	e1	e2	AN1÷AN3	RE	s1 - s2	st	z1 - z2	RC	X	B
1500÷5000	G1"1/4-F	G1"1/4-F	G3"-F	G3"-F	G1"1/4-F	G2"-F	G1/2"-F	G1/2"-F	G2"-F	G1"-F	3"	øe 510 øi 410

lt	DIMENSIONALE SIZES (mm)															Peso Weight (Kg)	
	Ds	Dc	Hmax	H1	H2	H3	H4	H5	H6	Sonde Probes			Anodi Anodes		HB		d
		116PX LOW								hst	hs1	hs2	h1	h2			
1500 SB	1100	1360	2080	170	495	685	1120	1235	1595	720	920	1420	470	1120	685	2545	240
2000 SB	1250	1510	2080	150	520	745	1345	1460	1570	745	945	1395	495	1145	745	2630	285
2500 SB	1400	1600	2000	155	560	850	1185	1300	1410	785	985	1285	535	1185	850	2585	310
3000 SB	1600	1800	2000	130	575	865	1200	1315	1400	800	1000	1400	550	1200	865	2715	350
3000 SBB	1400	1600	2300	155	560	850	1385	1500	1810	785	1185	1685	535	1485	850	2815	350
4000 SB	1900	2100	2000	130	640	930	1165	1350	1390	865	1015	1350	615	1165	865	2925	450
4000 SBB	1600	1800	2500	130	575	865	1400	1515	1925	800	1285	1800	550	1650	865	3100	450
5000 SB	1900	2100	2250	120	630	855	1405	1520	1630	855	1055	1505	605	1255	855	3100	600



316

Accumuli d'acqua calda sanitaria con scambiatore a piastre
DHW storage tanks with plate heat exchanger

I prodotti della serie 316 sono serbatoi per acqua calda sanitaria. Indicati ad essere installati negli impianti ove il prelievo di acqua calda sanitaria raggiunge punte di richiesta elevate.

Il modello 316 è dotato di uno scambiatore di calore esterno del tipo a piastre ispezionabili, della idonea pompa di circolazione (lato sanitario) e dei collegamenti idrici fra scambiatore e accumulatore.



The 316 series products are domestic hot water tanks. Ideal for installation in systems where domestic hot water delivery has high peaks.

Model 316 is fitted with an external plate heat exchanger, openable for inspection, a special circulating pump (domestic hot water side) and water connections between the heat exchanger and storage tank.

Tutti i serbatoi coibentati rispettano i requisiti richiesti dalle direttive 2009/125/CE e 2010/30/UE sull'efficienza energetica.

All the insulated tanks, comply with the directive 2009/125/CE and 2010/30UE about energy efficiency.

CARATTERISTICHE TECNICHE TECHNICAL FEATURES

Costruzione accumulatore <i>Storage tank construction</i>	Acciaio al carbonio di elevata qualità <i>High quality carbon steel</i>
Trattamento interno <i>Inside treatment</i>	VITROFLEX idoneo per acqua uso alimentare secondo le direttive CE, D.M. 174/ GREZZO <i>VITROFLEX corrosion-proofing suitable for drinking water in accordance with EC directives / RAW</i>
Isolamento Rimovibile <i>Removable Insulation</i>	ECOFIRE, 300÷1000 lt. spessore 100 mm <i>ECOFIRE, 300÷1000 lt. 100 mm thick</i>
	ECOFIRE, 1500÷2000 lt. spessore 130 mm <i>ECOFIRE, 1500÷2000 lt. 130 mm thick</i>
	ECOFIRE, 3000÷5000 lt. spessore 100 mm <i>ECOFIRE, 3000÷5000 lt. 100 mm thick</i>
Rivestimento esterno <i>Outside covering</i>	PVC accoppiato <i>Laminated PVC</i>
Accumulatore <i>Storage tank</i>	Pmax 8 bar - Tmax 90°C
Scambiatore a piastre <i>Plate heat exchanger</i>	Pmax 10 bar - Tmax 140°C Acciaio inox AISI 316L, ispezionabili <i>AISI 316L stainless steel, openable for inspections</i>
Pompa <i>Pump</i>	Pmax 10 bar - Tmax 60°C Circolatore singolo a tre velocità <i>Single three-speed pump</i>
Accessori di serie <i>Standard accessories</i>	Anodo/i di magnesio con tester di controllo <i>Magnesium anode/anodes with tester</i>
Garanzia <i>Warranty</i>	3 anni <i>3 years</i>

Uso: acqua calda sanitaria
Use: domestic hot water

Abbinabile con:
Combined with:



Esempio di impianto Example of a system

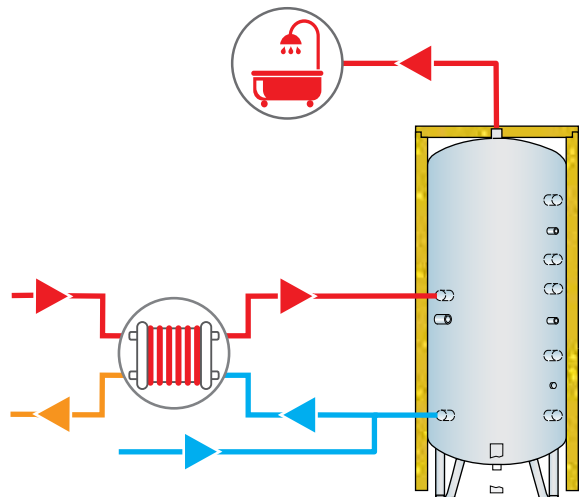

Disegno tecnico Technical drawing

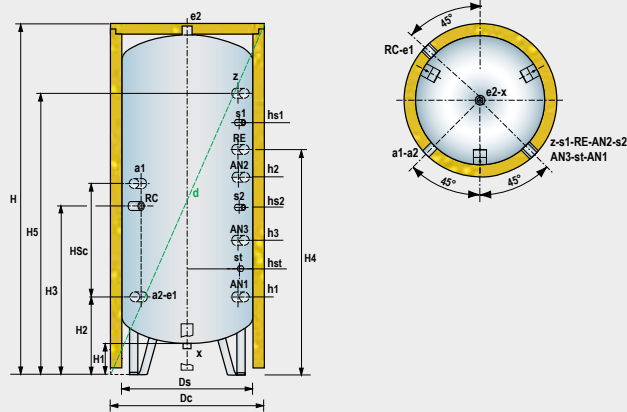

a1	Entrata circuito secondario Secondary circuit inlet
a2	Uscita circuito secondario Secondary circuit outlet
e1	Entrata acqua sanitaria Domestic water inlet
e2	Uscita acqua sanitaria Domestic water outlet

AN3	Anodo 300÷800 lt Anode 300÷800 lt
AN1-AN2	Anodi 1000÷5000 lt Anodes 1000÷5000 lt
RE	Attacco resistenza elettrica Electric heater fitting
Z	Attacco ausiliario Auxiliary fitting

s1-s2	Attacco sonda ausiliaria Auxiliary probe fitting
st	Attacco sonda temperatura Temperature probe fitting
RC	Ricircolo Recirculation
X	Scarico Drain

lt	CONNESSIONI CONNECTIONS										
	a1	a2	e1	e2	AN1÷AN3	RE	Z	s	st	RC	X
300÷1000	G1"1/4-F	G1"1/4-F	G1"1/4-F	G1"1/2-F	G1"1/4-F	G2"-F	-	G1/2"-F	G1/2"-F	G1"-F	G1"1/4-F
1500÷5000	G1"1/4-F	G1"1/4-F	G3"-F	G3"-F	G1"1/4-F	-	G2"-F	G1/2"-F	G1/2"-F	G1"-F	G3"-F

lt	DIMENSIONALE SIZES (mm)																Peso Weight (Kg)
	Ds	Dc	H	H1	H2	H3	H4	H5	HSc	Sonde Probes			Anodi Anodes			d	
										hst	hs1	hs2	h1	h2	h3		
300	550	750	1580	165	390	930	980	-	880	525	1280	-	-	-	700	1770	55
500	650	850	1895	155	410	1050	1190	-	940	540	1500	-	-	-	720	2095	84
800	790	990	1940	145	430	1170	1170	-	940	585	1520	-	-	-	920	2200	106
1000	790	990	2190	145	445	1170	1570	-	940	655	1720	-	420	1170	-	2420	125
1500	950	1210	2530	185	485	1310	-	2135	940	710	1960	1150	460	1510	-	2860	235
2000	1100	1360	2580	170	495	1320	-	2145	940	720	1970	1205	470	1520	-	2975	280
3000	1250	1450	2795	150	520	1345	-	2370	940	745	2245	1230	495	1745	-	3170	303
4000	1400	1600	2895	155	560	1385	-	2410	940	785	2285	1270	535	1785	-	3330	477
5000	1600	1800	2930	130	575	1400	-	2425	940	800	2300	1285	550	1800	-	3460	560

Heating



PRESTAZIONI PERFORMANCE

N°	W	Cond. 1			Cond. 2		
		KW	1 l/h	2 l/h	KW	1 l/h	2 l/h
11	60	36	1258	850	32	1387	840
15	60	58	1998	1350	51	2204	1340
19	60	77	2664	1800	68	2933	1780
23	60	98	3367	2275	86	3711	2250
25	60	108	3737	2525	96	4119	2500
27	60	125	4292	2900	110	4730	2870
31	60	143	4921	3325	126	5427	3300
33	80	161	5550	3750	142	6115	3700
37	80	178	6142	4150	157	6775	4100

Cond. 1. Temperatura di ingresso/uscita circuito primario di 80/55°C e di ingresso/uscita sanitario di 8/45°C.

Cond. 2. Temperatura di ingresso/uscita circuito primario di 80/60°C e di ingresso/uscita sanitario di 12/45°C.

Operating conditions:

Cond. 1. Primary circuit inlet/outlet temperature 80/55°C and domestic hot water inlet/outlet temperature 8/45°C.

Cond. 2. Primary circuit inlet/outlet temperature 80/60°C and domestic hot water inlet/outlet temperature 12/45°C.

	Capacità accumulo (lt.) Storage tank capacity (lt.)
	Potenza di scambio (Kw) Heat exchanger power (Kw)

	Numero di piastre. Number of plates.
	Portata primario (l/h) Primary flow-rate (l/h)

	Potenza pompa (W). Pump power (W).
	Portata secondario (l/h) Secondary flow-rate (l/h)

Disegno scambiatore a piastre Plate heat exchanger technical drawing

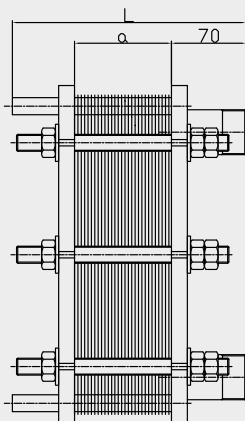
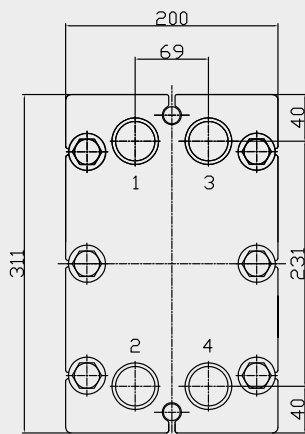



CONNESSIONI CONNECTIONS G 1" 1/4



1. Ingresso primario
primary inlet
2. Uscita primario
primary outlet
3. Uscita secondario
secondary outlet
4. Ingresso secondario
secondary inlet

Uso: acqua calda sanitaria
Use: domestic hot water

Abbinabile con:
Combined with:



316PX VITROFLEX Isolamento flessibile <i>Flexible insulation</i>				
	Codice Code		€	Classe Energetica ErP
300 100 mm spessore thick	316PX0300/11	11		C
	316PX0300/15	15		C
	316PX0300/19	19		C
	316PX0300/23	23		C
	316PX0300/25	25		C
	316PX0300/27	27		C
	316PX0300/31	31		C
	316PX0300/33	33		C
	316PX0300/37	37		C
500 100 mm spessore thick	316PX0500/11	11		C
	316PX0500/15	15		C
	316PX0500/19	19		C
	316PX0500/23	23		C
	316PX0500/25	25		C
	316PX0500/27	27		C
	316PX0500/31	31		C
	316PX0500/33	33		C
316PX0500/37	37		C	
800 100 mm spessore thick	316PX0800/11	11		C
	316PX0800/15	15		C
	316PX0800/19	19		C
	316PX0800/23	23		C
	316PX0800/25	25		C
	316PX0800/27	27		C
	316PX0800/31	31		C
	316PX0800/33	33		C
	316PX0800/37	37		C
1000 100 mm spessore thick	316PX1000/11	11		C
	316PX1000/15	15		C
	316PX1000/19	19		C
	316PX1000/23	23		C
	316PX1000/25	25		C
	316PX1000/27	27		C
	316PX1000/31	31		C
	316PX1000/33	33		C
	316PX1000/37	37		C
1500 130 mm spessore thick	316PX1500/11	11		C
	316PX1500/15	15		C
	316PX1500/19	19		C
	316PX1500/23	23		C
	316PX1500/25	25		C
	316PX1500/27	27		C
	316PX1500/31	31		C
	316PX1500/33	33		C
	316PX1500/37	37		C

	Codice Code		€	Classe Energetica ErP
2000 130 mm spessore thick	316PX2000/11	11		C
	316PX2000/15	15		C
	316PX2000/19	19		C
	316PX2000/23	23		C
	316PX2000/25	25		C
	316PX2000/27	27		C
	316PX2000/31	31		C
3000 100 mm spessore thick	316PX3000/11	11		-
	316PX3000/15	15		-
	316PX3000/19	19		-
	316PX3000/23	23		-
	316PX3000/25	25		-
	316PX3000/27	27		-
	316PX3000/31	31		-
4000 100 mm spessore thick	316PX4000/11	11		-
	316PX4000/15	15		-
	316PX4000/19	19		-
	316PX4000/23	23		-
	316PX4000/25	25		-
	316PX4000/27	27		-
	316PX4000/31	31		-
5000 100 mm spessore thick	316PX5000/11	11		-
	316PX5000/15	15		-
	316PX5000/19	19		-
	316PX5000/23	23		-
	316PX5000/25	25		-
	316PX5000/27	27		-
	316PX5000/31	31		-
316PX5000/33	33		-	
316PX5000/37	37		-	

Listino prezzi accessori e ricambi a pagina 116
Accessories and spare parts price list available at page 116



EOP Bollitore orizzontale con scambiatore estraibile

Horizontal storage tank with removable heat exchanger



I prodotti della serie EOP sono bollitori orizzontali per la produzione e l'accumulo di acqua calda sanitaria. Gli scambiatori di calore sono a fascio tubiero estraibile, con tubi in acciaio inossidabile mandrinati su piastra in acciaio trattata VITROFLEX. Una grande potenzialità di scambio unita a perdite di carico trascurabili li rendono il compromesso ideale fra potenza installata e volume d'acqua calda accumulato, sono ideali per impianti sanitari ove il prelievo di acqua calda raggiunge punte di richiesta elevate (centri sportivi, ospedali, piscine, impianti civili centralizzati...).



The EOP series products are horizontal storage tanks for the production and storage of domestic hot water. The heat exchangers used are removable U-shaped tube bundles, made by stainless steel tubes expanded onto steel plates with VITROFLEX treatment. These storage tanks, with high heat exchange capacity and low pressure drop, represents the best compromise between installed power and volume of hot water stored, making them ideal for connection to domestic hot water systems where delivery of hot water has very high peaks (sports centres, hospitals, swimming pools, centralised residential systems,...).

Tutti i serbatoi coibentati rispettano i requisiti richiesti dalle direttive 2009/125/CE e 2010/30/UE sull'efficienza energetica.

All the insulated tanks, comply with the directive 2009/125/CE and 2010/30UE about energy efficiency.

CARATTERISTICHE TECNICHE TECHNICAL FEATURES

Costruzione accumulo <i>Storage tank construction</i>	Acciaio al carbonio di elevata qualità <i>High quality carbon steel</i>
Trattamento interno <i>Inside treatment</i>	VITROFLEX idoneo per acqua uso alimentare secondo le direttive CE, D.M. 174/ GREZZO <i>VITROFLEX corrosion-proofing suitable for drinking water in accordance with EC directives / RAW</i>
Isolamento Rimovibile <i>Removable Insulation</i>	ECOFIRE, 500÷1000 lt. spessore 100 mm <i>ECOFIRE, 500÷1000 lt. 100 mm thick</i>
	ECOFIRE, 1500÷2000 lt. spessore 130 mm <i>ECOFIRE, 1500÷2000 lt. 130 mm thick</i>
	ECOFIRE, 2500÷5000 lt. spessore 100 mm <i>ECOFIRE, 2500÷5000 lt. 100 mm thick</i>
Rivestimento esterno <i>Outside covering</i>	PVC accoppiato <i>Laminated PVC</i>
Accumulo <i>Storage tank</i>	Pmax 8 bar - Tmax 90°C
Scambiatore <i>Heat exchanger</i>	Pmax 12 bar - Tmax 110°C Estraibile acciaio inox <i>Removable stainless steel</i>
Accessori di serie <i>Standard accessories</i>	Anodo/i di magnesio con tester di controllo <i>Magnesium anode/anodes with tester</i>
Garanzia <i>Warranty</i>	3 anni <i>3 years</i>

Uso: acqua calda sanitaria
Use: domestic hot water

Abbinabile con:
Combined with:



Esempio di impianto *Example of a system*

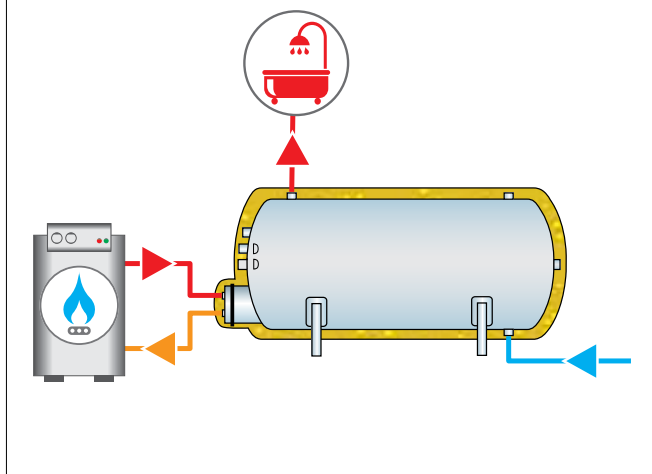

Disegno tecnico *Technical drawing*

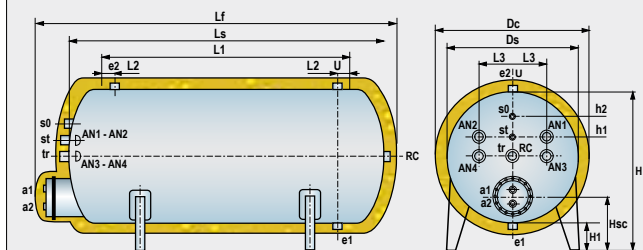

a1	Entrata circuito primario Primary circuit inlet
a2	Uscita circuito primario Primary circuit outlet
e1	Entrata acqua sanitaria Domestic water inlet
e2	Uscita acqua sanitaria Domestic water outlet

AN1	Anodo 500 lt Anode 500 lt
AN1-AN2	Anodi 800-1000 lt Anodes 800-1000 lt
AN3-AN4	Anodi 1500+5000 lt Anodes 1500+5000 lt
s0	Attacco sonda ausiliaria Auxiliary probe fitting

st	Attacco sonda temperatura Temperature probe fitting
tr	Attacco termoregolatore Temperature controller fitting
RC	Ricircolo - Resistenza elettrica Recirculation - Electrical Resistance
U	Servizio Service

lt	CONNESSIONI CONNECTIONS									
	a1	a2	e1	e2	AN1÷AN4	s0	st	tr	RC	U
500	G1"-F	G1"-F	G1"1/4-F	G1"1/4-F	G1"1/4-F	G1/2"-F	G1/2"-F	G1"1/4-F	G1"1/4-F	G3/4"-F
800÷1000	G2"-F	G2"-F	G1"1/4-F	G1"1/4-F	G1"1/4-F	G1/2"-F	G1/2"-F	G1"1/4-F	G1"1/4-F	G3/4"-F
1500÷3000	G2"-F	G2"-F	G2"-F	G2"-F	G1"1/4-F	G1/2"-F	G1/2"-F	G1"1/4-F	G1"1/4-F	G3/4"-F
4000÷5000	G2"-F	G2"-F	G3"-F	G3"-F	G1"1/4-F	G1/2"-F	G1/2"-F	G1"1/4-F	G1"1/4-F	G3/4"-F

lt	DIMENSIONALE SIZES (mm)											Peso Weight (Kg)	
	Ds	Dc	Ls	Lf	L1	L2	L3	H	H1	HSc	h1		h2
500	650	850	1640	1960	1250	65	150	805	155	305	580	675	115
800	790	990	1700	2050	1250	65	200	935	145	335	665	795	150
1000	790	990	1950	2295	1500	65	200	935	145	335	665	795	170
1500	950	1210	2240	2570	1800	75	230	1175	225	415	875	1025	265
2000	1100	1360	2290	2590	1800	75	260	1305	205	420	955	1155	330
2500	1250	1450	2380	2680	1800	75	270	1380	130	345	930	1230	345
3000	1250	1450	2580	2930	2000	75	270	1380	130	345	930	1230	370
4000	1400	1600	2650	2995	2000	85	300	1570	165	385	1020	1420	555
5000	1600	1800	2730	3025	2000	85	300	1750	150	365	1050	1600	645



PRESTAZIONI PERFORMANCE

lt	m ²	KW ⁽¹⁾	l/h	min ⁽²⁾	l/h ⁽³⁾	l/10' ⁽³⁾
500	1	32	2752	63	834	366
800	1.5	56	4816	57	1459	607
1000	2	74	6364	54	1929	776
1500	3	94	8084	64	2450	1090
2000	4	150	12900	54	3909	1561
2500	5	174	14964	58	4535	1892
3000	6	200	17200	60	5212	2232
4000	8	289	24854	56	7532	3073
5000	10	336	28896	60	8756	3732

(1) Potenza termica dello scambiatore calcolata ipotizzando una temperatura di ingresso/uscita circuito primario di 80/70°C e di ingresso sanitario di 12°C;

(2) Tempo necessario per innalzare la temperatura dell'acqua in ingresso sanitario, 12°C, alla temperatura di accumulo pari a 60°C;

(3) Quantità di acqua calda sanitaria disponibile alla temperatura di utilizzo di 45°C in continuo o nei primi 10 minuti.

(1) Heat exchanger output calculated assuming a primary circuit inlet/outlet temperature of 80/70°C and a DHW inlet temperature of 12°C;

(2) Time needed to increase the domestic water inlet temperature, 12°C, to the storage temperature of 60°C;

(3) Quantity of domestic hot water available at a delivery temperature of 45°C, continuously or in the first 10 minutes.

TABELLA SCAMBIATORI HEAT EXCHANGER TABLE

lt	500	800	1000	1500	2000	2500	3000	4000	5000
Di serie Standard (m ²)	Sc	Sc	Sc	Sc	Sc	Sc	Sc	Sc	Sc
	1	1.5	2	3	4	5	6	8	10
Optional (m ²)	0.75	2	1.5	1.5	5	4	4	4	4
		3	3	2	6	6	5	5	5
								6	6
									8

DATI SCAMBIATORI HEAT EXCHANGER DATA

m ²	0.75	1	1.5	2	3	4	5	6	8	10
KW	27	32	56	74	94	150	174	200	289	336
lt	4	5	8.5	10.5	14	19	22	24.8	33	40
mm	300	300	380	380	380	430	430	430	430	430



Capacità accumulo (lt.)
Storage tank capacity (lt.)



Portata primario (l/h)
Primary flow-rate (l/h)



Portata ACS nei primi 10 min.
DHW flow-rate in the first 10 min.



Superficie di scambio (m²)
Heat exchanger surface (m²)



Tempo di messa a regime (min.)
Time to reach temperature (min.)



Contenuto acqua scambiatore (lt.)
Heat exchanger capacity (lt.)



Potenza di scambio (Kw)
Heat exchanger power (Kw)



Portata ACS (l/h)
DHW flow-rate (l/h)



Diametro flangia scambiatore
Heat exchanger diameter flange

Uso: acqua calda sanitaria
Use: domestic hot water

Abbinabile con:
Combined with:





EOPX

VITROFLEX

Isolamento flessibile spessore **100 mm**

Flexible insulation **100 mm** thick



	Codice Code		€	Classe Energetica ErP
500	EOPX0500	1		C
800	EOPX0800	1.5		C
1000	EOPX1000	2		C
2500	EOPX2500	5		-
3000	EOPX3000	6		-
4000	EOPX4000	8		-
5000	EOPX5000	10		-

EOPX

VITROFLEX

Isolamento flessibile spessore **130 mm**

Flexible insulation **130 mm** thick

	Codice Code		€	Classe Energetica ErP
1500	EOPX1500	3		C
2000	EOPX2000	4		C

Listino prezzi accessori e ricambi a pagina 116

Accessories and spare parts price list available at page 116



EVAP

Bollitore con scambiatore estraibile per vapore
Storage tank with removable heat exchanger for steam



EVAP è un bollitore per la produzione e l'accumulo di acqua calda sanitaria. Gli scambiatori di calore a fascio tubiero estraibile, sono realizzati con tubi in acciaio inossidabile e mandrinati su piastra INOX 316L e costruiti secondo la normativa P.E.D., rendendoli così idonei per vapore o acqua surriscaldata.



EVAP is a boiler for the production and storage of domestic hot water. The extractable shell and tube heat exchangers, are made with stainless steel tubes and expanded on 316L stainless steel plate and built according to the P.E.D. standard, thus making them suitable for steam or superheated water.

CARATTERISTICHE TECNICHE TECHNICAL FEATURES

Costruzione accumulo <i>Storage tank construction</i>	Acciaio al carbonio di elevata qualità <i>High quality carbon steel</i>
Trattamento interno <i>Inside treatment</i>	VITROFLEX idoneo per acqua uso alimentare secondo le direttive CE, D.M. 174 / GREZZO <i>VITROFLEX corrosion-proofing suitable for drinking water in accordance with EC directives / RAW</i>
Isolamento Rimovibile <i>Removable Insulation</i>	ECOFIRE, 500÷1000 lt. spessore 100 mm <i>ECOFIRE, 500÷1000 lt. 100 mm thick</i>
	ECOFIRE, 1500÷2000 lt. spessore 130 mm <i>ECOFIRE, 1500÷2000 lt. 130 mm thick</i>
	ECOFIRE, 2500÷5000 lt. spessore 100 mm <i>ECOFIRE, 2500÷5000 lt. 100 mm thick</i>
Rivestimento esterno <i>Outside covering</i>	PVC accoppiato <i>Laminated PVC</i>
Accumulo <i>Storage tank</i>	Pmax 8 bar - Tmax 80°C
Scambiatore di serie <i>Standard heat exchanger</i>	Pmax 12 bar - Tmax 191.6°C Rimovibile acciaio INOX 316L attacchi filettati - <i>Removable Stainless Steel 316L threaded connection</i>
Scambiatore optional <i>Heat exchanger optional</i>	Pmax 6 bar - Tmax 164.9°C Rimovibile in acciaio INOX AISI 316L - <i>Removable Stainless Steel Material 316L</i>
Accessori di serie <i>Standard accessories</i>	Anodo/i di magnesio con tester di controllo <i>Magnesium anode/anodes with tester</i>
Garanzia <i>Warranty</i>	3 anni <i>3 years</i>

EVAP

VITROFLEX

Isolamento flessibile spessore **100 mm**

Flexible insulation 100 mm thick

	Codice Code		€	Classe Energetica ErP
500	EVPXXV0500	1		C
800	EVPXXV0800	1.5		C
1000	EVPXXV1000	2		C
2500	EVPXXV2500	3		-
3000	EVPXXV3000	3		-
4000	EVPXXV4000	4		-
5000	EVPXXV5000	5		-

EVAP

VITROFLEX

Isolamento flessibile spessore **130 mm**

Flexible insulation 130 mm thick

	Codice Code		€	Classe Energetica ErP
1500	EVPXXV1500	3		C
2000	EVPXXV2000	3		C

Listino prezzi accessori e ricambi a pagina 116
Accessories and spare parts price list available at page 116

Usò: acqua calda sanitaria
Use: domestic hot water

Abbinabile con:
Combined with:



Disegno tecnico Technical drawing

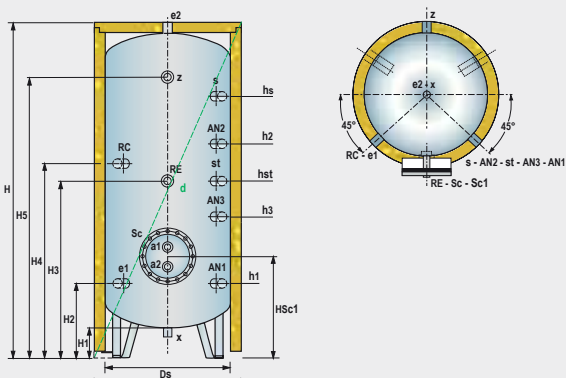

a1	Entrata circuito primario Primary circuit inlet	tr	Attacco termoregolatore Temperature control fitting
a2	Uscita circuito primario Primary circuit inlet	Z	Attacco ausiliario Auxiliary fitting
e1	Entrata acqua sanitaria Domestic water inlet	s	Attacco sonda ausiliaria Auxiliary probe fitting
e2	Uscita acqua sanitaria Domestic water outlet	st	Attacco sonda temperatura Temperature probe fitting
AN3	Anodo 500÷800 lt Anode 500÷800 lt	RC	Ricircolo Recirculation
AN1-AN2	Anodo 1000÷5000 lt Anode 1000÷5000 lt	X	Scarico Drain

Esempio di impianto Example of a system

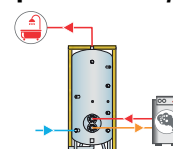

lt	CONNESSIONI CONNECTIONS										
	a1	a2	e1	e2	AN1÷AN3	tr	Z	s	st	RC	X
500÷1000	G2"-F	G2"-F	G1"1/4-F	G1"1/2-F	G1"1/4-F	G1"-F	-	G1/2"-F	G1/2"-F	G1"-F	G1"1/4-F
1500÷5000	G2"-F	G2"-F	G3"-F	G3"-F	G1"1/4-F	G1"-F	G2"-F	G1/2"-F	G1/2"-F	G1"-F	G1"1/4-F

lt	DIMENSIONALE SIZES (mm)															Peso Weight (Kg)
	Ds	Dc	H	H1	H2	H3	H4	H5	HSc	Sonde Probes		Anodi Anodes			d1	
										hst	hs	h1	h2	h3		
500	650	850	1895	155	415	855	1055	-	595	855	1405	-	-	725	2095	110
800	790	990	1940	145	430	870	1070	-	610	870	1420	-	-	1000	2200	150
1000	790	990	2190	145	430	1070	1170	-	660	1070	1670	420	1370	-	2420	170
1500	950	1210	2530	185	485	1210	1510	2135	730	1210	1960	460	1560	-	2860	260
2000	1100	1360	2580	170	495	1220	1520	2145	740	1220	1970	470	1570	-	2975	330
2500	1250	1450	2605	150	510	1235	1535	2160	755	1235	1985	485	1585	-	3000	345
3000	1250	1450	2795	150	510	1235	1685	2360	755	1235	2235	485	1735	-	3170	370
4000	1400	1600	2895	185	590	1305	1755	2430	825	1305	2305	555	1805	-	3330	560
5000	1600	1800	2930	130	575	1290	1740	2415	810	1290	2290	540	1790	-	3460	650

Su richiesta e possibile avere gli attacchi flangiati allo scambiatore di calore
On request heat exchange can be provided with Flanged connection

PRESTAZIONI PERFORMANCE						
lt	m ²	KW ⁽¹⁾	l/h	min ⁽²⁾	l/h ⁽³⁾	mm
500	1	140	3441	9	1098	300
800	1.5	215	5203	9	1801	380
1000	2	280	6941	9	2412	380
1500	3	420	10311	8	3601	380
2000	3	430	10311	12	4199	380
2500	3	430	10311	13	4598	380
3000	3	430	10311	16	5380	380
4000	4	555	13902	17	7120	430
5000	5	710	17541	18	8992	430

(1) Valori calcolati con scambiatore alimentato a 6 bar e secondario 10°C e 45°C.
(1) Values calculated with heat exchanger powered at 6 bar and secondary at 10 °C and 45 °C.

Accumulo conforme alla direttiva 2014/68/EU (Art.4 Par.3) Scambiatore conforme alla direttiva 2014/68/EU (Cat. 1 Mod.A)
Storage Tank according to Directive 2014/68 / EU (Art.4 Par.3) Heat exchanger according to directive 2014/68/EU (Cat. 1 Mod.A)



I prodotti della serie 217 sono vasi d'espansione, collaudati 2014/68/UE PED, idonei ad assorbire l'aumento di volume del fluido contenuto nell'impianto e, contemporaneamente, a mantenere la pressione entro i limiti di funzionamento.



The 217 series products are expansion vessels tested in compliance with 2014/68/UE PED, suitable for absorbing the increase in fluid volume in the system and, at the same time, maintaining the pressure within the operating limits.

CARATTERISTICHE TECNICHE TECHNICAL FEATURES

Costruzione accumulo Storage tank construction	Acciaio al carbonio di elevata qualità High quality carbon steel	
Trattamento esterno Outside treatment	217V	Verniciatura Painted
	217Z	Zincatura a bagno caldo Hot dip galvanisation
Accumulo Storage tank	Pmax 8 bar Tmin -10°C Tmax + 175,4°C	
Garanzia Warranty	2 anni 2 years	

Utilizzo: Versione 8 bar per uso con aria + acqua + vapore d'acqua (temperatura max vapore d'acqua vedi tabella)
Use: Version 8 bar for use with air + water + vapor of water (maximum temperature water vapor see table)

217V
VERNICIATURA
PAINTED

lt	Codice Code	bar	€	Classe Energetica ErP
500	217V0500/08	8		-
800	217V0800/08			-
1000	217V1000/08			-
1500	217V1500/08			-
2000	217V2000/08			-
3000	217V3000/08			-
4000	217V4000/08			-
5000	217V5000/08			-

217Z
ZINCATURA A BAGNO CALDO
HOT DIP GALVANISATION

lt	Codice Code	bar	€	Classe Energetica ErP
500	217Z0500/08	8		-
800	217Z0800/08			-
1000	217Z1000/08			-
1500	217Z1500/08			-
2000	217Z2000/08			-
3000	217Z3000/08			-
*4000	217Z4000/08			-
*5000	217Z5000/08			-

Listino prezzi accessori e ricambi a pagina 116
Accessories and spare parts price list available at page 116

* 4000L e 5000L comprensivo di apertura d'ispezione 300x400.
Per tutte le altre capacità optional.
* 4000L & 5000L C/W inspection opening 300x400, for other capacities on request only.

Prodotti conformi alla direttiva 2014/68/UE PED
Products complying with the directive 2014/68/UE PED

Disegno tecnico Technical drawing

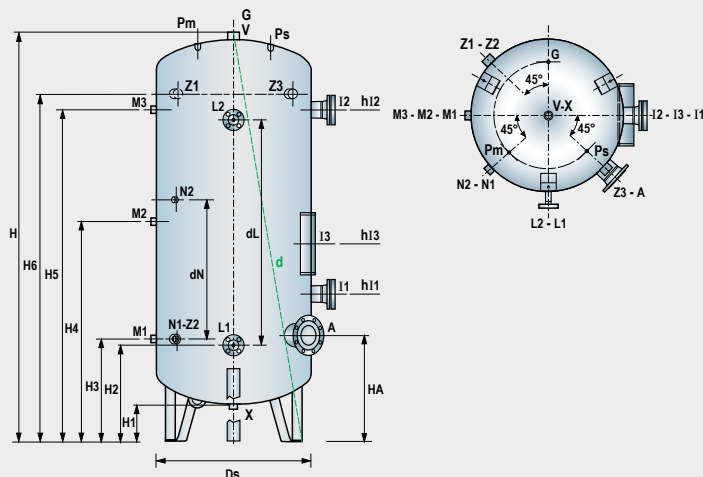

A	Collegamento d'impianto Connection to the system
L1-L2	Attacco indicatore di livello Level gauge fitting
M1-M2-M3	Attacco regolatore di livello massimo Maximum level control fitting
N1-N2	Attacco regolatore di livello minimo Minimum level control fitting

Pm	Attacco manometro Pressure gauge fitting
Ps	Attacco pressostato Pressure switch fitting
G	Ingresso gas di pressurizzazione Pressurisation gas inlet
V	Attacco valvola di sicurezza Safety valve fitting

Z1	Attacco ausiliario 1500÷5000 lt Auxiliary fitting 1500÷5000 lt
Z2-Z3	Attacco ausiliario 2500÷5000 lt Auxiliary fitting 2500÷5000 lt
I1-I2-I3	Aperture d'ispezione (solo su richiesta) Inspection opening (only upon request)
X	Scarico Drain

lt	CONNESSIONI CONNECTIONS											
	A*	L1 - L2*	M1-M2-M3	N1-N2	Pm	Ps	G	V	Z1	Z2-Z3	I1-I2-I3	X
500	DN65	Dn20	NPT 1"-F	NPT 1"-F	G3/8"-F	G3/8"-F	G3/8"-F	G1"1/4-F	G2"-F	G2"-F	100x150	G1"1/4-F
800÷1000	DN80	Dn20	NPT 1"-F	NPT 1"-F	G3/8"-F	G3/8"-F	G3/8"-F	G1"1/4-F	G2"-F	G2"-F	100x150	G1"1/4-F
1500÷2000	DN100	Dn20	NPT 1"-F	NPT 1"-F	G3/8"-F	G3/8"-F	G3/8"-F	G1"1/4-F	G2"-F	G2"-F	100x150	G1"1/4-F
3000	DN125	Dn20	NPT 1"-F	NPT 1"-F	G3/8"-F	G3/8"-F	G3/8"-F	G1"1/4-F	G2"-F	G2"-F	300x400	G1"1/4-F
4000÷5000	DN150	Dn20	NPT 1"-F	NPT 1"-F	G3/8"-F	G3/8"-F	G3/8"-F	G1"1/4-F	G2"-F	G2"-F	300x400	G1"1/4-F

lt	DIMENSIONALE SIZES (mm)															Peso Weight (Kg)	
	Ds	H	HA	H1	H2	H3	H4	H5	H6	dN	dL	Aperture d'ispezione Inspection openings (optional)			d	Vern.	Zinc.
												h1	h2	h3			
500	600	1830	455	165	440	450	890	1450	-	640	1000	555	1405	-	1859	134	146
800	790	1980	575	235	550	560	1000	1560	-	640	1000	665	1515	-	2019	204	223
1000	790	2230	575	235	555	565	1170	1860	-	690	1295	665	1765	-	2265	227	249
1500	1000	2275	615	190	570	580	1255	1785	1845	780	1295	665	1765	955	2329	392	430
2000	1000	2775	620	190	580	590	1265	2295	2335	780	1590	-	-	955	2820	535	588
3000	1200	2935	735	230	685	695	1505	2285	2425	890	1590	-	-	840	2996	758	832
4000	1450	3070	815	180	740	750	1560	2340	2450	890	1590	-	-	1000	3154	1154	1267
5000	1450	3555	815	180	740	750	1765	2875	2950	1110	2125	-	-	1000	3628	1335	1466

* EN1092-1 type 11



Scambiatori a Piastre ispezionabili
Inspectable Plate Heat Exchanger



Gli scambiatori ispezionabili, sono costituiti da un pacco di piastre stampate in acciaio di altissima qualità e da guarnizioni adatte ai fluidi ed alle temperature richieste dall'applicazione. La particolare conformazione del canale creato da due piastre consente di raggiungere alti coefficienti di scambio, grande turbolenza e quindi sporco minimo.



The inspectable exchangers are made up of a pack of molded steel plates of the highest quality and gaskets suitable for the fluids and temperatures required by the application. The particular conformation of the channel created by two plates allows to reach high exchange coefficients, great turbulence and therefore minimal fouling.

CARATTERISTICHE TECNICHE TECHNICAL FEATURES

Materiale di Costruzione <i>Construction Material</i>	Acciaio inox AISI 316L <i>Stainless Steel AISI 316 L</i>
Scambiatore <i>Heat exchanger</i>	Pmax 10 bar - Tmax 140°C
Piastre <i>Plates</i>	Ispezionabili <i>Inspectable</i>
Garanzia <i>Warranty</i>	1 anno <i>1 year</i>

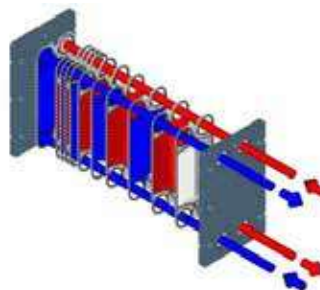
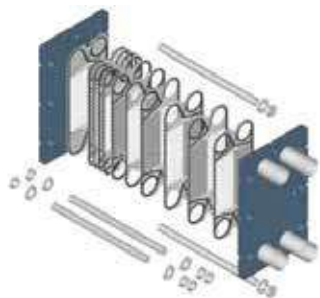

Disegno scambiatore a piastre Plate heat exchanger technical drawing

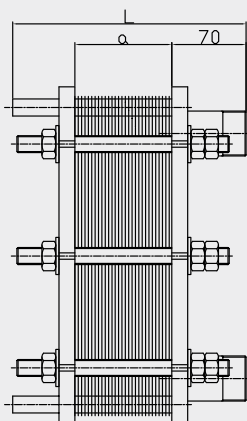
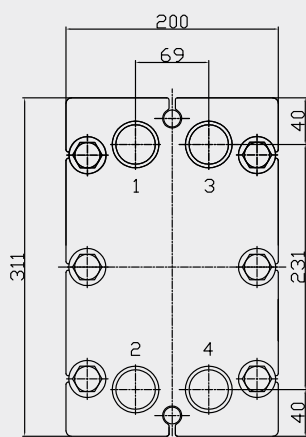

CONNESSIONI CONNECTIONS
G 1" 1/4

1. Ingresso primario
primary inlet
2. Uscita primario
primary outlet
3. Uscita secondario
secondary outlet
4. Ingresso secondario
secondary inlet

PRESTAZIONI PERFORMANCE						
	Cond. 1			Cond. 2		
11	36	1258	850	32	1387	840
15	58	1998	1350	51	2204	1340
19	77	2664	1800	68	2933	1780
23	98	3367	2275	86	3711	2250
25	108	3737	2525	96	4119	2500
27	125	4292	2900	110	4730	2870
31	143	4921	3325	126	5427	3300
33	161	5550	3750	142	6115	3700
37	178	6142	4150	157	6775	4100

Cond. 1. Temperatura di ingresso/uscita circuito primario di 80/55°C e di ingresso/uscita sanitario di 8/45°C.

Cond. 2. Temperatura di ingresso/uscita circuito primario di 80/60°C e di ingresso/uscita sanitario di 12/45°C.

Operating conditions:

Cond. 1. Primary circuit inlet/outlet temperature 80/55°C and domestic hot water inlet/outlet temperature 8/45°C.

Cond. 2. Primary circuit inlet/outlet temperature 80/60°C and domestic hot water inlet/outlet temperature 12/45°C.

SCAMBIATORI A PIASTRE ISPEZIONABILI OPENABLE PLATE HEAT EXCHANGERS

	L (mm)	Codice Code	€
11	220	1201128	
15	220	1201129	
19	220	1201130	
23	220	1201131	
25	220	1201132	
27	220	1201133	
31	220	1201134	
33	370	1201135	
37	370	1201136	



218 GP

Serbatoi inerziali per impianti di refrigerazione
Storage tanks for cooling systems



I prodotti della serie 218GP, sono accumulatori inerziali, idonei a funzionare come volani termici negli impianti di condizionamento e riscaldamento. Particolarmente adatto a POMPE DI CALORE, inoltre la serie pensile è progettata per l'installazione a parete.



The products of the 218GP series are inertial accumulators, suitable for functioning as thermal flywheels in air conditioning and heating systems. Particularly suitable for HEAT PUMPS, moreover the hanging series is designed for wall installation.

CARATTERISTICHE TECNICHE TECHNICAL FEATURES

Costruzione accumulo <i>Storage tank construction</i>	Acciaio al carbonio di elevata qualità <i>High quality carbon steel</i>
Trattamento interno <i>Inside treatment</i>	Grezzo <i>Raw</i>
Isolamento <i>Insulated</i>	Poliuretano rigido iniettato <i>Injected rigid polyurethane</i>
Rivestimento esterno <i>Outside covering</i>	Lamierino verniciato <i>Painted metal sheet</i>
Accumulo <i>Storage tank</i>	Pmax 6 bar - Tmax 99°C
Garanzia <i>Warranty</i>	2 anni <i>2 years</i>

218G PENSILE

GREZZO
RAW

	Codice Code	€	Classe Energetica ErP
50	218GP50		C
100	218GP100		C



Disegno tecnico *Technical drawing*

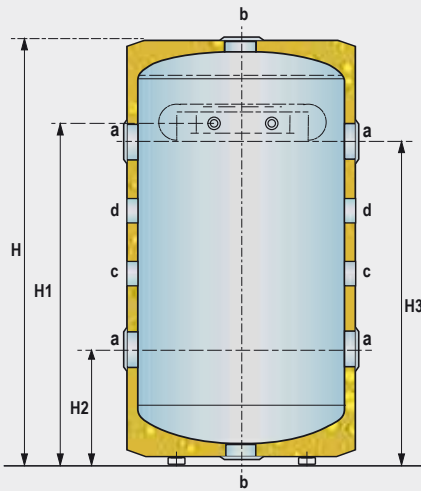

- a-a** Ingresso / uscita acqua
Water inlet / outlet
- b-b** Attacco valvola di sicurezza / scarico
Safety valve connection / drain

	DIMENSIONALE SIZES (mm)							Peso Weight (Kg)
	a-b	c-d	H	H1	H2	H3	De	
50	G1"1/2-F	-	520	370	180	355	440	18
100	G1"1/2-F	G1"1/2-F	915	765	230	690	440	29

Esempio di impianto *Example of a system*

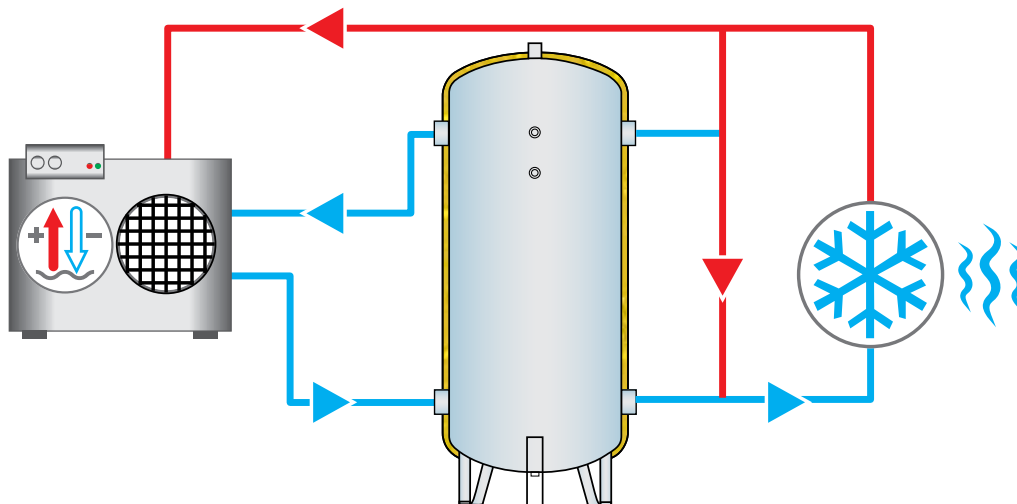



I prodotti della serie 218GHC sono accumulatori per acqua calda o refrigerata, idonei a funzionare come volani termici negli impianti di condizionamento e riscaldamento. Particolarmente adatto a POMPE DI CALORE grazie all'isolamento maggiorato di 50 mm di poliuretano iniettato volto ad assicurare minori dispersioni termiche in riscaldamento. Predisposto con ulteriori 2 attacchi per resistenze elettriche o per particolare circuitazioni.



The 218GHC series products are storage tanks for hot or chilled water, suitable for operation as buffer tanks in air-conditioning and heating systems. Suitable for heat pump thanks to thicker insulation of 50 mm injected rigid polyurethane. Particular insulation guarantees lower heat loss for heating system. It is also designed with 2 additional connections for electric resistance or for special requirements.

Tutti i serbatoi coibentati rispettano i requisiti richiesti dalle direttive 2009/125/CE e 2010/30/UE sull'efficienza energetica.

All the insulated tanks, comply with the directive 2009/125/CE and 2010/30UE about energy efficiency.

CARATTERISTICHE TECNICHE TECHNICAL FEATURES

Costruzione accumulo <i>Storage tank construction</i>	Acciaio al carbonio di elevata qualità <i>High quality carbon steel</i>
Trattamento interno <i>Inside treatment</i>	Grezzo <i>Raw</i>
Isolamento <i>Insulated</i>	200÷1000 lt. Poliuretano rigido iniettato 1500÷2000 lt. Anticondensa - Polistirolo rigido
Rivestimento esterno <i>Outside covering</i>	200÷1000 lt. Lamierino zincato verniciato, piedini ABS 1500÷2000 lt. Lamierino di alluminio goffrato
Accumulo <i>Storage tank</i>	Pmax 6 bar - Tmax 99°C
Garanzia <i>Warranty</i>	2 anni <i>2 years</i>

218GHC

GREZZO
RAW

lt	Codice Code	€	Classe Energetica ErP
200	218GHC0200		C
300	218GHC0300		C
500	218GHC0500		C
800	218GHC0800		C
1000	218GHC1000		C
1500	218GHC1500		C
2000	218GHC2000		C

Esempio di impianto Example of a system

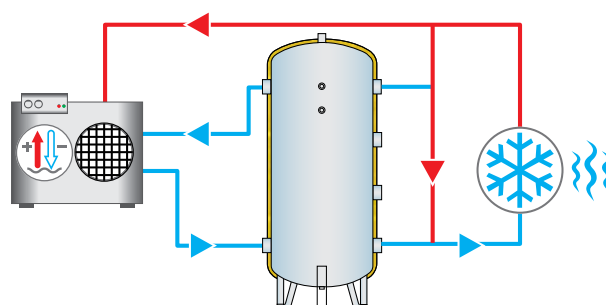

Usò: riscaldamento e raffreddamento
Use: heating and cooling

Abbinabile con:
Combined with:



Disegno tecnico *Technical drawing*

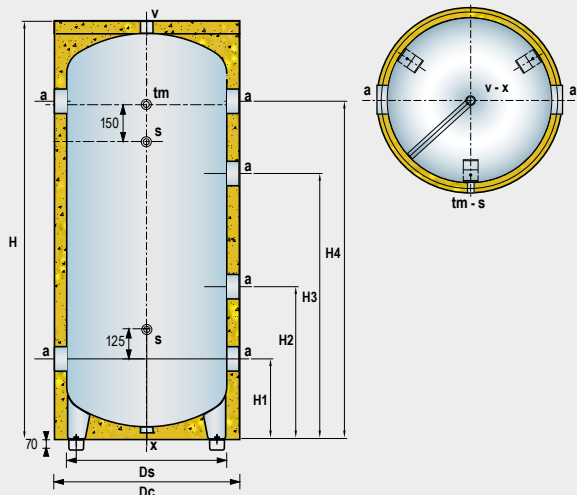

a-a	Ingresso / uscita acqua <i>Water inlet / outlet</i>
tm	Attacco termometro <i>Thermometer fitting</i>
s	Attacco sonda <i>Probe fitting</i>
v	Attacco valvola di sicurezza <i>Safety valve fitting</i>
x	Scarico <i>Drain</i>

	CONNESSIONI CONNECTIONS				
	a-a	tm	s	v	x
200	G2"-F	G1/2"-F	G1/2"-F	G1"1/4-F	G1"1/4-F
300÷1000	G3"-F	G1/2"-F	G1/2"-F	G1"1/4-F	G1"1/4-F

								Peso Weight (Kg)
	Dc	H	H1	H2	H3	H4	d	
200	550	1470	240	560	880	1200	1635	40
300	650	1410	265	545	835	1115	1616	49
500	750	1715	307	560	1130	1380	1936	84
800	890	1775	340	590	1160	1410	2010	115
1000	890	2027	340	700	1300	1660	2280	135
1500	1150	2550	500	800	1750	2120	2724	213
2000	1300	2600	510	850	1700	2130	2822	257

Per capacità superiori a 1000 lt. rivolgersi all'ufficio commerciale
for items with capacity ove 1000 lt. refer to our sales department



I prodotti della serie 218 sono accumulatori per acqua refrigerata, idonei a funzionare come volani termici negli impianti di condizionamento. L'installazione di un 218 all'interno di un impianto di refrigerazione permette di aumentare il volume d'acqua complessivo dell'impianto, risolvendo il problema di inerzia frigorifera complessiva e permettendo condizioni ideali di funzionamento dei gruppi frigoriferi. Si riducono inoltre il numero di avviamenti della macchina aumentandone il ciclo di vita.



The 218 series products are storage tanks for chilled water, suitable for operation as buffer tanks in air-conditioning. Installing a 218 tank in a cooling system increases the total volume of water in the installation. This solves the problem of overall cooling inertia, ensuring ideal operating conditions for the chillers. Moreover, the number of unit start-ups is reduced, thus extending operating life.

CARATTERISTICHE TECNICHE <i>TECHNICAL FEATURES</i>	
Costruzione accumulo <i>Storage tank construction</i>	Acciaio al carbonio di elevata qualità <i>High quality carbon steel</i>
Trattamento interno / esterno <i>Inside / external treatment</i>	218 Zincatura a bagno caldo <i>Hot dip galvanization</i>
	218 G Grezzo <i>Raw</i>
Isolamento <i>Insulated</i>	EXTRA 100÷1000 lt. Poliuretano rigido iniettato, spessore 25 mm 1500÷5000 lt. Anticondensa - Polistirolo rigido, spessore 60 mm <i>100÷1000 lt. Injected rigid polyurethane, 25 mm thick</i> <i>1500÷5000 lt. Anti-condensate insulation - Rigid polystyrene, 60 mm thick</i>
Rivestimento esterno <i>Outside covering</i>	EXTRA 100÷1000 lt. Lamierino zincato verniciato, piedini ABS 1500÷5000 lt. Lamierino di alluminio gofrato <i>100÷1000 lt. Painted galvanised sheet metal, plastic feet</i> <i>1500÷5000 lt. Embossed aluminium plate</i>
Accumulo <i>Storage tank</i>	Pmax 6 bar - Tmax -10°C +60°C
Accessori di serie <i>Standard accessories</i>	1500÷5000 lt. Gruppo di scarico <i>1500÷5000 lt. Drain assembly</i>
Garanzia <i>Warranty</i>	2 anni <i>2 years</i>



COME SCEGLIERE L'ACCUMULATORE

Premesso che la scelta dell'accumulatore dipende da un insieme di variabili come: tipo di impianto, potenzialità del gruppo refrigeratore, contenuto d'acqua dell'evaporatore e delle batterie ecc.

La frequenza delle commutazioni di funzione dipende dalla massa d'acqua contenuta dall'impianto e dal differenziale di temperatura dei singoli gradini di parzializzazione del termostato.

Proponiamo pertanto tre criteri di massima per la scelta dell'accumulatore:

Ponendo: V = Volume dell'accumulatore
 N = Numero di gradini di parzializzazione
 P = Potenza frigorifera in frigorie/ora
DT on-off = Differenziale termostato regolazione

1) Calcolo per un sistema con massimo 8 gradini di parzializzazione:

$$V = P / (24 \times N \times \text{DT on-off}) \pm 10\%$$

2) Calcolo per un sistema con più di 8 gradini di parzializzazione:

$$V = P / (60 \times \text{DT on-off}) \pm 10\%$$

3) Calcolo in proporzione alla potenza dell'impianto:

$V = 24$ litri ogni KW per impianti on-off

$V = 12$ litri ogni KW per impianti a 2 gradini di parzializzazione

$V = 8$ litri ogni KW per impianti a 4 gradini di parzializzazione

HOW TO CHOOSE THE TANK

It first needs to be stressed that the choice of the storage tank depends on a series of variables, such as: type of system, chiller capacity, evaporator and coil water content etc.

The frequency of function switching cycles depends on the mass of water contained in the system and the temperature differential between the individual thermostat capacity control stages.

Consequently, three general criteria can be proposed for choosing the storage tank:

Where: V = Storage tank volume
 N = Number of capacity control stages
 P = Cooling capacity in frigories/hour
DT on-off = Control thermostat differential

1) Calculation for a system with maximum 8 capacity control stages:

$$V = P / (24 \times N \times \text{DT on-off}) \pm 10\%$$

2) Calculation for a system with more than 8 capacity control stages:

$$V = P / (60 \times \text{DT on-off}) \pm 10\%$$

3) Calculation in proportion to system capacity

$V = 24$ litres each kW for on-off systems

$V = 12$ litres each kW for systems with 2 capacity control stages

$V = 8$ litres each kW for systems with 4 capacity control stages

Esempio di impianto Example of a system

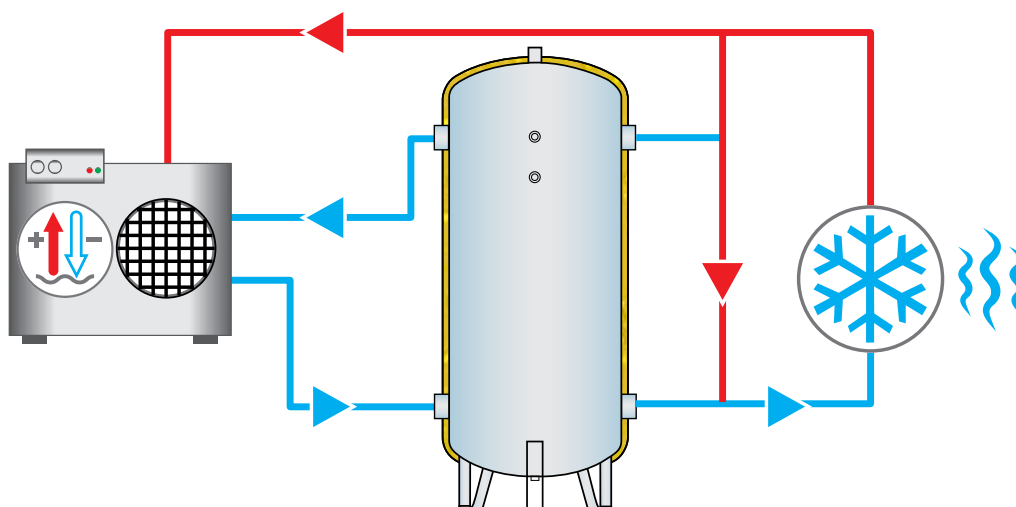



Disegno tecnico *Technical drawing*

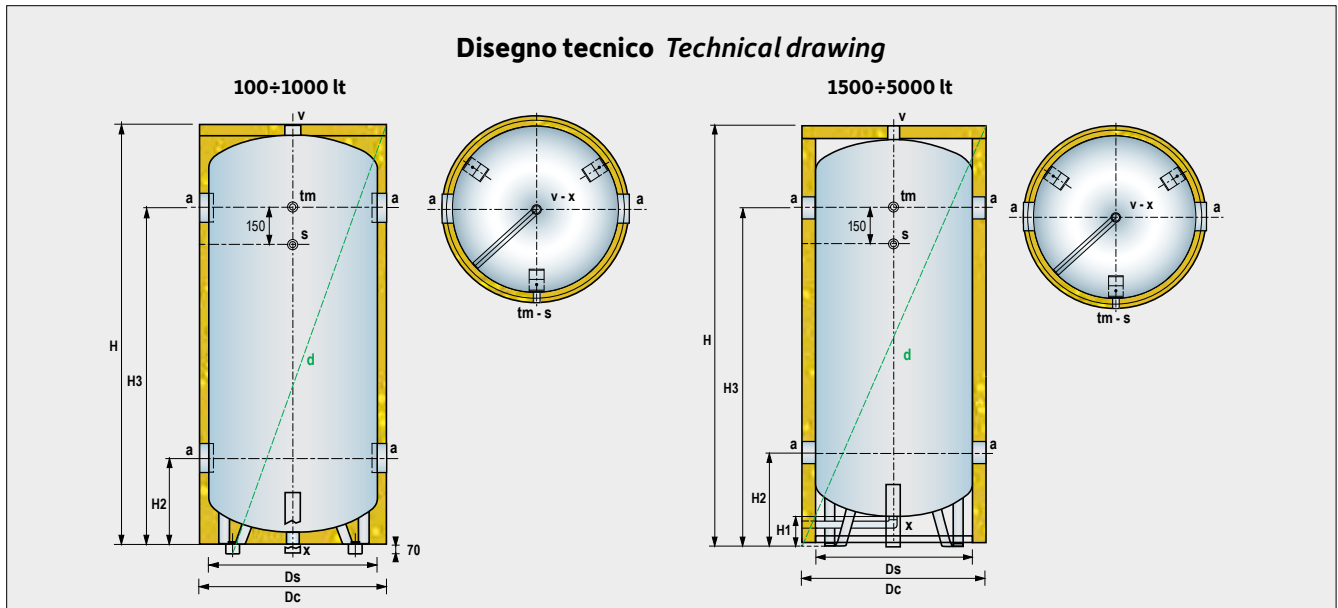

a-a	Ingresso / uscita acqua <i>Water inlet / outlet</i>	s	Attacco sonda <i>Probe fitting</i>	x	Scarico <i>Drain</i>
tm	Attacco termometro <i>Thermometer fitting</i>	v	Attacco valvola di sicurezza <i>Safety valve fitting</i>		

lt	CONNESSIONI CONNECTIONS				
	a-a	tm	s	v	x
100÷200	G2"-F	G1/2"-F	G1/2"-F	G1"1/4-F	G1"1/4-F
300÷1000	G3"-F	G1/2"-F	G1/2"-F	G1"1/4-F	G1"1/4-F
1500÷2000	G3"-F	G1/2"-F	G1/2"-F	G3"-F	G3"-F
3000÷5000	G4"-F	G1/2"-F	G1/2"-F	G3"-F	G3"-F

lt	DIMENSIONALE SIZES (mm)							Peso Weight (Kg)
	Ds	Dc	H	H1	H2	H3	d	
100	400	440	920	-	215	700	1056	22
200	450	500	1445	-	240	1200	1567	35
300	550	600	1385	-	265	1115	1546	44
500	650	700	1690	-	310	1380	1866	79
800	790	840	1755	-	340	1410	1982	111
1000	790	840	2005	-	340	1660	2211	129
1500	950	1070	2505	185	500	2120	2724	213
2000	1100	1220	2545	170	510	2130	2822	257
3000	1250	1370	2815	150	550	2340	3131	318
4000	1400	1520	2890	155	590	2380	3265	494
5000	1600	1720	2940	130	605	2395	3406	578

Uso: raffreddamento
Use: cooling

Abbinabile con:
Combined with:



218 EXTRA

ZINCATURA A BAGNO CALDO
HOT DIP GALVANISATION

	Codice Code	€
100	218EXTRA0100	
200	218EXTRA0200	
300	218EXTRA0300	
500	218EXTRA0500	
800	218EXTRA0800	
1000	218EXTRA1000	
1500	218EXTRA1500	
2000	218EXTRA2000	
3000	218EXTRA3000	
4000	218EXTRA4000	
5000	218EXTRA5000	

218G EXTRA

GREZZO
RAW

	Codice Code	€
100	218GEXTRA0100	
200	218GEXTRA0200	
300	218GEXTRA0300	
500	218GEXTRA0500	
800	218GEXTRA0800	
1000	218GEXTRA1000	
1500	218GEXTRA1500	
2000	218GEXTRA2000	
3000	218GEXTRA3000	
4000	218GEXTRA4000	
5000	218GEXTRA5000	



NEW E-SPD
Control system
and panel



ING. EMILIANO GALANTINI
Studio componenti ed impianti tecnici



Il sistema 320 raggruppa l'esigenza di avere in un unico prodotto, un serbatoio di prima raccolta e una pompa di rilancio per mantenere in pressione l'acqua di rete in un impianto. È costituito da un serbatoio in pressione trattato internamente con Vitroflex (idoneo per uso alimentare secondo le direttive CE), da una pompa gestita da un Inverter e da un brevettato sistema di circuiti idraulici.



The sistema 320 satisfies the requirement to have a collection tank and a recirculation pump in a unique product, in order to maintain the mains water in a system pressurised. It is made up from a pressurised tank treated internally with Vitroflex (suitable for use with foodstuffs in compliance with the CE Directives), a pump managed by an inverter and a patented system of hydraulic circuits.

CARATTERISTICHE TECNICHE TECHNICAL FEATURES

Costruzione accumulo Storage tank construction	Acciaio al carbonio di elevata qualità High quality carbon steel
Trattamento interno/esterno Inside/outside treatment	Trattamento interno anticorrosivo VITROFLEX idoneo per acqua uso alimentare secondo le direttive CE, D.M. 174 Trattamento esterno verniciatura RAL 5015 Inside treatment VITROFLEX corrosion-proofing suitable for drinking water in accordance with EC directives Outside treatment painted RAL 5015
Isolamento Insulated	Optional: Poliuretano flessibile, spessore 50 mm Optional: Flexible polyurethane, 50 mm thick
Pompa Pump	Particolarmente adatte a movimentare acqua potabile con temperatura fino a 40 °C, motori ad inverter con grado di protezione IP55 Suitable for handling drinking water with temperatures up to 40°C, inverter driven motors with IP55 index of protection
Rivestimento esterno Outside covering	Optional: PVC accoppiato Optional: Laminated PVC
Accumulo Storage tank	Pmax 6 bar - Tmax 90°C
Accessori di serie Standard accessories	Completo di tutto per la messa in servizio Ready plug and play
Garanzia Warranty	3 anni 3 years

Esempio di impianto Example of a system

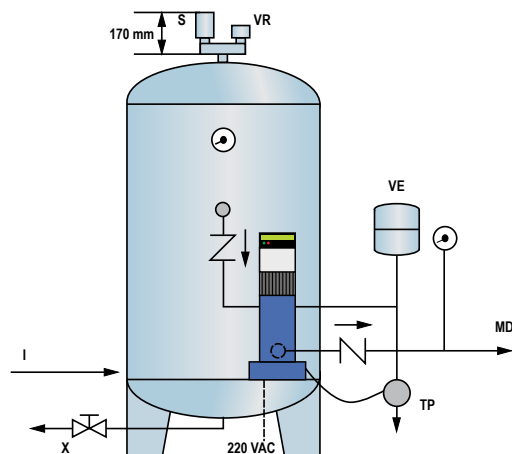

S	Valvola sfiato automatico Vent. valve
VR	Valvola rompivuoto Vacuum breaker
VE	Vaso di espansione Expansion
MD	Mandata alla distribuzione Water outlet
TP	Trasduttore di pressione Pressure control
X	Scarico Drain
I	Ingresso acquedotto Water supply

Prodotti conformi alla direttiva 2014/68/UE PED (Art.4 Par.3)

Products complying with the directive 2014/68/UE PED (Art.4 Par.3)

SVANTAGGI DEGLI IMPIANTI TRADIZIONALI

Negli impianti tradizionali, per il rilancio di acqua potabile, si usa un serbatoio di prima raccolta (solitamente in polietilene a pressione atmosferica) ed un gruppo pompe per il rilancio dell'acqua in pressione. Questo sistema ha tre svantaggi significativi:

1. Il serbatoio di prima raccolta atmosferico, perde la pressione della rete idrica a cui esso è collegato non riuscendo ad accumulare acqua in pressione.
2. Quando il sistema è fermo o viene interrotto da un bypass, l'acqua all'interno del serbatoio ristagna, favorendo l'evaporizzazione del cloro ed aumentando significativamente le probabilità di contaminazione batterica (LEGIONELLA).
3. Il sistema tradizionale necessita di spazio per il montaggio del serbatoio, delle pompe, dei collegamenti idraulici e di molta manodopera per l'installazione.

FUNZIONAMENTO SISTEMA 320

Quando il serbatoio è vuoto l'acqua in pressione entra dalla rete idrica e l'aria presente viene espulsa dalla valvola di sfiato automatico in testa. Quando il serbatoio è pieno il 320 diventa fisicamente un allargamento di tubo. Nel caso in cui la pressione di rete è sufficiente, il 320 resta fermo e l'acqua fluisce alle utenze tramite il sistema di bypass. Qualora invece la pressione sia insufficiente, il 320 avvia il sistema inverter che somma la sua spinta a quella eventualmente disponibile dalla rete idrica. Se oltre ad una mancanza di pressione, si verifica una mancanza di portata in ingresso, il 320 integra prelevando acqua dal serbatoio e facendo entrare aria dalla valvola rompivuoto posta in testa. In nessun caso il serbatoio e la rete idrica vengono messi in depressione. Arrivati ad un livello minimo, 320 si blocca aspettando che la rete idrica ricostituisca il livello minimo.

VANTAGGI SISTEMA 320

1. Nessun spreco della pressione in entrata dalla rete idrica, in quanto viene accumulata nel serbatoio in pressione.
2. 320 si attiva solo quando ce n'è bisogno, evitando sprechi di corrente.
3. L'acqua non ristagna mai in quanto viene sempre rinnovata all'interno del serbatoio, evitando contaminazioni batteriche (ambiente buio, in pressione e trattato per uso alimentare).
4. Spazio di installazione ridotto, il sistema viene fornito già assemblato, pronto per la messa in servizio e richiede poca manodopera per l'installazione.

APPLICATION ADVANTAGES

For the recirculation of drinking water in traditional systems, a first collection tank is used (usually in polyethylene at atmospheric pressure) and a pump unit for the recirculation of pressurised water. This system has three significant disadvantages:

1. *The first rainwater collection tank loses the pressure of the mains water to which it is connected, not managing to store pressurised water.*
2. *When the system is at a standstill or interrupted by a by-pass, the water inside the tank stagnates, thus favouring the evaporation of the chlorine and greatly increasing the probability of bacterial contamination (LEGIONELLA).*
3. *The traditional system requires space for assembly of the tank, pumps and hydraulic connections and a great amount of labour for installation.*

SISTEMA 320 OPERATION

When the tank is empty, the pressurised water enters from the water mains and the air present is expelled from the automatic vent valve at the head. When the tank is full the 320 becomes physically a pipe enlargement. If the mains pressure is sufficient, the 320 remains at a standstill and the water flows to the utilities via the bypass system. Whenever the pressure is insufficient, the 320 starts the inverter system that adds its thrust to that available from the water mains. If there is a lack of inlet flow rate as well as a lack of pressure, the 320 integrates by withdrawing water from the tank and making air enter from the vacuum breaker at the head. In no case the tank and water mains are put into negative pressure conditions. On reaching a minimum level, the 320 blocks and waits for the water mains to restore the minimum level.

SISTEMA 320 ADVANTAGES

1. *No pressure waste on entry to the water network, as it is accumulated in the pressurised tank.*
2. *320 only activates when required, thus preventing waste of current.*
3. *The water never stagnates as it is always renewed inside the tank, thus preventing bacterial contamination (dark environment, pressurised and treated for use as food).*
4. *Small installation space; the system is supplied already assembled, ready for commissioning and requires very little labour for installation.*



Funzionamento Tandem Tandem operation

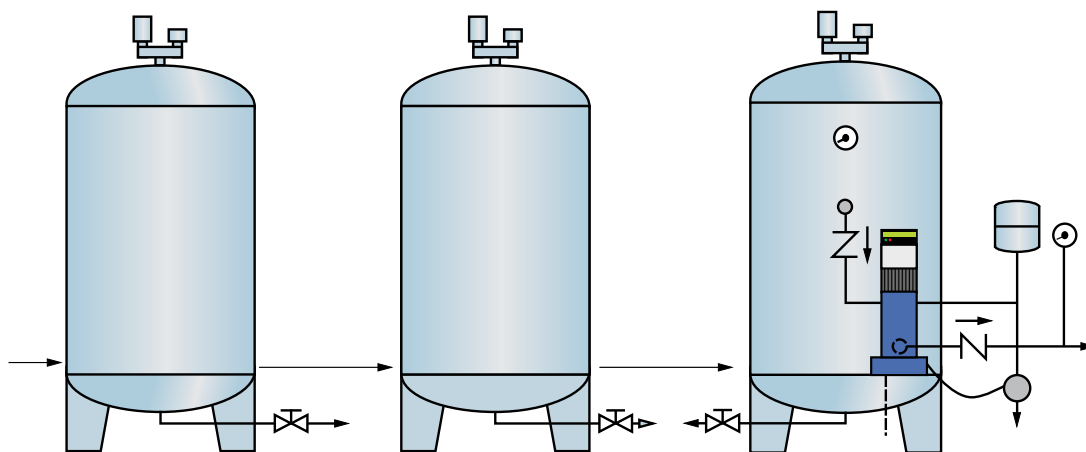

Quando i disservizi della rete idrica sono frequenti o lo spazio disponibile è insufficiente per installare un serbatoio di grande capacità, si possono aggiungere dei serbatoi privi di componentistica installata, tranne il gruppo valvole. Nella versione (TANDEM) i serbatoi hanno il gruppo di valvole in testa e sono collegati in serie per aumentare il volume di acqua disponibile. Il sistema inverter gestisce anche più pompe.

When disruptions of the water mains are frequent or the space available is insufficient to install a large tank, tanks can be added without installed components, except for the valves unit. (TANDEM) version are valves connected in series to increase the volume of water available. The inverter system also manages several pumps.



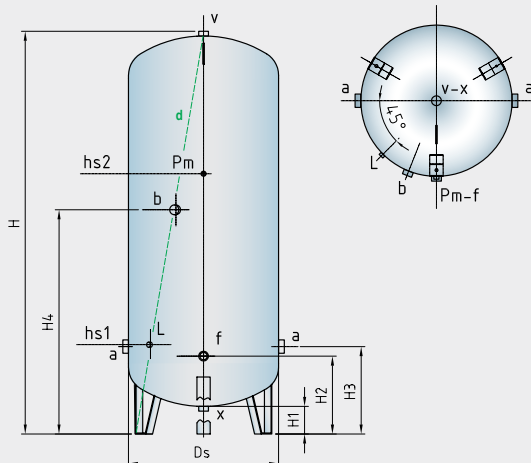

Disegno tecnico Technical drawing





a	Alimentazione acqua Water supply
b	Attacco by-pass idrico Water by-pass fitting
L	Attacco controllo di livello Level controller fitting
Pm	Attacco manometro Pressure gauge fitting
V	Attacco valvola di sfianto e rompivuoto Vent valve and vacuum breaker fitting
x	Scarico Drain
f	Accoppiamento pompa Pump coupling

lt	CONNESSIONI CONNECTIONS						
	a	b	L	Pm	V	x	f
300+2000	G2"-F	G1"1/4-F	G1/2"-F	G1/2"-F	G1"1/4-F	G1"1/4-F	G1"1/4-F

lt	DIMENSIONALE SIZES (mm)									Peso Weight (Kg)
	Ds	H	H1	H2	H3	H4	Sonde Probes		d	
							hs1	hs2		
300	550	1540	165	370	420	1140	430	1180	1565	55
500	650	1840	155	387	437	1157	447	1347	1869	82
800	790	1895	145	410	460	1180	470	1370	1936	105
1000	790	2150	145	410	460	1180	470	1370	2186	126
2000	1100	2510	190	460	510	1230	520	1600	2570	238

PRESTAZIONI PERFORMANCE				
Mod.	 KW inverter	 HP inverter	 l/m	 m.c.a.
320... 0.75	0.75	1	20	57,5
			40	49,5
			60	36,6
			80	19,5
320... 0.9	0.9	1.2	20	69
			40	59,5
			60	44
			80	23,4
320... 1.1	1.1	1.5	30	60
			60	50
			80	45
			100	35
			120	25
320... 1.5	1.5	2	30	74
			40	72
			60	65,5
			80	56
			100	44,5
			120	30,6
320... 1.7	1.7	2.3	30	86
			40	84
			60	76,5
			80	65,5
			100	51,5
			120	35,7

 Potenza pompa inverter (kW)
Inverter-driven pump power (kW)

 Potenza pompa inverter (HP)
Inverter-driven pump power (HP)

 Portata (l/m)
Flow-rate (l/m)

 Prevalenza (m.c.a.)
Pressure head (mWC)

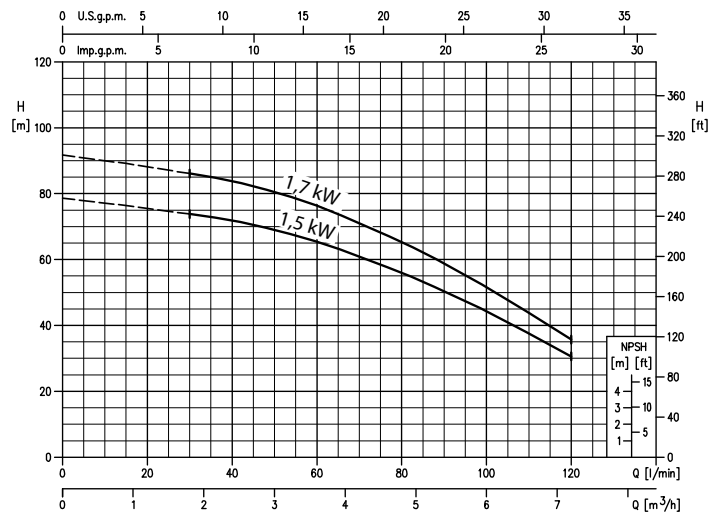
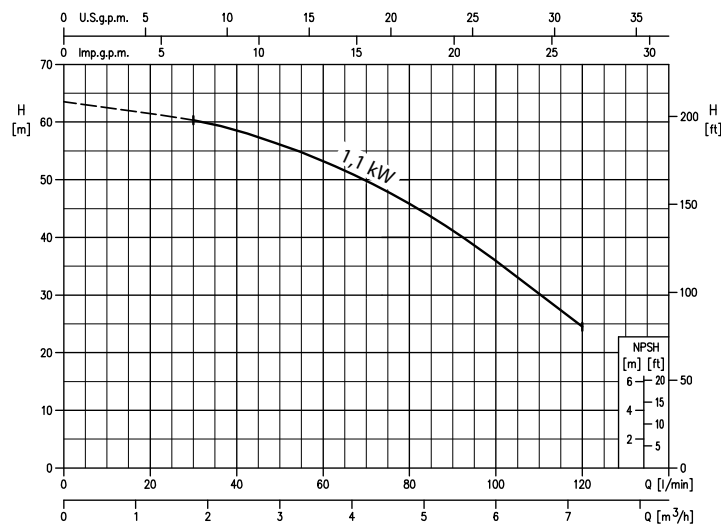
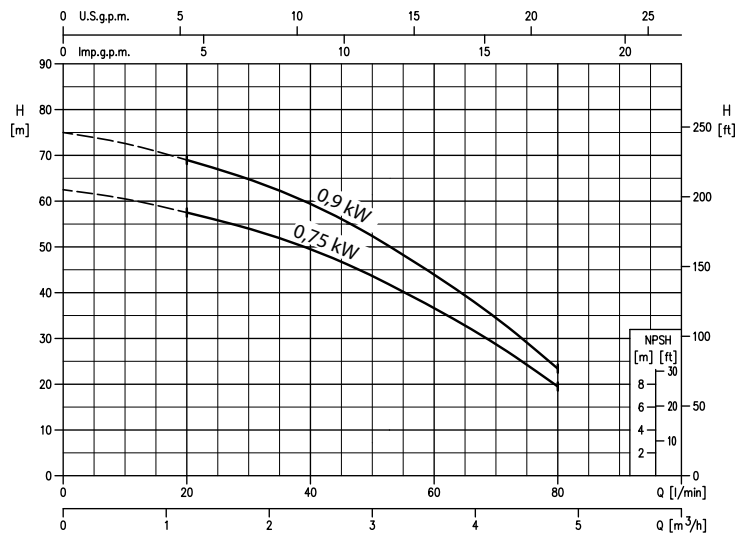

320 TANDEM VITROFLEX

Serbatoio con gruppo scarico e sicurezze
Storage tank with discharge system and security devices

lt	Codice Code	€
300	320T0300	
500	320T0500	
800	320T0800	
1000	320T1000	
2000	320T2000	

320 INVERTER KW 1.1 VITROFLEX

lt	Codice Code	€
300	320I0300/110	
500	320I0500/110	
800	320I0800/110	
1000	320I1000/110	
2000	320I2000/110	

320 INVERTER KW 0.75 VITROFLEX

lt	Codice Code	€
300	320I0300/075	
500	320I0500/075	
800	320I0800/075	
1000	320I1000/075	
2000	320I2000/075	

320 INVERTER KW 1.5 VITROFLEX

lt	Codice Code	€
300	320I0300/150	
500	320I0500/150	
800	320I0800/150	
1000	320I1000/150	
2000	320I2000/150	

320 INVERTER KW 0.9 VITROFLEX

lt	Codice Code	€
300	320I0300/090	
500	320I0500/090	
800	320I0800/090	
1000	320I1000/090	
2000	320I2000/090	

320 INVERTER KW 1.7 VITROFLEX

lt	Codice Code	€
300	320I0300/170	
500	320I0500/170	
800	320I0800/170	
1000	320I1000/170	
2000	320I2000/170	

Sistema doppia pompa disponibile su richiesta
Double pump System available on request

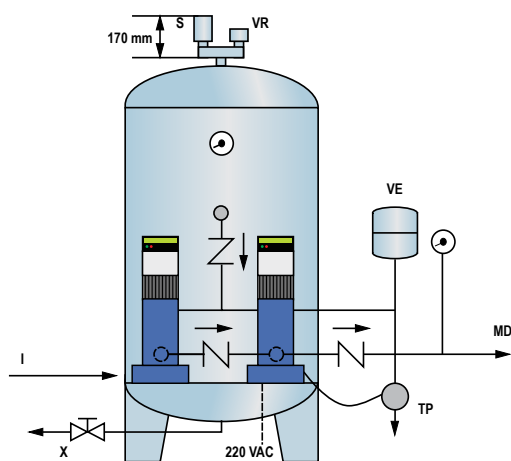

EXTRA PER SECONDA POMPA INVERTER

KW	Codice Code	€
0,75	POMPA075	
0,9	POMPA090	
1,1	POMPA110	
1,5	POMPA150	
1,7	POMPA170	



213 Serbatoi di prima raccolta in pressione

Pressurised primary collection tanks



I prodotti della serie 213 sono serbatoi idonei per l'accumulo di acqua in pressione e direttamente collegabili alla rete dell'acquedotto.



The 213 series products are suitable for the storage of pressurised water and can be connected directly to the mains supply.

CARATTERISTICHE TECNICHE TECHNICAL FEATURES

Costruzione accumulo Storage tank construction	Acciaio al carbonio di elevata qualità <i>High quality carbon steel</i>	
Trattamento interno/esterno Inside/outside treatment	213 P	Trattamento interno/esterno di zincatura a bagno caldo e trattamento interno anticorrosivo VITROFLEX idoneo per acqua uso alimentare secondo le direttive CE, D.M. 174 <i>Hot dip galvanisation on inside/outside and inside VITROFLEX corrosion-proofing suitable for drinking water in accordance with EC directives</i>
	213 Z	Trattamento interno/esterno di zincatura a bagno caldo <i>Hot dip galvanisation on inside/outside</i>
Isolamento Insulated	Optional: Anticondensa spessore 20mm <i>Optional: Anti-condensation 20mm thick</i>	
Rivestimento esterno Outside covering	Optional versione isolata: PVC accoppiato <i>Optional insulated version: Laminated PVC</i>	
Accumulo Storage tank	Pmax 6 bar - Tmax 50°C	
Garanzia Warranty	213 P	3 anni <i>3 years</i>
	213 Z	2 anni <i>2 years</i>

Esempio di schema PREAUTOCLAVE - AUTOCLAVE Example circuit PREAUTOCLAVE - AUTOCLAVE

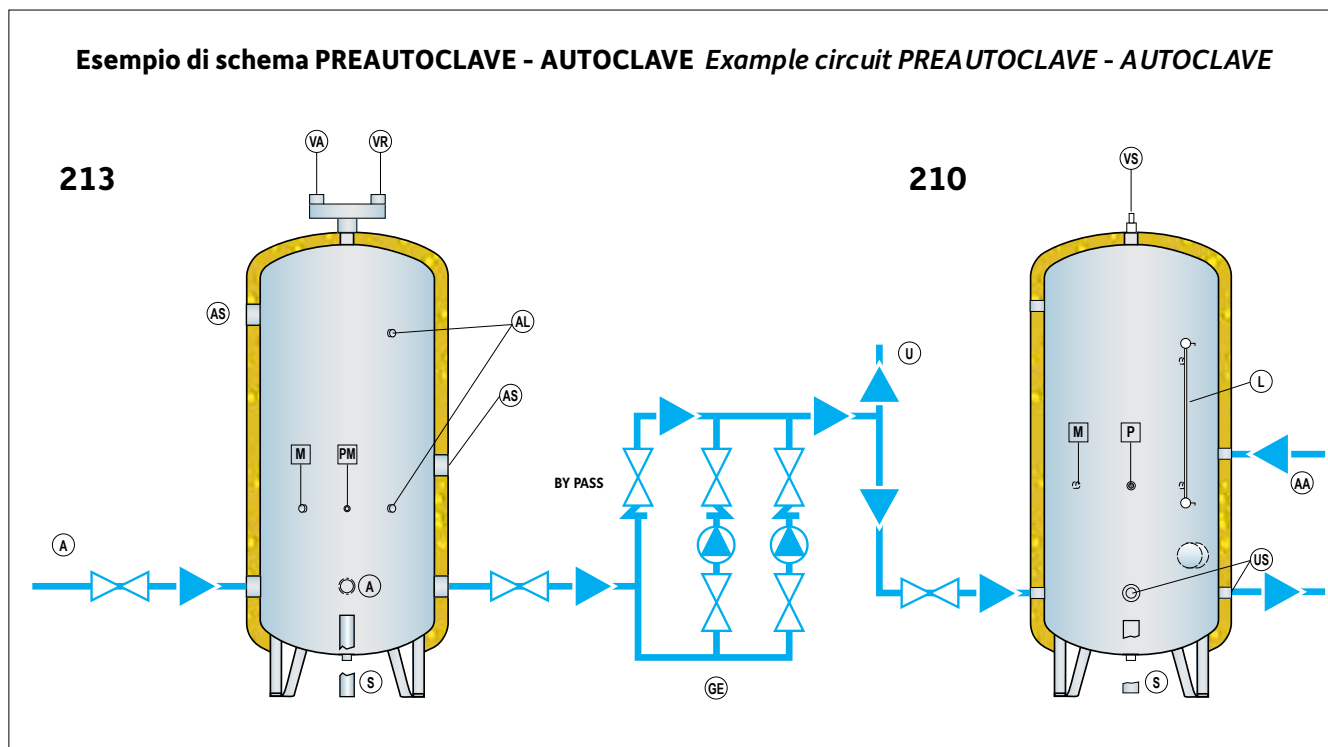

210	Autoclave Autoclave
213	Preautoclave Preautoclave
AL	Attacchi indicatore di livello Connection to level gauge
A	Entrate da acquedotto (utilizzo 1 o 2 attacchi) Inlet to waterworks (use of 1 or 2 connections)
AA	Alimentazione automatica aria Auto air power
AS	Attacchi di servizio Service connections

GE	Gruppo elettropompe Group elettropompe
L	Livello Level
M	Manometro Gauge
P	Pressostato Pressure
PM	Pressostato di minima Low pressure
S	Scarico Drain

U	Utenza Users
US	Utilizzi secondari Secondary uses
VA	Valvola sfiato aria automatica Automatic air vent valve
VR	Valvola rompivuto Vacuum breaker
VS	Valvola di sicurezza Safety valve



Disegno tecnico Technical drawing

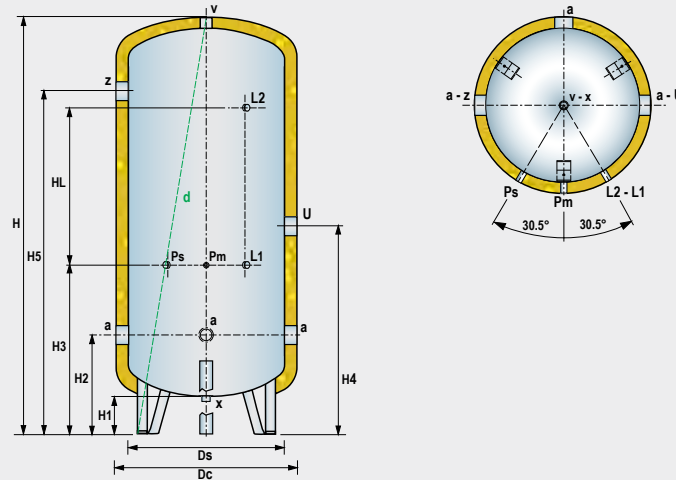

a	Ingresso / uscita acqua Water inlet / outlet	L1-L2	Attacco indicatore di livello Level gauge fitting	x	Scarico Drain
Pm	Attacco manometro Pressure gauge fitting	v	Attacco valvola rompivuoto / sfiato aria / di sicurezza Vacuum breaker / air vent / safety valve fitting	U	Servizio Service
Ps	Attacco termometro Thermometer fitting			z	Attacco ausiliario Auxiliary fitting

	CONNESSIONI CONNECTIONS							
	a	Pm	Ps	L1-L2	v	x	U	z
100-200	G1"-F	G1/2"-F	G1/2"-F	G1/2"-F	G1"1/4-F	G1"1/4-F	G1" 1/2-F	-
300	G1"1/2-F	G1/2"-F	G1/2"-F	G1/2"-F	G1"1/4-F	G1"1/4-F	G1" 1/2-F	-
500÷1000	G2"-F	G1/2"-F	G1/2"-F	G1/2"-F	G1"1/4-F	G1"1/4-F	G1" 1/2-F	-
1500	G2"-F	G1/2"-F	G1/2"-F	G1/2"-F	G1"1/4-F	G1"1/4-F	G1" 1/2-F	G1"1/2-F
2000	G2"1/2-F	G1/2"-F	G1/2"-F	G1/2"-F	G1"1/4-F	G1"1/4-F	G1" 1/2-F	G1"1/2-F
3000	G3"-F	G1/2"-F	G1/2"-F	G1/2"-F	G1"1/4-F	G1"1/4-F	G1" 1/2-F	G1"1/2-F
4000	G3"-F	G1/2"-F	G1/2"-F	G1/2"-F	G1"1/4-F	G1"1/4-F	G1" 1/2-F	G2"-F
5000	G4"-F	G1/2"-F	G1/2"-F	G1/2"-F	G1"1/4-F	G1"1/4-F	G1" 1/2-F	G2"-F

	DIMENSIONALE SIZES (mm)										Peso Weight (Kg)
	Ds	Dc	H	H1	H2	H3	H4	H5	HL	d	
100	400	440	1040	135	330	455	505	-	350	1070	23
200	450	490	1555	130	350	625	725	-	600	1579	40
300	550	590	1530	165	415	630	730	-	500	1564	48
500	650	690	1825	155	440	750	850	-	700	1863	85
800	790	830	1915	145	485	835	935	-	700	1966	109
1000	790	830	2165	145	485	895	995	-	800	2210	123
1500	950	990	2495	185	500	1010	1110	2070	800	2550	207
2000	1100	1140	2535	170	525	1020	1120	2070	800	2605	243
3000	1250	1290	2825	150	565	1145	1245	2345	1000	2905	335
4000	1400	1440	2830	155	635	1186	1285	2345	1000	2928	452
5000	1600	1640	2865	130	670	1200	1500	2360	1000	2989	540

213 Z

ZINCATURA A BAGNO CALDO
HOT DIP GALVANISATION

	Codice Code	€
100	213Z0100	
200	213Z0200	
300	213Z0300	
500	213Z0500	
800	213Z0800	
1000	213Z1000	
1500	213Z1500	
2000	213Z2000	
3000	213Z3000	
*4000	213Z4000	
*5000	213Z5000	

Anticondensa spessore 20 mm
Anti-condensation 20 mm thick

	Codice Code	€
100	213Z0100C	
200	213Z0200C	
300	213Z0300C	
500	213Z0500C	
800	213Z0800C	
1000	213Z1000C	
1500	213Z1500C	
2000	213Z2000C	
3000	213Z3000C	
*4000	213Z4000C	
*5000	213Z5000C	

213 P

ZINCATURA A BAGNO CALDO + VITROFLEX
HOT DIP GALVANISATION + VITROFLEX

	Codice Code	€
100	213P0100	
200	213P0200	
300	213P0300	
500	213P0500	
800	213P0800	
1000	213P1000	
1500	213P1500	
2000	213P2000	
3000	213P3000	
*4000	213P4000	
*5000	213P5000	

Anticondensa spessore 20 mm
Anti-condensation 20 mm thick

	Codice Code	€
100	213P0100C	
200	213P0200C	
300	213P0300C	
500	213P0500C	
800	213P0800C	
1000	213P1000C	
1500	213P1500C	
2000	213P2000C	
3000	213P3000C	
*4000	213P4000C	
*5000	213P5000C	

OPTIONAL

Descrizione Description	Codice Code	€
Kit valvola di sicurezza e valvola rompivuoto Safety valve and vacuum breaker valve kit	KITSIC213	
Passo d'uomo Man hole 300x400 1500÷10000 lt		

* Comprensivo di apertura di ispezione 300x400

* Equiped with inspection opening 300x400



I prodotti della serie 210 sono serbatoi per montaliquidi collaudati 2014/68/UE PED idonei per impianti di sollevamento e distribuzione dell'acqua in pressione. I serbatoi 210 sono disponibili nella versione non coibentato (nudo) o coibentato. Le Pressioni massime/Temperature massime di esercizio sono riportate nella tabella "Accumulo".



The 210 series products are surge tanks tested in compliance with 2014/68/UE PED suitable for pressurised water lifting and distribution systems. The 210 tanks are available in uninsulated and versions. The maximum operating pressure/temperature values are shown in the table on "Storage tank".

CARATTERISTICHE TECNICHE TECHNICAL FEATURES

Costruzione accumulo Storage tank construction	Acciaio al carbonio di elevata qualità High quality carbon steel	
Trattamento interno/esterno Inside/outside treatment	210 P	Trattamento interno/esterno di zincatura a bagno caldo e trattamento interno anticorrosivo VITROFLEX idoneo per acqua uso alimentare secondo le direttive CE, D.M. 174 Hot dip galvanisation on inside/outside and inside VITROFLEX corrosion-proofing suitable for drinking water in accordance with EC directives
	210 Z	Trattamento interno/esterno di zincatura a bagno caldo Hot dip galvanisation on inside/outside
Isolamento Insulated	Optional: Anticondensa spessore 20mm Optional: Anti-condensation 20mm thick	
Rivestimento esterno Outside covering	Optional versione isolata: PVC accoppiato Optional insulated version: Laminated PVC	
Accumulo Storage tank	Pmax 8 bar Tmin -10°C Tmax 50°C Pmax 11,5 bar Tmin -10°C Tmax 50°C	
Garanzia Warranty	210 P	3 anni 3 years
	210 Z	2 anni 2 years

Esempio di schema PREAUTOCLAVE - AUTOCLAVE Example circuit PREAUTOCLAVE - AUTOCLAVE

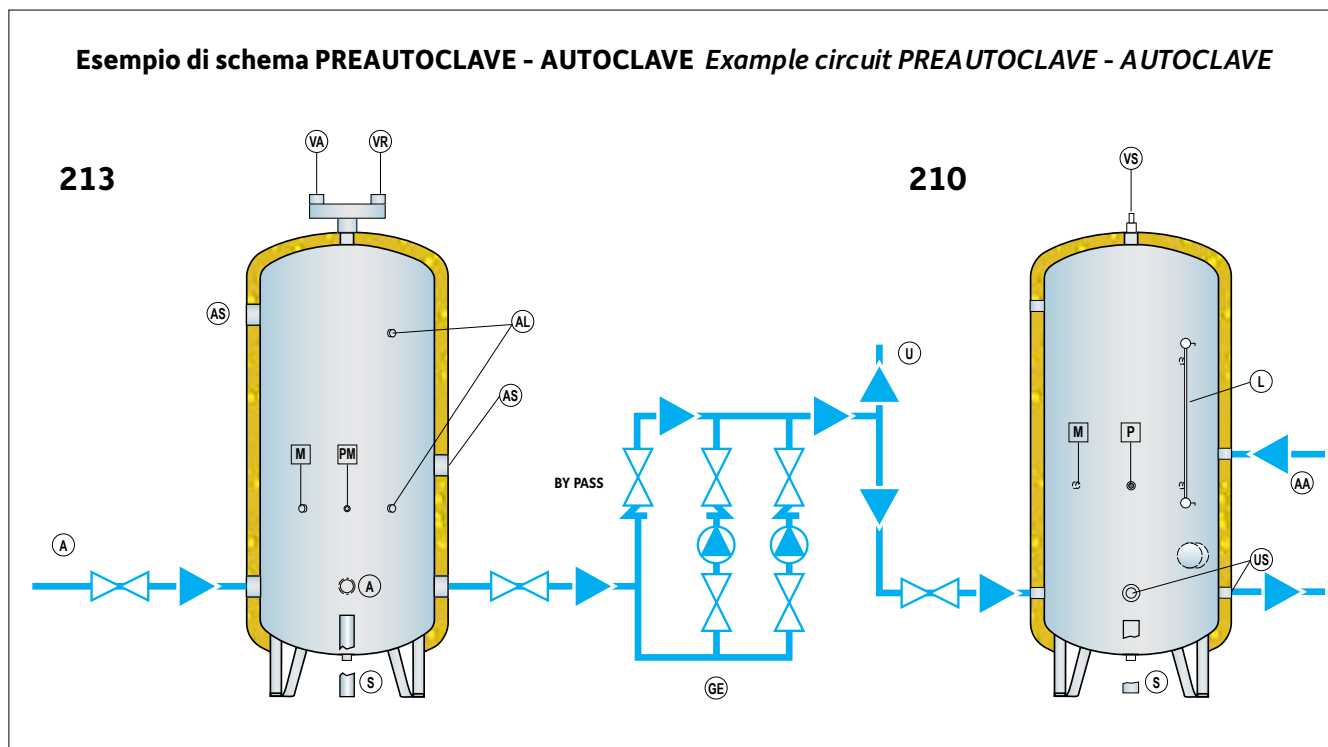

210	Autoclave Autoclave
213	Preautoclave Preautoclave
AL	Attacchi indicatore di livello Connection to level gauge
A	Entrate da acquedotto (utilizzo 1 o 2 attacchi) Inlet to waterworks (use of 1 or 2 connections)
AA	Alimentazione automatica aria Auto air power
AS	Attacchi di servizio Service connections

GE	Gruppo elettropompe Group elettropompe
L	Livello Level
M	Manometro Gauge
P	Pressostato Pressure
PM	Pressostato di minima Low pressure
S	Scarico Drain

U	Utenza Users
US	Utilizzi secondari Secondary uses
VA	Valvola sfiato aria automatica Automatic air vent valve
VR	Valvola rompivuto Vacuum breaker
VS	Valvola di sicurezza Safety valve



Disegno tecnico Technical drawing

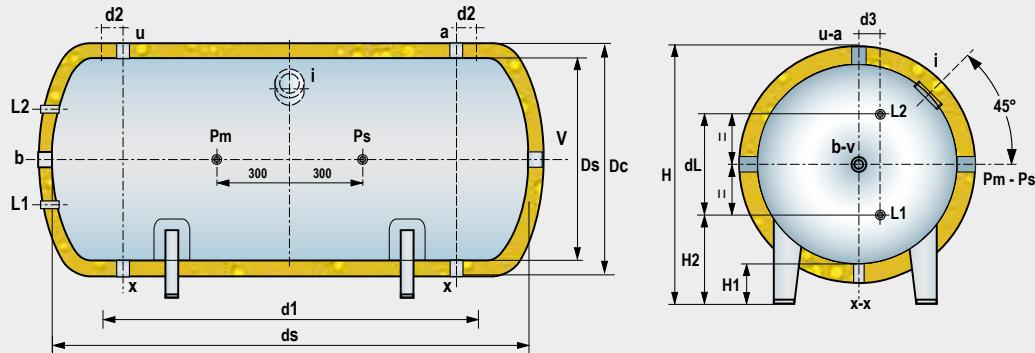

a	Ingresso acqua Water inlet	Pm	Attacco manometro Pressure gauge fitting	V	Attacco valvola di sicurezza Safety valve fitting
b	Alimentazione aria Air supply	Ps	Attacco pressostato Pressure switch fitting	x	Scarico Drain
u	Utilizzo Demand	L1-L2	Attacco indicatore di livello Level gauge fitting	i	Apertura d'ispezione (solo su richiesta) Inspection opening (only upon request)

lt	CONNESSIONI CONNECTIONS										
	a	b		u	z	Pm	Ps	L1-L2	V	x	
		Pos. vert. Vert. inst.	Pos. orizz. Horiz. inst.							Pos. vert. Vert. inst.	Pos. orizz. Horiz. inst.
300÷1000	tab.	G1"1/4-F	G1"1/4-F	-	-	G1/2"-F	G1/2"-F	G1/2"-F	G1"1/4-F	G1"1/4-F	NA
1500÷2000	tab.	G1"1/4-F	G1"1/4-F	-	tab.	G1/2"-F	G1/2"-F	G1/2"-F	G1"1/4-F	G1"1/4-F	tab.
3000÷10000	tab.	G1"1/2-F	G1"1/4-F	tab.	tab.	G1/2"-F	G1/2"-F	G1/2"-F	G1"1/4-F	G1"1/4-F	tab.

lt	DIMENSIONALE SIZES (mm)										Conneessioni Connections		Peso Weight (Kg)
	Ds	Dc	H	H1	H2	ds	d1	d2	d3	dL	a-u	x	
210 orizzontale horizontal - 8 bar													
1500	1000	1040	1170	170	430	2120	1500	90	50	480	G2"-F	G2"-F	200
2000	1000	1040	1165	165	395	2605	2000	105	130	540	G2"1/2-F	G2"1/2-F	340
3000	1200	1240	1335	135	435	2745	2000	120	60	600	G3"-F	G3"-F	480
4000	1450	1490	1620	170	525	2840	2000	160	60	740	G4"-F	G4"-F	630
5000	1450	1490	1620	170	525	3340	2500	160	60	740	G4"-F	G4"-F	725
6000	1450	1490	1620	170	525	3840	3000	160	60	740	G4"-F	G4"-F	815
8000	1650	1690	1795	145	530	3920	3000	160	60	880	G4"-F	G4"-F	1160
10000	1650	1690	1795	145	530	4920	4000	160	60	880	G4"-F	G4"-F	1400
210 orizzontale horizontal - 11.5 bar													
2000	1000	1040	1165	165	395	2615	2000	130	60	540	G2"1/2-F	G2"1/2-F	390
3000	1200	1240	1335	135	435	2745	2000	150	60	600	G3"-F	G3"-F	590
4000	1450	1490	1620	170	525	2875	2000	170	60	740	G4"-F	G4"-F	880
5000	1450	1490	1620	170	525	3380	2500	180	60	740	G4"-F	G4"-F	1017
6000	1450	1490	1620	170	525	3900	3000	180	60	740	G4"-F	G4"-F	1152
8000	1650	1690	1795	145	530	4000	3000	190	60	880	G4"-F	G4"-F	1470
10000	1650	1690	1795	145	530	5005	4000	190	60	880	G4"-F	G4"-F	1840

Disegno tecnico *Technical drawing*

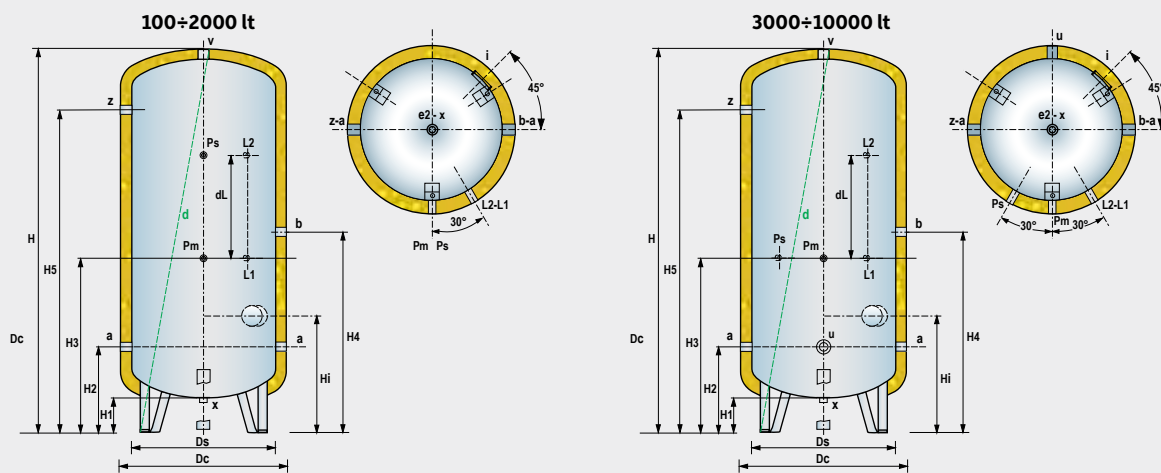

a	Ingresso / uscita acqua <i>Water inlet / outlet</i>	Pm	Attacco manometro <i>Pressure gauge fitting</i>	V	Attacco valvola di sicurezza <i>Safety valve fitting</i>
b	Alimentazione aria <i>Air supply</i>	Ps	Attacco pressostato <i>Pressure switch fitting</i>	x	Scarico <i>Drain</i>
u	Utilizzo <i>Demand</i>	L1-L2	Attacco indicatore di livello <i>Level gauge fitting</i>	I	Apertura d'ispezione (solo su richiesta) <i>Inspection opening (only upon request)</i>
z	Attacco ausiliario <i>Auxiliary fitting</i>				

	DIMENSIONALE SIZES (mm)											Connessioni <i>Connections</i>		Peso Weight (Kg)
	Ds	Dc	H	H1	H2	H3	H4	H5	Hi	dL	d	a-u	z	
210 verticale vertical - 8 bar														
300	550	590	1496	130	373	588	800	-	588	500	1531	G1 1/2"-F	-	70
500	650	690	1805	120	400	710	920	-	610	700	1844	G2"-F	-	105
800	790	830	1900	130	475	825	1030	-	685	700	1951	G2"-F	-	136
1000	790	830	2148	130	475	885	1115	-	725	800	2194	G2"-F	-	162
1500	1000	1040	2333	178	565	1075	1275	1875	775	800	2397	G2"-F	G1 1/2"-F	190
2000	1000	1040	2830	183	580	1075	1290	2375	1025	800	2883	G2 1/2"-F	G1 1/2"-F	330
3000	1200	1240	2980	197	677	1257	1357	2457	1067	1000	3050	G3"-F	G1 1/2"-F	470
4000	1450	1490	3066	180	740	1290	1390	2450	1000	1000	3162	G3"-F	G2"-F	620
5000	1450	1490	3566	180	760	1490	1590	2950	1000	1250	3649	G4"-F	G2"-F	715
6000	1450	1490	4066	180	760	1690	1790	3440	1000	1250	4139	G4"-F	G2 1/2"-F	805
8000	1650	1690	4140	145	760	1700	1800	3460	1000	1250	4231	G4"-F	G2 1/2"-F	1150
10000	1650	1690	5150	145	760	2100	2200	4460	1000	1250	5224	G4"-F	G2 1/2"-F	1390
210 verticale vertical - 11.5 bar														
1000	790	830	2279	130	460	860	1115	-	725	800	2322	G2"-F	-	220
2000	1000	1040	2830	180	620	1100	1290	2355	840	800	2883	G2 1/2"-F	G1 1/2"-F	380
3000	1200	1240	2994	182	707	1257	1357	2427	1057	1000	3064	G3"-F	G1 1/2"-F	580
4000	1450	1490	3098	180	780	1310	1410	2440	1000	1000	3193	G3"-F	G2"-F	870
5000	1450	1490	3598	180	795	1505	1605	2940	1000	1250	3681	G4"-F	G2"-F	1007
6000	1450	1490	4115	180	800	1700	1800	3440	1000	1250	4187	G4"-F	G2 1/2"-F	1142
8000	1650	1690	4170	145	825	1700	1800	3440	1000	1250	4261	G4"-F	G2 1/2"-F	1460
10000	1650	1690	5170	145	825	2100	2200	4440	1000	1250	5244	G4"-F	G2 1/2"-F	1830

Per versioni zincate da 4000 lt. a 10000 lt. obbligatorio passo d'uomo
Per versioni zincate da 4000 lt. a 10000 lt. obbligatorio passo d'uomo



210 Z

 ZINCATURA A BAGNO CALDO
 HOT DIP GALVANISATION

	Codice Code	bar	€
300	AZ00300/08	8	
500	AZ00500/08		
800	AZ00800/08		
1000	AZ01000/08		
1500	AZ01500/08		
2000	AZ02000/08		
3000	AZ03000/08		
*4000	AZ04000/08		
*5000	AZ05000/08		
*6000	AZ06000/08		
*8000	AZ08000/08		
*10000	AZ10000/08		
1000	AZ01000/115		11,5
2000	AZ02000/115		
3000	AZ03000/115		
*4000	AZ04000/115		
*5000	AZ05000/115		
*6000	AZ06000/115		
*8000	AZ08000/115		
*10000	AZ10000/115		

 Anticondensa spessore 20 mm
 Anti-condensation 20 mm thick

	Codice Code	bar	€
1000	AZ01000/115C	11,5	
2000	AZ02000/115C		
3000	AZ03000/115C		
*4000	AZ04000/115C		
*5000	AZ05000/115C		
*6000	AZ06000/115C		
*8000	AZ08000/115C		
*10000	AZ10000/115C		

OPTIONAL

Descrizione Description	€
Passamano Hand hole 100x150 300÷1000 lt	
Passo d'uomo Man hole 300x400 1500÷10000 lt	
Maggiorazione versione orizzontale Extra price for horizontal version 1000÷3000 lt	
Maggiorazione versione orizzontale Extra price for horizontal version 4000÷5000 lt	
Maggiorazione versione orizzontale Extra price for horizontal version 6000÷10000 lt	

* Comprensivo di apertura d'ispezione 300x400.

* Equiped with inspection opening 300x400

210 P

ZINCATURA A BAGNO CALDO + VITROFLEX
HOT DIP GALVANISATION + VITROFLEX

 lt	Codice Code	bar	€	
300	AP00300/08	8		
500	AP00500/08			
800	AP00800/08			
1000	AP01000/08			
1500	AP01500/08			
2000	AP02000/08			
3000	AP03000/08			
*4000	AP04000/08			
*5000	AP05000/08			
*6000	AP06000/08			
*8000	AP08000/08			
*10000	AP10000/08			
1000	AP01000/115		11,5	
2000	AP02000/115			
3000	AP03000/115			
*4000	AP04000/115			
*5000	AP05000/115			
*6000	AP06000/115			
*8000	AP08000/115			
*10000	AP10000/115			

Anticondensa spessore 20 mm
Anti-condensation 20 mm thick

 lt	Codice Code	bar	€
1000	AP01000/115C	11,5	
2000	AP02000/115C		
3000	AP03000/115C		
*4000	AP04000/115C		
*5000	AP05000/115C		
*6000	AP06000/115C		
*8000	AP08000/115C		
*10000	AP10000/115C		

OPTIONAL

Descrizione Description	€
Passamano Hand hole 100x150 300÷1000 lt	
Passo d'uomo Man hole 300x400 1500÷10000 lt	
Maggiorazione versione orizzontale Extra price for horizontal version 1000÷3000 lt	
Maggiorazione versione orizzontale Extra price for horizontal version 4000÷5000 lt	
Maggiorazione versione orizzontale Extra price for horizontal version 6000÷10000 lt	

* Comprensivo di apertura d'ispezione 300x400.

* Equiped with inspection opening 300x400



I prodotti della serie EVPX INOX sono bollitori per la produzione e l'accumulo di acqua calda sanitaria realizzati in acciaio inox AISI 316 L.

Gli scambiatori di calore sono a fascio tubiero estraibile, con tubi in acciaio inossidabile mandrinati su piastra in acciaio. Una grande potenzialità di scambio unita a perdite di carico trascurabili li rendono il compromesso ideale fra potenza installata e volume d'acqua calda accumulato, sono ideali per impianti sanitari ove il prelievo di acqua calda raggiunge punte di richiesta elevate (centri sportivi, ospedali, piscine, impianti civili centralizzati,...).



The EVPX INOX series products are storage tanks for the production and storage of domestic hot water made from AISI 316 L stainless steel. The heat exchangers used are removable U-shaped tube bundles.

These stand out for their high heat exchange capacity with low pressure drop. These storage tanks represent the best compromise between installed power and volume of hot water stored, making them ideal for connection to domestic hot water systems where delivery of hot water has very high peaks (sports centres, hospitals, swimming pools, centralised residential systems, etc.).

CARATTERISTICHE TECNICHE TECHNICAL FEATURES

Costruzione accumulo <i>Storage tank construction</i>	Acciaio inox AISI 316L <i>Stainless steel AISI 316L</i>
Isolamento <i>Insulated</i>	Poliuretano rigido iniettato, 300÷500 lt. spessore 50 mm <i>Injected rigid polyurethane, 300÷500 lt. 50 mm thick</i>
	ECOFIRE, rimovibile 800÷2000 lt. spessore 130 mm <i>ECOFIRE, removable 800÷2000 lt. 130 mm thick</i>
	ECOFIRE, rimovibile, 2500÷5000 lt. spessore 100 mm <i>ECOFIRE, removable, 2500÷5000 lt. 100 mm thick</i>
Rivestimento esterno <i>Outside covering</i>	PVC accoppiato <i>Laminated PVC</i>
Accumulo <i>Storage tank</i>	Pmax 6 bar - Tmax 95°C
Scambiatore <i>Heat exchanger</i>	Pmax 12 bar - Tmax 95°C
Accessori di serie <i>Standard accessories</i>	Anodo di magnesio <i>Magnesium anode</i>
Garanzia <i>Warranty</i>	5 anni - Anodo di magnesio <i>5 years - Magnesium anode</i>

EVPX

lt	Codice Code	€	Classe Energetica ErP
300	EVPXINOX0300C		C
500	EVPXINOX0500C		C
800	EVPXINOX0800C		C
1000	EVPXINOX1000C		C
1500	EVPXINOX1500C		C
2000	EVPXINOX2000C		C
2500	EVPXINOX2500C		C
3000	EVPXINOX3000C		C
4000	EVPXINOX4000C		C
5000	EVPXINOX5000C		C

Listino prezzi accessori e ricambi a pagina 116

Accessories and spare parts price list available at page 116

Prodotti conformi alla direttiva 2014/68/UE PED (Art.4 Par.3)

Products complying with the directive 2014/68/UE PED (Art.4 Par.3)

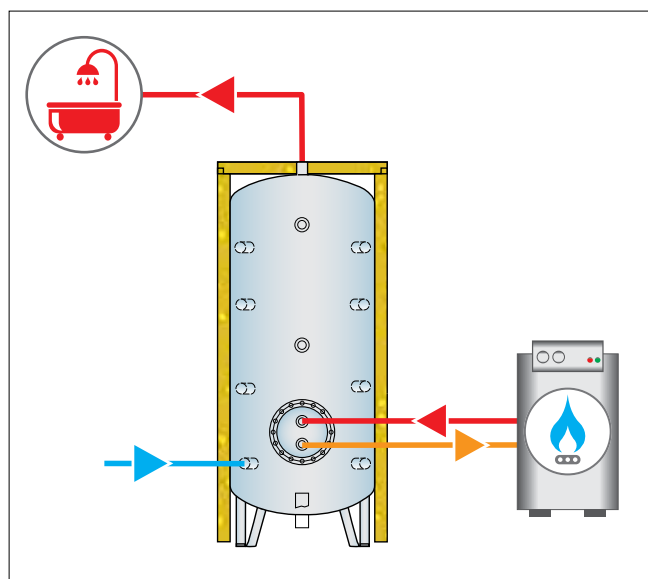



Disegno tecnico Technical drawing

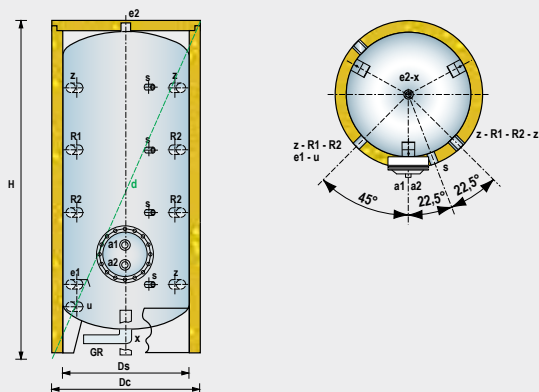

a1-a2	Entrata/uscita scambiatore esterno External heat exchanger inlet/outlet
e1	Entrata acqua sanitaria Domestic water inlet
e2	Uscita acqua sanitaria Primary circuit outlet
s	Attacco sonda Probe fitting
R1-R2	Attacco resistenza elettrica / ricircolo Electric heater fitting / recirculation
z	Servizio Service
u	Scarico / Servizio Drain / Service
x	Scarico Drain
GR	Gruppo di scarico Drain assembly

lt	CONNESSIONI CONNECTIONS								
	a1-a2	e1-e2	s	u	z	R1	R2	x	GR
300-500	G1"-F	G1"1/4-F	G 1/2"-F	G1"-F	G1"1/4-F	G1"1/2-F	G1"1/4-F	-	-
800-1000	G2"-F	G1"1/2-F	G 1/2"-F	G1"-F	G1"1/4-F	G1"1/2-F	G1"1/4-F	-	-
1500	G2"-F	G2"-F	G 1/2"-F	G1"-F	G1"1/4-F	G1"1/2-F	G1"1/4-F	-	-
2000-2500	G2"-F	G2"-F	G 1/2"-F	-	G1"1/4-F	G1"1/2-F	G1"1/4-F	-	G1"-F
3000÷5000	G2"-F	G3"-F	G 1/2"-F	-	G1"1/4-F	G1"1/2-F	G1"1/4-F	-	G1"-F

lt	DIMENSIONALE SIZES (mm)										
	Ds	H5	Dc	H4	H3	H	H1	H2	d	H6	kg
300	500	1080	600	595	215	1580	-	110	1690	1350	60
500	650	1105	750	615	240	1630	-	135	1794	1375	90
800	790	1145	1050	655	275	1815	-	170	2100	1410	140
1000	790	1355	1050	810	275	2160	-	170	2400	1755	160
1500	1000	1400	1260	765	340	2195	-	325	2530	1725	230
2000	1100	1515	1360	1070	475	2615	100	-	2948	1975	300
2500	1200	1600	1400	1040	505	2645	100	-	2995	2105	350
3000	1250	1730	1450	1100	515	2845	90	-	3195	2300	380
4000	1400	1185	1600	1190	595	2975	120	-	3380	2380	560
5000	1600	1185	1800	1185	600	3005	100	-	3505	2385	650

PRESTAZIONI PERFORMANCE				
lt	m ²	lt	KW	l/h
300	0.75	3,8	27	381
500	1	4,7	32	508
800	1.5	7,7	56	762
1000	2	9.5	74	1016
1500	3	13	94	1525
2000	4	17.2	150	2033
2500	5	20.8	174	2541
3000	6	24.8	200	3049
4000	8	31.4	289	4065
5000	10	34.3	336	5082

Prestazioni calcolate ipotizzando le temperature di ingresso/uscita circuito primario 80/70° C, secondario 10°/45° C ed una temperatura di accumulo di 60° C.
Performance calculated assuming a primary circuit inlet/outlet temperature of 80/70°C, secondary in/out 10°/45°C and a storage temperature of 60°C.



I prodotti della serie CAL INOX sono bollitori per la produzione e l'accumulo di acqua calda sanitaria realizzati in acciaio inox AISI 316 L. Le spire inferiori dello scambiatore arrivano fino alla parte più bassa del bollitore riscaldando così una maggiore quantità di acqua.



The CAL INOX series products are storage cylinders for the production and storage of domestic hot water made from AISI 316 L stainless steel. The bottom coil of the heat exchanger runs down to the bottom of the storage tank, thus heating a higher volume of water.

Tutti i serbatoi coibentati rispettano i requisiti richiesti dalle direttive 2009/125/CE e 2010/30/UE sull'efficienza energetica .
All the insulated tanks, comply with the directive 2009/125/CE and 2010/30UE about energy efficiency.

CARATTERISTICHE TECNICHE TECHNICAL FEATURES

Costruzione accumulo <i>Storage tank construction</i>	Acciaio inox AISI 316L <i>Stainless steel AISI 316L</i>
Isolamento <i>Insulated</i>	Poliuretano rigido iniettato, 200÷500 lt. spessore 50 mm <i>Injected rigid polyurethane, 200÷500 lt. 50 mm thick</i>
	ECOFIRE RIMOVIBILE, 800÷2000 lt. spessore 130 mm <i>ECOFIRE REMOVABLE, 800÷2000 lt. 130 mm thick</i>
Rivestimento esterno <i>Outside covering</i>	PVC accoppiato <i>Laminated PVC</i>
Accumulo <i>Storage tank</i>	Pmax 6 bar - Tmax 95°C
Scambiatore <i>Heat exchanger</i>	Pmax 12 bar - Tmax 95°C
Accessori di serie <i>Standard accessories</i>	Flangia d'ispezione - Anodo di magnesio <i>Inspection flange - Magnesium anode</i>
Garanzia <i>Warranty</i>	5 anni <i>5 years</i>

CALINOX

	Codice Code	€	Classe Energetica ErP
200	CALINOX0200C		C
300	CALINOX0300C		C
500	CALINOX0500C		C
800	CALINOX0800C		C
1000	CALINOX1000C		C
1500	CALINOX1500C		C
2000	CALINOX2000C		C

Listino prezzi accessori e ricambi a pagina 116

Accessories and spare parts price list available at page 116

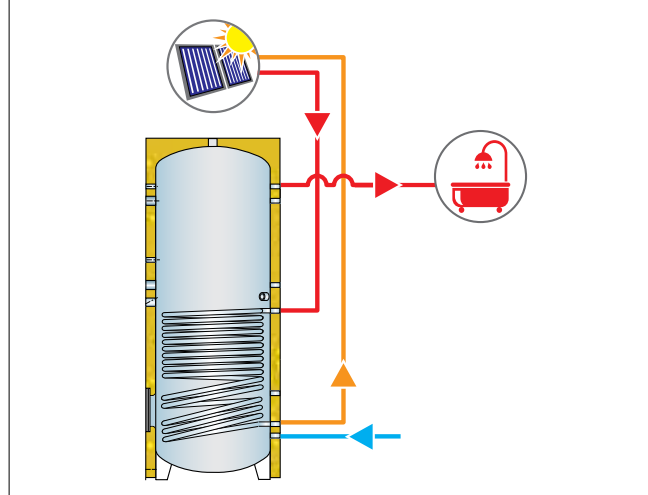
Esempio di impianto Example of a system

Uso: acqua calda sanitaria
Use: domestic hot water

Abbinabile con:
Combined with:



Disegno tecnico Technical drawing

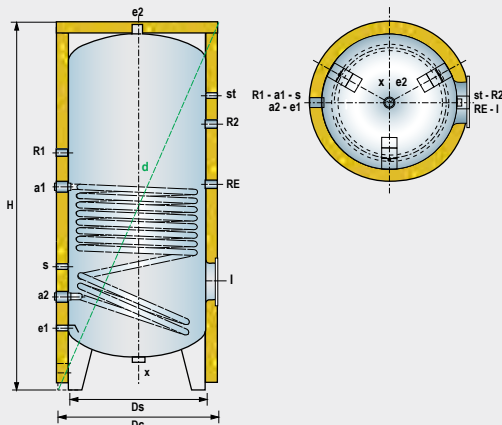

a1-a2	Entrata / uscita scambiatore Heat exchanger inlet / outlet
e1	Entrata acqua sanitaria / scarico Domestic water inlet / drain
e2	Uscita acqua sanitaria Primary circuit outlet
s	Attacco sonda Probe fitting
RE	Attacco resistenza elettrica / Ricircolo Electric heater fitting / Ricirculation
R1	Servizio Service
st	Attacco termometro Thermometer
x	Scarico Drain
I	Flangia d'ispezione Inspection flanges
R2	Anodo Anode

	CONNESSIONI CONNECTIONS								
	a1-a2	e1-e2	s	RE	R1	R2	st	x	I
200+500	G1"-F	G1"-F	G 1/2"-F	G1"1/2-F	G 1/2"-F	G1"1/4-F	G 1/2"-F	-	Øi120 Øe180
800-1000	G1"-F	G1"1/2-F	G 1/2"-F	G1"1/2-F	G1"-F	G1"1/4-F	G 1/2"-F	G1"-F	Øi120 Øe180
1500-2000	G1"-F	G2"-F	G 1/2"-F	G1"1/2-F	G1"-F	G1"1/4-F	G 1/2"-F	G1"-F	Øi220 Øe290

	DIMENSIONALE SIZES (mm)						
	Ds	Dc	H a2/a1	H	H RE/R1	d	kg
200	450	550	190/630	1290	690/840	1405	6
300	500	600	230/790	1580	845/1050	1690	80
500	650	750	240/840	1630	895/1095	1794	105
800	790	1050	275/870	1815	940/1200	2100	150
1000	790	1050	275/1020	2160	1090/1400	2400	170
1500	1000	1260	375/1120	2195	1180/1460	2530	250
2000	1100	1360	465/1350	2615	1420/1755	2948	330

PRESTAZIONI PERFORMANCE				
200	0.90	6.5	21,5	559
300	1.30	9.2	32,2	838
500	2.00	13.8	45,0	1175
800	2.70	19.0	56,0	1510
1000	3.00	6.5	64,4	1677
1500	3.70	26.3	79,4	2068
2000	4.80	34.0	108,0	2796

Prestazioni calcolate ipotizzando le temperature di ingresso/uscita circuito primario 80/70° C, secondario 10°/45° C ed una temperatura di accumulo di 60° C.
Performance calculated assuming a primary circuit inlet/outlet temperature of 80/70°C, secondary in/out 10°/45°C and a storage temperature of 60°C.

	Capacità accumulo (lt.) Storage tank capacity (lt.)
	Potenza di scambio (Kw) Heat exchanger power (Kw)

	Superficie di scambio (m²) Heat exchanger surface (m²)
	Portata ACS (l/h) DHW flow-rate (l/h)

	Contenuto acqua scambiatore (lt.) Heat exchanger capacity (lt.)
--	--



I prodotti della serie SOL INOX sono bollitori per la produzione e l'accumulo di acqua calda sanitaria realizzati in acciaio inox AISI 316 L.

Il doppio scambiatore permette di utilizzare, oltre alla caldaia tradizionale, una fonte di energia alternativa quale quella solare ma non solo. Lo scambiatore inferiore si sviluppa fino alla parte più bassa del bollitore riscaldando così una maggiore quantità di acqua.



The SOL INOX series products are storage tanks for the production and storage of domestic hot water made from AISI 316 L stainless steel. These feature a fixed heat exchanger with a large surface area and high capacity, making them ideal for the production of hot water. The double heat exchanger allows an alternative energy source to be used in addition to a normal boiler.

Tutti i serbatoi coibentati rispettano i requisiti richiesti dalle direttive 2009/125/CE e 2010/30/UE sull'efficienza energetica.

All the insulated tanks, comply with the directive 2009/125/CE and 2010/30UE about energy efficiency.

CARATTERISTICHE TECNICHE TECHNICAL FEATURES

Costruzione accumulo Storage tank construction	Acciaio inox AISI 316L Stainless steel AISI 316L
Isolamento Insulated	Poliuretano rigido iniettato, 200÷500 lt. spessore 50 mm Injected rigid polyurethane, 200÷500 lt. 50 mm thick
	ECOFIRE RIMOVIBILE, 800÷2000 lt. spessore 130 mm ECOFIRE REMOVABLE, 800÷2000 lt. 130 mm thick
Rivestimento esterno Outside covering	PVC accoppiato Laminated PVC
Accumulo Storage tank	Pmax 6 bar - Tmax 95°C
Scambiatore Heat exchanger	Pmax 12 bar - Tmax 95°C
Accessori di serie Standard accessories	Flangia d'ispezione - Anodo di magnesio Inspection flange - Magnesium anode
Garanzia Warranty	5 anni 5 years

SOLINOX

	Codice Code	€	Classe Energetica ErP
200	SOLINOX0200C		C
300	SOLINOX0300C		C
500	SOLINOX0500C		C
800	SOLINOX0800C		C
1000	SOLINOX1000C		C
1500	SOLINOX1500C		C
2000	SOLINOX2000C		C

Listino prezzi accessori e ricambi a pagina 116

Accessories and spare parts price list available at page 116

Esempio di impianto Example of a system

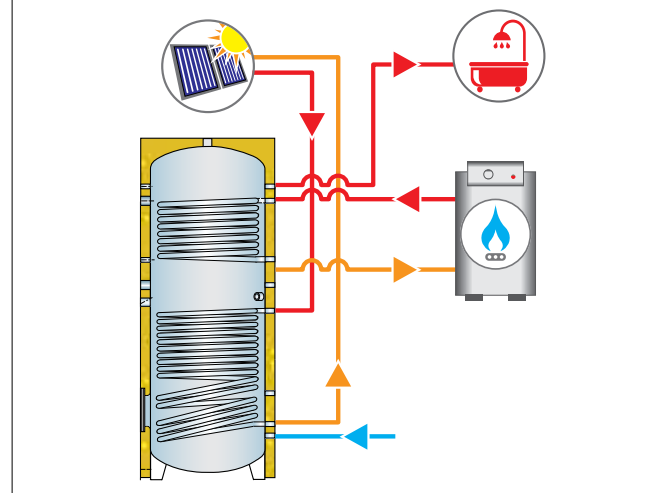

Uso: acqua calda sanitaria
Use: domestic hot water

Abbinabile con:
Combined with:



Disegno tecnico Technical drawing

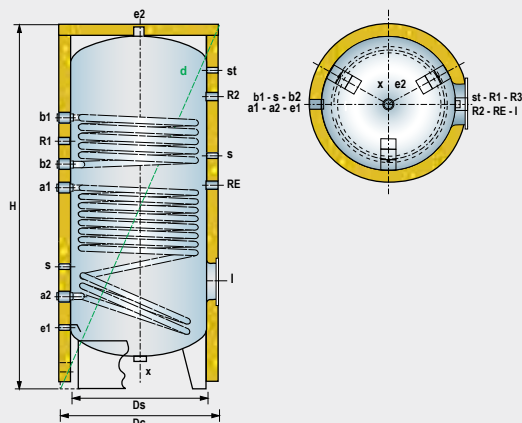

a1-a2	Entrata / uscita scambiatore Heat exchanger inlet / outlet
b1-b2	Entrata / uscita scambiatore integrato Additional heat exchanger inlet / outlet
e1	Entrata acqua sanitaria / scarico Domestic water inlet / drain
e2	Uscita acqua sanitaria Primary circuit outlet
s	Attacco sonda Probe fitting
RE	Attacco resistenza elettrica / Ricircolo Electric heater fitting / Ricircolo
R1-R2	Servizio Service
st	Attacco termometro Thermometer
x	Scarico Drain
I	Flangia d'ispezione Inspection flanges

	CONNESSIONI CONNECTIONS									
	a1-a2	b1-b2	e1-e2	s	RE	R1	R2	st	x	I
200+500	G1"-F	G1"-F	G1"-F	G 1/2"-F	G1"1/2-F	G 1/2"-F	G1"1/4-F	G 1/2"-F	-	Øi120 Øe180
800-1000	G1"-F	G1"-F	G1"1/2-F	G 1/2"-F	G1"1/2-F	G1"-F	-	G 1/2"-F	G1"-F	Øi120 Øe180
1500-2000	G1"-F	G1"-F	G2"-F	G 1/2"-F	G1"1/2-F	G1"-F	-	G 1/2"-F	G1"-F	Øi220 Øe290

	DIMENSIONALE SIZES (mm)										
	Ds	Dc	H R1	H a1	H a2	H	H b1	H b2	Kg	H RE	Kg
200	450	550	840	630	190	1290	950	740	60	690	60
300	500	600	1050	790	230	1580	1200	900	80	845	80
500	650	750	1095	840	240	1630	1250	950	105	895	105
800	790	1050	1200	870	275	1815	1385	1010	150	940	150
1000	790	1050	1400	1020	275	2160	1635	1160	170	1090	170
1500	1000	1260	1460	1120	375	2195	1675	1250	250	1180	250
2000	1100	1360	1755	1350	465	2615	2015	1490	330	1420	330

	PRESTAZIONI PERFORMANCE							
	Scambiatore inferiore Bottom heat exchanger				Scambiatore superiore Top heat exchanger			
200	0.90	6.5	21,5	559	0.50	3.5	13,0	335
300	1.30	9.2	32,2	838	0.85	6.0	21.4	559
500	2.00	13.8	45,0	1175	1.10	7.8	25.7	670
800	2.70	19.0	56,0	1510	1.50	10.6	32.1	838
1000	3.00	6.5	64,4	1677	1.90	13.5	40.7	1062
1500	3.70	26.3	79,4	2068	2.30	16.3	49.4	1285
2000	4.80	34.0	108,0	2796	3.00	21.3	64.4	1677

Prestazioni calcolate ipotizzando le temperature di ingresso/uscita circuito primario 80/70° C, secondario 10°/45° C ed una temperatura di accumulo di 60° C.
Performance calculated assuming a primary circuit inlet/outlet temperature of 80/70°C, secondary in/out 10°/45°C and a storage temperature of 60°C.

	Capacità accumulo (lt.) Storage tank capacity (lt.)
	Potenza di scambio (Kw) Heat exchanger power (Kw)

	Superficie di scambio (m²) Heat exchanger surface (m²)
	Portata ACS (l/h) DHW flow-rate (l/h)

	Contenuto acqua scambiatore (lt.) Heat exchanger capacity (lt.)
--	--



I prodotti della serie 216 INOX sono accumulatori per acqua calda sanitaria realizzati in acciaio inox AISI 316 L.
L'accumulo termico viene utilizzato per lo stoccaggio di acqua calda sanitaria proveniente, tipicamente, da scambiatori a piastre.



The 216 INOX series products are domestic hot water storage tanks made from AISI 316 L stainless steel.
The storage tank is used to store domestic hot water typically coming from plate heat exchangers.

Tutti i serbatoi coibentati rispettano i requisiti richiesti dalle direttive 2009/125/CE e 2010/30/UE sull'efficienza energetica.
All the insulated tanks, comply with the directive 2009/125/CE and 2010/30UE about energy efficiency.

CARATTERISTICHE TECNICHE TECHNICAL FEATURES

Costruzione accumulo <i>Storage tank construction</i>	Acciaio inox AISI 316L <i>Stainless steel AISI 316L</i>
Isolamento <i>Insulated</i>	Poliuretano rigido iniettato, 300÷500 lt. spessore 50 mm <i>Injected rigid polyurethane, 300÷500 lt. 50 mm thick</i>
	ECOFIRE RIMOVIBILE, 800÷2000 lt. spessore 100 mm <i>ECOFIRE REMOVABLE, 800÷2000 lt. 100 mm thick</i>
	ECOFIRE RIMOVIBILE, 2500÷5000 lt. spessore 100 mm <i>ECOFIRE REMOVABLE, 2500÷5000 lt. 100 mm thick</i>
Rivestimento esterno <i>Outside covering</i>	PVC accoppiato <i>Laminated PVC</i>
Accumulo <i>Storage tank</i>	Pmax 6 bar - Tmax 95°C
Accessori di serie <i>Standard accessories</i>	Flangia d'ispezione - Anodo di magnesio <i>Inspection flange - Magnesium anode</i>
Garanzia <i>Warranty</i>	5 anni <i>5 years</i>

216INOX

	Codice Code	€	Classe Energetica ErP
300	216INOX0300C		C
500	216INOX0500C		C
800	216INOX0800C		C
1000	216INOX1000C		C
1500	216INOX1500C		C
2000	216INOX2000C		C
2500	216INOX2500C		C
3000	216INOX3000C		C
4000	216INOX4000C		C
5000	216INOX5000C		C

Listino prezzi accessori e ricambi a pagina 116
Accessories and spare parts price list available at page 116

Esempio di impianto Example of a system

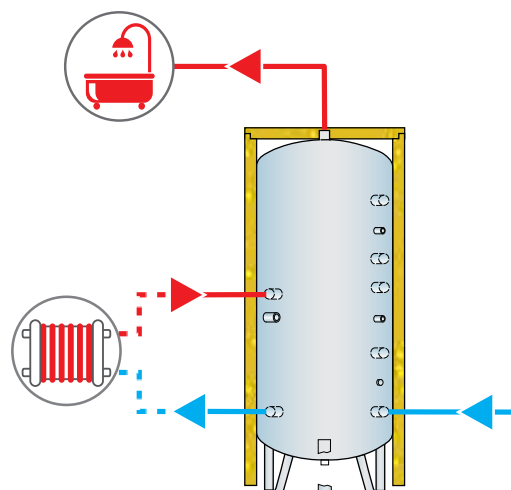

Prodotti conformi alla direttiva 2014/68/UE PED (Art.4 Par.3)
Products complying with the directive 2014/68/UE PED (Art.4 Par.3)



Disegno tecnico *Technical drawing*

Capacity 300÷5000

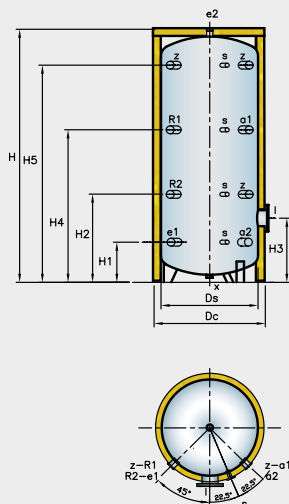

a1-a2	Entrata/uscita scambiatore esterno <i>External heat exchanger inlet/outlet</i>
e1	Entrata acqua sanitaria <i>Domestic water inlet</i>
e2	Uscita acqua sanitaria <i>Primary circuit outlet</i>

s	Attacco sonda <i>Probe fitting</i>
R1-R2	Attacco resistenza elettrica / ricircolo <i>Electric heater fitting / recirculation</i>
z	Servizio <i>Service</i>

u	Scarico / Servizio <i>Drain / Service</i>
x	Scarico <i>Drain</i>
GR	Gruppo di scarico <i>Drain assembly</i>

	CONNESSIONI CONNECTIONS							
	a1-a2	e1-e2	s	z	R1	R2	x	l
300-500	G1"1/4-F	G1"1/4-F	G 1/2"-F	G1"1/4-F	G1"1/2-F	G1"1/4-F	G1"-F	220x290
800-1000	G1"1/4-F	G1"1/2-F	G 1/2"-F	G1"1/4-F	G1"1/2-F	G1"1/4-F	G1"1/2-F	300x380
1500	G1"1/4-F	G2"-F	G 1/2"-F	G1"1/4-F	G1"1/2-F	G1"1/4-F	G1"-F	300x380
2000-2500	G1"1/4-F	G2"-F	G 1/2"-F	G1"1/4-F	G1"1/2-F	G1"1/4-F	G1"-F	350x430
3000÷5000	G1"1/4-F	G3"-F	G 1/2"-F	G1"1/4-F	G1"1/2-F	G1"1/4-F	G1"-F	350x430

	DIMENSIONALE SIZES (mm)									
	Ds	Dc	H	H1	H2	H3	H4	H5	d	kg
300	500	600	1580	405	845	300	1250	1050	1690	61
500	650	750	1630	395	895	310	1280	1095	1794	78
800	790	1050	1815	425	940	345	1250	1200	2100	109
1000	790	1050	2160	430	1090	345	1450	1400	2400	127
1500	1000	1260	2195	340	765	520	1400	1725	2530	197
2000	1100	1360	2615	475	1010	655	1515	1925	2948	258
2500	1200	1400	2645	505	1040	690	1600	2105	2995	310
3000	1250	1450	2845	515	1100	675	1730	2300	3195	333
4000	1400	1600	2975	595	1190	755	1815	2380	3380	490
5000	1600	1800	3005	600	1185	825	1815	2385	3505	575



218INOX

Serbatoi inerziali per impianti di refrigerazione
Storage tanks for cooling systems



1500÷5000 lt



100÷1000 lt



I prodotti della serie 218 INOX sono accumulatori per acqua refrigerata realizzati in acciaio inox.

Funzionano in collegamento con impianti di condizionamento allo scopo di aumentarne il volano termico e diminuire il numero di avviamenti del gruppo frigorifero.



The 218 INOX series products are chilled water storage tanks made from stainless steel.

These are used in air-conditioning systems for increasing thermal inertia and reducing the number of start-ups of the chillers.

CARATTERISTICHE TECNICHE TECHNICAL FEATURES

Costruzione accumulo Storage tank construction	Acciaio inox AISI 304L Stainless steel AISI 304L
Isolamento Insulated	100÷5000 lt. Anticondensa, spessore 20 mm 100÷5000 lt. Anti-condensation 20 mm thick
Rivestimento esterno Outside covering	PVC accoppiato Laminated PVC
Accumulo Storage tank	Pmax 6 bar - Tmax 60°C
Garanzia Warranty	3 anni 3 years

218INOX

	Codice Code	€
100	218INOX0100C	
200	218INOX0200C	
300	218INOX0300C	
500	218INOX0500C	
800	218INOX0800C	
1000	218INOX1000C	
1500	218INOX1500C	
2000	218INOX2000C	
3000	218INOX3000C	
4000	218INOX4000C	
5000	218INOX5000C	

Esempio di impianto Example of a system

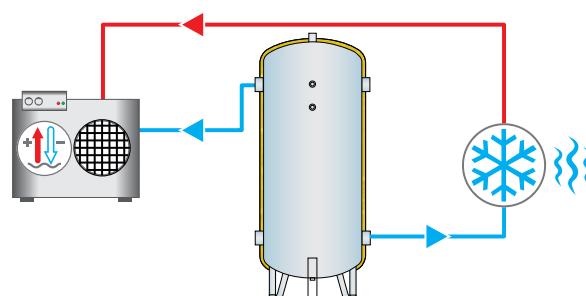

Listino prezzi accessori e ricambi a pagina 116

Accessories and spare parts price list available at page 116

Disegno tecnico *Technical drawing*

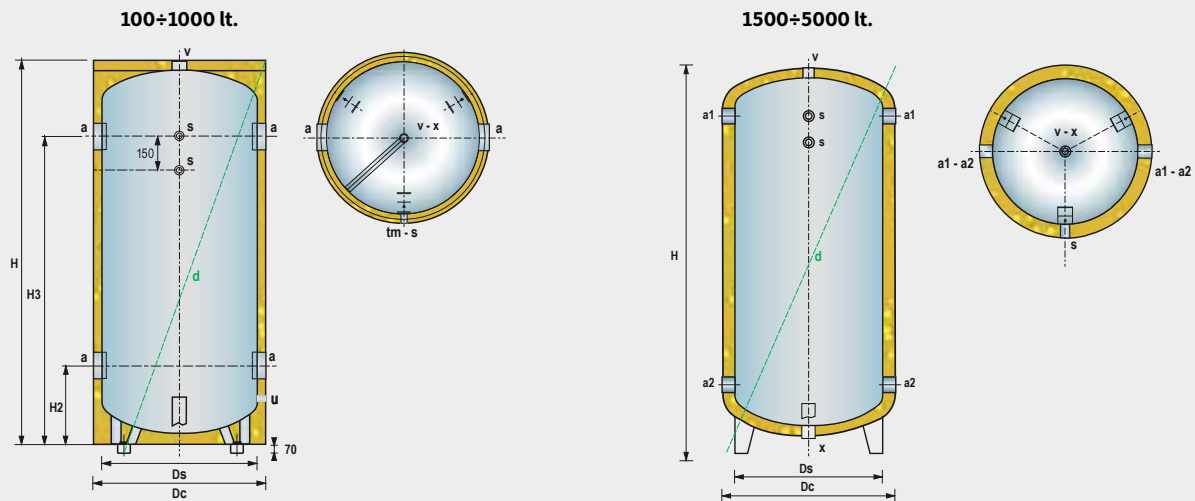

a1-a2 Alimentazione / utilizzo
Supply / usage

v Sfiato
Vent

s Attacco sonda
Probe fitting

x Scarico
Drain

u Servizio / Scarico
Service / Drain

lt	CONNESSIONI CONNECTIONS				
	a1-a2	v	s	u	x
100-200	G1"1/2-F	G1"1/4-F	G 1/2"-F	G1"-F	-
300	G2"-F	G1"1/4-F	G 1/2"-F	G1"-F	-
500	G3"-F	G1"1/4-F	G 1/2"-F	G1"-F	-
800-1000	G3"-F	G1"1/2-F	G 1/2"-F	G1"-F	-
1500-2000	G3"-F	G1"1/2-F	G 1/2"-F	-	G1"1/2-F
3000÷5000	G4"-F	G1"1/2-F	G 1/2"-F	-	G1"1/2-F

lt	DIMENSIONALE SIZES (mm)						
	Ds	Dc	H a1	H	H a2	d	kg
100	400	440	710	890	210	1000	20
200	450	490	1095	1290	220	1385	30
300	500	540	1320	1570	275	1665	40
500	650	690	1350	1625	305	1775	60
800	790	830	1365	1660	320	1865	80
1000	790	830	1710	2005	320	2180	90
1500	1000	1040	1780	2140	485	2200	130
2000	1100	1140	1985	2460	490	2520	200
3000	1250	1290	2290	2720	535	2790	290
4000	1400	1440	2370	2850	615	2935	330
5000	1600	1640	2370	2880	620	2990	440

Per applicazioni caldo/freddo rivolgersi all'ufficio commerciale
For cooling and heating systems refer to our sales department



Listino ricambi e accessori Spare parts and accessories

ANODO DI MAGNESIO <i>MAGNESIUM ANODE</i>			
	Codice Code	Caratteristiche Features	€
	AND08	d 1" x 300 mm	
	ANDCEA06	d 1"1/4 x 400 mm 300÷1500 lt.	
	ANDCEA04	d 1"1/4 x 900 mm 2000÷5000 lt.	

KIT ANODO/I DI MAGNESIO + TESTER <i>MAGNESIUM ANODE/S + TESTER KIT</i>			
	Codice Code	Caratteristiche Features	€
	KITCEA04	1 Pz. 1"1/4 x 400 mm 300÷800 lt.	
	KITCEA06	• 2 Pz. 1"1/4 x 400 mm 1000÷1500 lt.	
	KITCEA08	2 Pz. 1"1/4 x 900 mm 2000÷5000 lt.	

ANODO/I CORRENTE IMPRESSA <i>IMPRESSED CURRENT PROTECTION</i>			
	Codice Code	Caratteristiche Features	€
	KITACI01	1 pz. M-1/2" x400 mm 300÷800 lt.	
	KITACI02	2 pz. M-1/2" x400 mm 1000÷1500 lt.	
	KITACI03	2 pz. M-1/2" x 800 mm 2000÷5000lt.	

SCAMBIATORE ESTRAIBILE ACCIAIO INOX <i>REMOVABLE STAINLESS STEEL HEAT EXCHANGER</i>			
	Codice Code	Caratteristiche Features	€
	UX075	0.75 m ² - Dn 300 - 16 fori holes	
	UX1	1.00 m ² - Dn 300 - 16 fori holes	
	UX15	1.50 m ² - Dn 380 - 19 fori holes	
	UX2	2.00 m ² - Dn 380 - 19 fori holes	
	UX3	3.00 m ² - Dn 380 - 19 fori holes	
	UX4	4.00 m ² - Dn 430 - 22 fori holes	
	UX5	5.00 m ² - Dn 430 - 22 fori holes	
	UX6	6.00 m ² - Dn 430 - 22 fori holes	
	UX8	8.00 m ² - Dn 430 - 22 fori holes	
	UX10	10.00 m ² - Dn 430 - 22 fori holes	

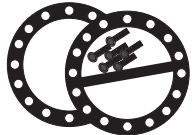
KIT GUARNIZIONI, BULLONI, ISOLATORI <i>KIT OF GASKET, BOLTS, INSULATORS</i>													
	Codice Code	Caratteristiche Features	Abbinabile con m ² Combined with m ²										€
			0.75	1	1.5	2	3	4	5	6	8	10	
			KITGBI01	Dn 300 - 16 fori holes	✓	✓	✗	✗	✗	✗	✗	✗	
KITGBI02	Dn 380 - 19 fori holes	✗	✗	✓	✓	✓	✗	✗	✗	✗	✗	✗	
KITGBI03	Dn 430 - 22 fori holes	✗	✗	✗	✗	✗	✓	✓	✓	✓	✓	✓	

TESTATA ZINCATA <i>GALVANISED HEADER</i>													
	Codice Code	Caratteristiche Features	Abbinabile con m ² Combined with m ²										€
			0.75	1	1.5	2	3	4	5	6	8	10	
			TZ01	Dn 300 - 16 fori holes	✓	✓	✗	✗	✗	✗	✗	✗	
TZ02	Dn 380 - 19 fori holes	✗	✗	✓	✓	✓	✗	✗	✗	✗	✗	✗	
TZ03	Dn 430 - 22 fori holes	✗	✗	✗	✗	✗	✓	✓	✓	✓	✓	✓	

SCAMBIATORE ESTRAIBILE VAPORE AISI 316L COMPLETO DI TESTA ZINCATA
REMOVABLE EXCHANGER AISI 316L C/W GALVANIZED HEADER

	Codice Code	Caratteristiche Features	€
	SCVBP1	1 m ² - Dn 300 - 16 fori holes	
	SCVBP1,5	1.5 m ² - Dn 380 - 19 fori holes	
	SCVBP2	2 m ² - Dn 380 - 19 fori holes	
	SCVBP3	3 m ² - Dn 380 - 19 fori holes	
	SCVBP4	4 m ² - Dn 430 - 22 fori holes	
	SCVBP5	5 m ² - Dn 430 - 22 fori holes	

KIT GUARNIZIONI PER VAPORE KIT OF GASKET FOR STEAM

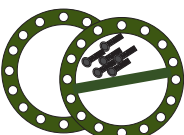
	Codice Code	Caratteristiche Features	Abbinabile con m ² Combined with m ²					€	
			1	1.5	2	3	4		5
	KITEVAPO5	Dn 300 - 16 fori holes	✓	✗	✗	✗	✗	✗	
	KITEVAPO6	Dn 380 - 19 fori holes	✗	✓	✓	✓	✗	✗	
	KITEVAPO7	Dn 430 - 22 fori holes	✗	✗	✗	✗	✓	✓	

QUADRO DI COMANDO ELETTRONICO ELECTRONIC CONTROL PANEL KIT

	Codice Code	Caratteristiche Features	€
	2301015	Kit completo Complete kit	
	SC01	Scheda elettronica Electronic board	
	SND01	Sonda temp. NTC NTC temp. probes	

RESISTENZE ELETTRICHE IN ACCIAIO INOX
STAINLESS STEEL ELECTRIC HEATERS

	Codice Code	Caratteristiche Features	€
	0409057	2Kw - 1 1/4" - 300mm - 230 V	
	0409058	3Kw - 1 1/4" - 370mm - 230 V	
	0409059	4Kw - 1 1/4" - 370mm - 230 V	
	0409060	4Kw - 2" - 620mm - 380 V	
	0409061	5Kw - 2" - 620mm - 380 V	
	0409062	6Kw - 2" - 730mm - 380 V	
	0409064	8Kw - 2" - 730mm - 380 V	
	0409065	9Kw - 2" - 730mm - 380 V	
	0409066	10Kw - 2" - 920mm - 380 V	
	0409067	12Kw - 2" - 920mm - 380 V	

RESISTENZE ELETTRICHE IN ACCIAIO INOX
CON TERMOSTATO
STAINLESS STEEL ELECTRIC HEATERS WITH THERMOSTAT

	Codice Code	Caratteristiche Features	€
	0409068	2Kw - 1 1/4" - 300mm - 230 V	
	0409069	3Kw - 1 1/4" - 370mm - 230 V	
	0409070	4Kw - 1 1/4" - 370mm - 230 V	
	0409071	4Kw - 2" - 620mm - 380 V	
	0409072	5Kw - 2" - 620mm - 380 V	
	0409073	6Kw - 2" - 730mm - 380 V	
	0409075	8Kw - 2" - 730mm - 380 V	
	0409076	9Kw - 2" - 730mm - 380 V	
	0409077	10Kw - 2" - 920mm - 380 V	
	0409078	12Kw - 2" - 920mm - 380 V	

Resistenza elettrica con protezione IP40.

Termostato di sicurezza regolabile con protezione IP55.

Electric heater with IP40 protection.

Security thermostat with IP55 protection.

Perdite di carico scambiatori estraibili

Removable heat exchanger pressure drop



Dai diagrammi seguenti si ricavano le “perdite di carico” per gli scambiatori estraibili a fascio tubiero utilizzati nei bollitori per acqua calda.

Per ogni tipologia di scambiatore, si riporta l’andamento della caduta di pressione in mm c.a., in funzione della portata espressa in litri al minuto.



The following diagrams show the “pressure drop” for the removable heat tube bundle heat exchangers used in the hot water storage tanks.

For each type of heat exchanger, the trend in pressure drop is shown in mmWC, according to the flow-rate expressed in litres per minute.

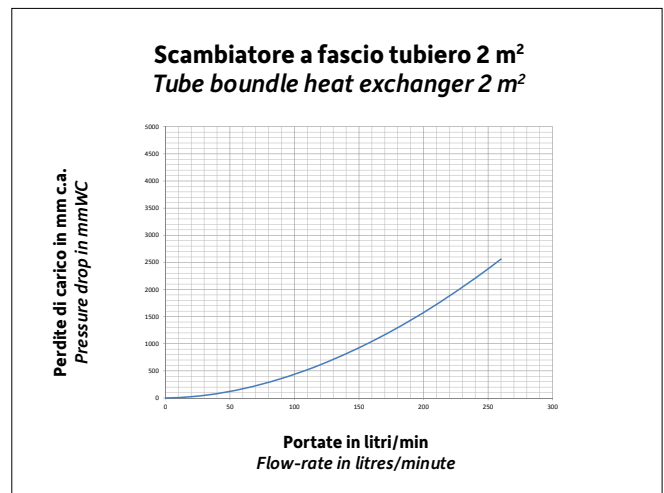
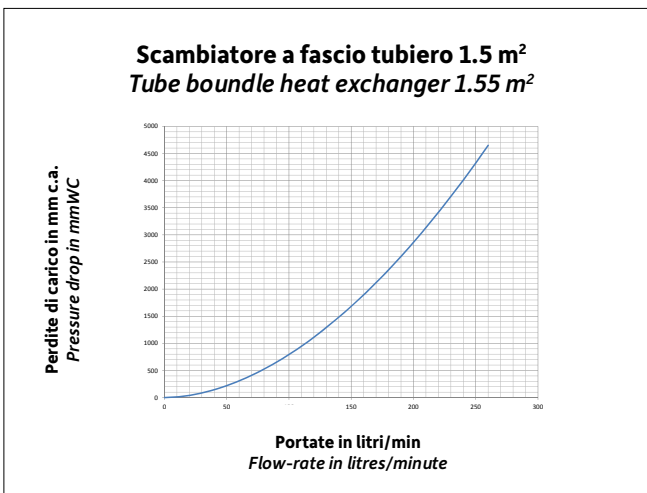
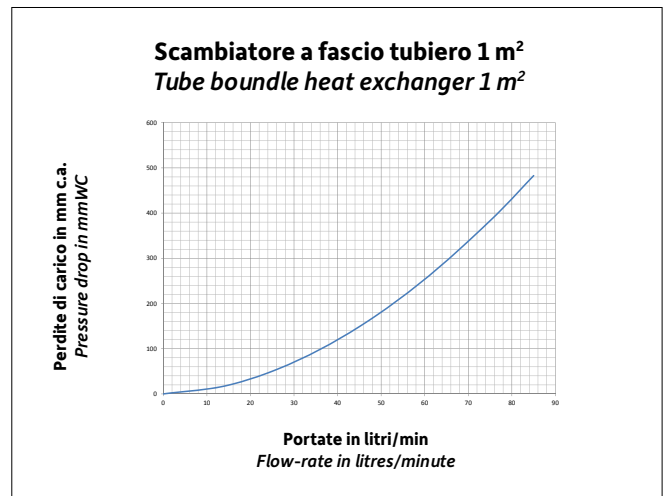
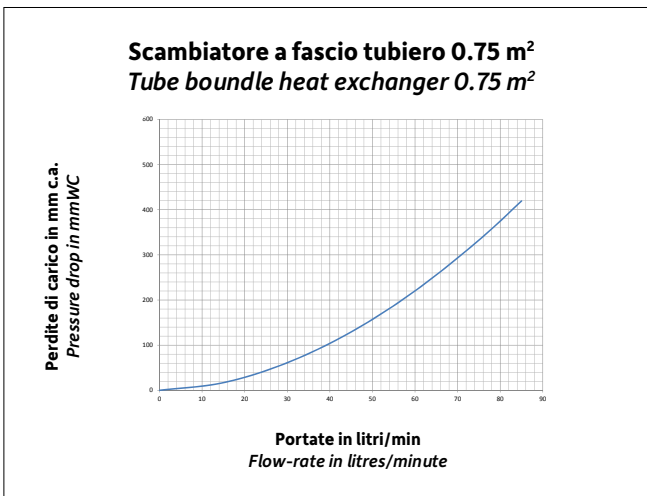

Scambiatore a fascio tubiero 3 m²
Tube bundle heat exchanger 3 m²

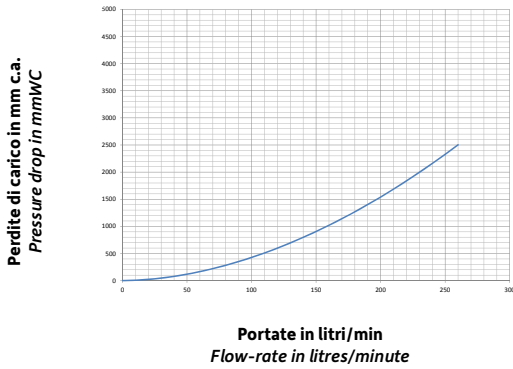

Scambiatore a fascio tubiero 4 m²
Tube bundle heat exchanger 4 m²

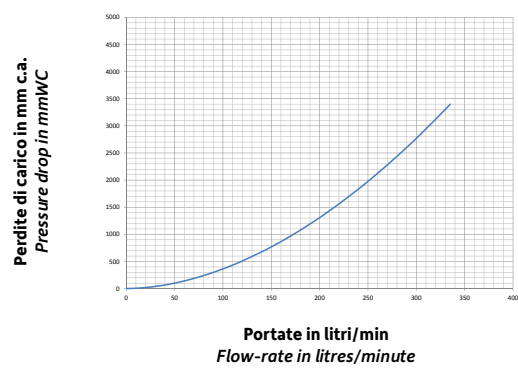

Scambiatore a fascio tubiero 5 m²
Tube bundle heat exchanger 5 m²

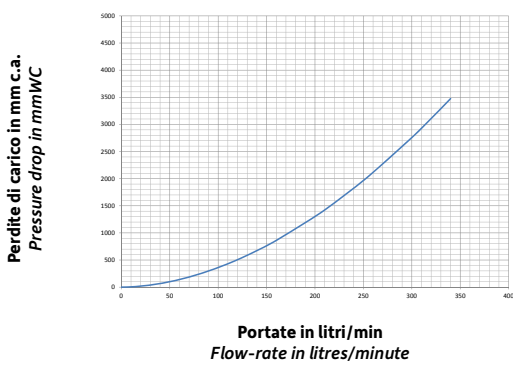

Scambiatore a fascio tubiero 6 m²
Tube bundle heat exchanger 6 m²

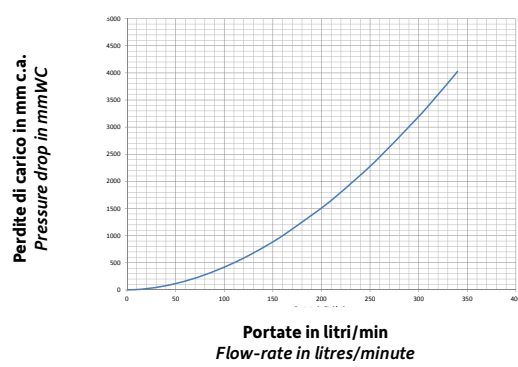

Scambiatore a fascio tubiero 8 m²
Tube bundle heat exchanger 8 m²

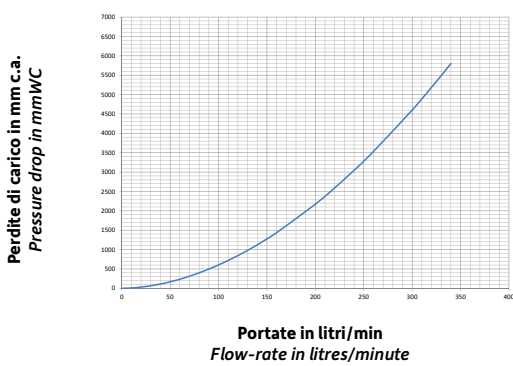

Scambiatore a fascio tubiero 10 m²
Tube bundle heat exchanger 10 m²

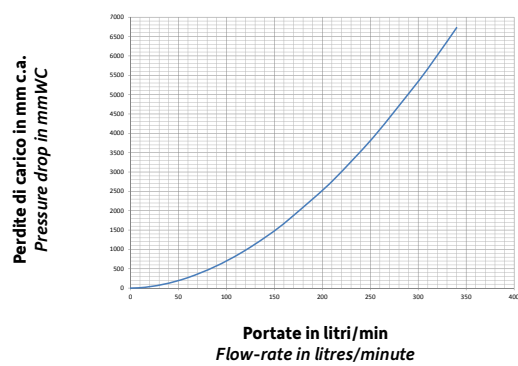

Condizioni generali di vendita 2020

General sale conditions 2020



PERFEZIONAMENTO DEL CONTRATTO

La presente scrittura equivale a proposta di compravendita, la quale si perfeziona o con la comunicazione di accettazione da parte del cliente a SICCTECH[®], o con l'inizio dell'esecuzione senza una preventiva risposta entro i 3 giorni stabiliti nella conferma d'ordine.

CONSEGNA

- SICCTECH[®] non potrà essere considerata inadempiente per eventuali ritardi nelle consegne fino ad un massimo di 90 giorni lavorativi rispetto al termine convenuto.
- L'acquirente resta obbligato a mantenere ferma la sua ordinazione per lo stesso periodo di tempo, con rinuncia a far valere una pretesa essenzialità del termine di consegna frattanto scaduto.
- Per ritardi superiori a detto periodo, l'acquirente ha facoltà di revocare la sua ordinazione, mediante raccomandata che dovrà pervenire alla sede SICCTECH[®] prima che questa dichiari pronta la consegna della merce.

SPEDIZIONI

La merce si intende sempre resa franco nostro magazzino. Qualora per speciali accordi la consegna venga stabilita franco destino si intende comunque resa su autocarro non scaricata: restano perciò a totale carico dell'acquirente tutti gli oneri ed i rischi relativi allo scarico. La merce, anche se venduta franco destino, viaggia sempre per conto e a rischio del committente. Pertanto non si sostituisce, né si accredita la merce manomessa, danneggiata o perduta durante il trasporto. I prodotti SICCTECH[®] vengono forniti non imballati; qualora il committente o il vettore richiedessero l'imballaggio, il costo dello stesso verrà addebitato al committente.

CARATTERISTICHE COSTRUTTIVE

I dati esposti nei cataloghi, le illustrazioni ed i disegni sono indicativi e non impegnano la ditta costruttrice ad una fedele esecuzione dei dettagli. Previa autorizzazione del cliente, SICCTECH[®] riserva la facoltà di apportare quelle modifiche che l'esperienza, le esigenze e i progressi tecnici suggeriscono e pertanto nessuna contestazione diretta, indiretta o accessoria potrà essere proposta a questo titolo. Farà fede a livello tecnico la descrizione del prodotto riportata nei documenti ufficiali di contratto quali la conferma d'ordine e gli eventuali disegni sottoposti per approvazione alla costruzione, quest'ultima evenienza solo nel caso si tratti di prodotti non standard e presenti a catalogo. I reclami circa la qualità e la quantità del materiale devono essere fatti a pena di decadenza, entro otto giorni dal ricevimento della merce, direttamente alla venditrice a mezzo raccomandata.

GARANZIA

- La SICCTECH[®] garantisce i propri prodotti come segue:
 - garanzia di 2 anni per tutti i prodotti acquistati dal consumatore (come definito dall'articolo 1 del Decreto Legislativo 2 Febbraio 2002, n. 24 /Attuazione della direttiva 1999/44/CE su taluni aspetti della vendita e delle garanzie di consumo).
 - garanzia di un anno per tutti i prodotti acquistati da soggetti diversi dal consumatore.
 - Il periodo di garanzia di ogni prodotto è indicato nel presente catalogo alla pagina corrispondente di ogni articolo.
 - Tutti gli accessori, anche se forniti assemblati sul prodotto finito, hanno garanzia 12 mesi (quadro di comando, anodi a corrente impressa, circolatori, pompe monoblocco, inverter, valvole di sicurezza e rompivuoto, scambiatori a piastre).
- La durata di tale garanzia decorre dalla consegna del prodotto al consumatore comprovata da idonea documentazione fiscale. Per effetto della garanzia SICCTECH[®], a propria discrezione, si limiterà a riparare o a sostituire gratuitamente il prodotto o i componenti che dovessero manifestare difetti di materiali, costruzione o progettazione. La garanzia non copre gli eventuali costi sostenuti dal cliente per smontaggio e montaggio dei prodotti che risultassero difettosi. Il cliente dovrà far pervenire il prodotto a proprie spese presso il nostro stabilimento per la verifica e l'eventuale riparazione o sostituzione in garanzia. La garanzia non copre difetti dovuti all'usura del prodotto durante il suo

normale funzionamento e/o dovuti a fattori esterni, quali, valori dell'acqua fuori dai limiti di legge (Direttive CEE 98/83), mancata manutenzione, errata o mancata installazione dei sistemi protettivi consigliati da SICCTECH[®], come anodi e messa a terra.

- E' esclusa comunque all'acquirente sia la domanda di risoluzione, sia la domanda di diminuzione del prezzo, sia quella del risarcimento del danno diretto o indiretto comunque conseguente.
- Cesserà qualsiasi garanzia da parte di SICCTECH[®] quando vengano apportate modifiche ai materiali o eseguite riparazioni da parte dei tecnici da essa non preventivamente autorizzati;
- La garanzia cesserà inoltre quando l'acquirente non si sia tenuto alle scadenze ed alle modalità di pagamento e quando non siano state rispettate tutte le istruzioni di uso e manutenzione di cui il prodotto è corredato.

PREZZI

I nostri prezzi sono soggetti a variazioni e non sono impegnativi senza espressa conferma da parte di SICCTECH[®]. Qualsiasi variazione dei prezzi sarà comunicata al cliente preventivamente.

PAGAMENTO

- Le fatture non contestate dall'acquirente entro otto giorni dal loro ricevimento, per lettera raccomandata, si intendono accettate definitivamente.
- Anche quando fosse concordato a mezzo tratta o effetti cambiari, il pagamento resta convenuto al domicilio della venditrice, a tutti gli effetti legali.
- A partire dal trentesimo giorno successivo alla data di pagamento, SICCTECH[®] addebiterà gli interessi di mora per un importo pari 3 punti base sul tasso corrente d'interesse fissato dalla Banca Centrale Europea. SICCTECH[®] si riserva il diritto di esigere il risarcimento di ulteriori danni subiti in termini di interessi. Sui pagamenti ritardati verranno conteggiati, di pieno diritto e senza alcuna messa in mora, gli interessi al tasso corrente bancario passivo applicato a SICCTECH[®].
- I pagamenti non potranno essere ritardati dall'acquirente né per gli effetti della garanzia e/o del collaudo, né per qualunque contestazione che dovesse sorgere tra le parti.
- Nessuna azione o domanda giudiziale è inoltre proponibile dall'acquirente se non previo assolvimento delle proprie obbligazioni.

RISERVATO DOMINIO

- SICCTECH[®] conserva la proprietà sui materiali compravenduti fino al completo pagamento della fornitura.
- La mancata corresponsione di una o più rate comporta automaticamente la decadenza dell'acquirente dal beneficio del termine in relazione alle rate successive oppure (a scelta di SICCTECH[®] da valere fino a quando non sia comunque intervenuto l'integrale pagamento del prezzo) la risoluzione di diritto del contratto.
- In tale ultima ipotesi, le rate eventualmente già riscosse da SICCTECH[®] saranno acquisite dalla stessa a titolo di indennità.

RESPONSABILITÀ

SICCTECH[®] è esonerata da ogni responsabilità per danni a persone e cose subiti anche da terzi in funzione di eventi comunque dipendenti dalla fornitura e ancorché connessi all'eventuale opera prestata in sede di installazione, montaggio o assistenza tecnica.

COMPETENZA GIUDIZIALE

Eventuali controversie inerenti l'interpretazione o l'esecuzione del contratto, sono devolute alla competenza del Foro di Rovigo.



This document represents a sales proposal, becoming effective as a sales contract either upon notification of acceptance by the customer to **SICCtech**, or when executed without prior response within 3 days from the date of **SICCtech** confirmation order.

DELIVERY

- a) **SICCtech** cannot be considered in default for any delays in deliveries up to a maximum of 90 working days from the agreed terms.
- b) The purchaser shall keep any orders open for the same period of time, waiving any claim that such delivery terms are binding once these have expired.
- c) For any delays exceeding such period, the purchaser may cancel the order, by registered mail, which must reach the **SICCtech** offices before the latter provides notification that it is ready to deliver the goods.

WARRANTY

- a) **SICCtech** guarantees its products as follows:
 - two year warranty on all products purchased by consumers (as specified by article 1 of Italian Legislative Decree no. 24 of 2 February 2002 - implementation of directive 1999/44/EC on the sale and supply of goods to consumers).
 - one year warranty on all products purchased by entities other than consumer.
 - The warranty period for each product is indicated in this catalog at the corresponding page of each article.
 - All the accessories, even though supplied along with the finished product, have 12 month guarantee (panel control, impressed current anodes, pumps, monobloc pumps, inverter, safety valves and vacuum breaker valves, plate heat exchangers).

The warranty period begins from delivery of the product to the consumer, as proven by a proper tax receipt.

Under the terms of the warranty, **SICCtech**, at its own discretion, will solely repair or replace free-of-charge the product or components that have defects in materials, workmanship or design.

The warranty does not cover any costs borne by the customer for dismantling and assembling the faulty products.

The customer must deliver the product at its own expense to our facilities, so as to verify and where necessary repair or replace the product under warranty.

The warranty does not cover defects due to product wear during the its normal operation and / or due to external factors, such as, values of water outside the limits of the law (EEC Directives 98/83), failure maintenance, incorrect or non-installation of protective systems recommended by **SICCtech**, such as anodes and grounding

- b) The purchaser may not request cancellation of the contract nor a reduction in price, nor compensation for direct or indirect damages as a consequence.
- c) Any warranties provided by **SICCtech** will terminate if any modifications are made to the materials or repairs are carried out by personnel without prior authorization;
- d) The warranty will furthermore terminate if the purchaser does not fulfill its obligations as regards the deadlines and methods of payment, and if all operating and maintenance instructions provided with the product are not complied with.

RETENTION OF TITLE

- a) Title to the goods sold remains vested in **SICCtech** until complete payment has been received.
- b) Failure to pay one or more instalments automatically results in the whole payment being due, or alternatively (at the discretion of **SICCtech** as an option until payment has been received in full) the right to cancel the contract.
- c) In the latter hypothesis, any instalments already received by **SICCtech** shall be retained as compensation.

DELIVERIES

The goods are always delivered ex-works.

If special arrangements are made for delivery with freight paid to destination, unloading of the vehicle is in any case not included: consequently, the purchaser is responsible for all costs and risks relating to unloading.

The goods, even if sold freight paid, always travel under the purchaser's responsibility and at its own risk.

Consequently, no replacements or credit shall be provided for goods that are tampered with, damaged or lost during transit.

SICCtech products are supplied unpackaged; if the purchaser or carrier requires packaging, the cost of such will be charged to the purchaser.

PRICES

Our prices may be changed without prior notice and are not binding unless expressly confirmed by **SICCtech**.

CONSTRUCTIONAL CHARACTERISTICS

The data specified in the catalogues, the illustrations and drawings are purely indicative; the manufacturer in no way guarantees that the details will be reproduced faithfully.

SICCtech likewise has the right to make any changes resulting from experience, requirements and technical advances, and consequently no direct, indirect or other objections may be raised in this regard.

Official description has to be intended as the description in the official documents as order confirmation or drawings submitted for approval, this last case only the product is not a standard product listed in the official catalogue.

Possible claims have to be submitted within 8 days from goods receiving and **SICCtech** has to be informed by Registered Letter.

PAYMENT

- a) Even when the means of payment is agreed upon as bank draft or note payable, payment is legally considered as being made at the seller's domicile.
- b) Overdue payments after 30 days will be automatically charged interest at 3% more than the legal interest rate by BCE.
- c) Payments may not be delayed by the purchaser, neither following a claim under warranty and/or testing, nor for any disputes that may arise between the parties.
- d) No additional legal action or claims may be made by the purchaser unless it has already fulfilled all of its own obligations.

LIABILITY

SICCtech declines all liability for any damage to people and things, including third parties, as a result of events depending on the goods supplied or in any way relating to work performed for installation, assembly or technical service.

MISCELLANEOUS

- a) Any claims involving the quality and the quantity of the material supplied must be made within eight days from receipt of the goods, directly to the seller by registered mail. No claims will be accepted after such period.
- b) Invoices that are not disputed by the purchaser within eight days of receipt, by registered mail, are considered as having been fully accepted.

JURISDICTION

Any disputes relating to the interpretation or the execution of the contract are the jurisdiction of the Court of Rovigo.

CATALOGO E LISTINO 2024
CATALOG AND PRICE LIST 2024

Edizione o.1 - Gennaio 2024
Edition n.1 - January 2024



SICC TECH s.r.l. Unipersonale
V.le Porta Po 89 z.i. - 45100 Rovigo Italy
Tel. +39.0425.403111
www.sicc-tech.it - info@sicc-tech.it



SICC TECH s.r.l.

V.le Porta Po 89 z.i. - 45100 Rovigo Italy

Tel. +39.0425.403111

www.sicc-tech.it - info@sicc-tech.it