



AQUACIAT^{CALEO} TD

Heat pump



Compact and silent

Optimised for heating

High energy efficiency

Winter operation down to -20°C

Hot water production up to +65°C

Heating capacity : 20 to 101 kW



Heating



Hydraulic
module

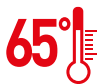

USE

The new generation of **AQUACIAT^{CALEO}** heat pumps offers an optimal solution for all heating applications encountered in the Offices, Healthcare, Hotels, Administration, Shopping Centres and Collective Housing markets.

These units are designed for outdoor installation and require no special protection against adverse weather conditions.

The **AQUACIAT^{CALEO}** uses outdoor air as the sole source of thermal energy for heating during the winter. Connected to high temperature static radiators, an underfloor heating system or comfort units, it produces hot water at +65°C at an outdoor temperature of -10°C which allows existing buildings to be heated with the greatest of ease.

Connected to a domestic hot water (DHW) production system with buffer tank capacity, the **AQUACIAT^{CALEO}** allows for complete autonomy of the domestic hot water and conventional heating system, whilst guaranteeing comfort and considerable energy savings.

The **AQUACIAT^{CALEO}** is optimised to use ozone-friendly HFC R407C refrigerant.

This range guarantees compliance with the most demanding requirements for increased seasonal energy efficiency (SCOP) and CO₂ reduction to comply with the various applicable European directives and regulations.

RANGE

AQUACIAT^{CALEO} TD series

Heating only version.

DESCRIPTION

AQUACIAT^{CALEO} units are packaged machines supplied as standard with the following components:

- Hermetic SCROLL compressors
- Water-cooled condenser, with brazed plates
- Air-cooled evaporator with axial fan motor assembly
 - copper tube coil, aluminium fins
- Electrical power and remote control cabinet:
 - 400V-3ph-50Hz (+/-10%) general power supply + Earth
 - transformer fitted as standard on the machine for supplying the remote control circuit with 24V
- Connect Touch electronic control module
- Hydraulic module with variable speed single pump
- Casing for outdoor installation

The entire AQUACIAT^{CALEO} range complies with the following EC directives and standards:

- Machinery directive 2006/42/EC
- Electromagnetic compatibility directive 2014/30/EC
- EMC immunity and emissions EN 61800-3 'C3'
- Low voltage directive 2014/35/EU
- RoHS 2011/65/EU
- Pressure equipment directive (PED) 2014/68/EU
- Machinery directive EN 60-204 -1
- Refrigerating systems and heat pumps EN 378-2

DESIGNATION

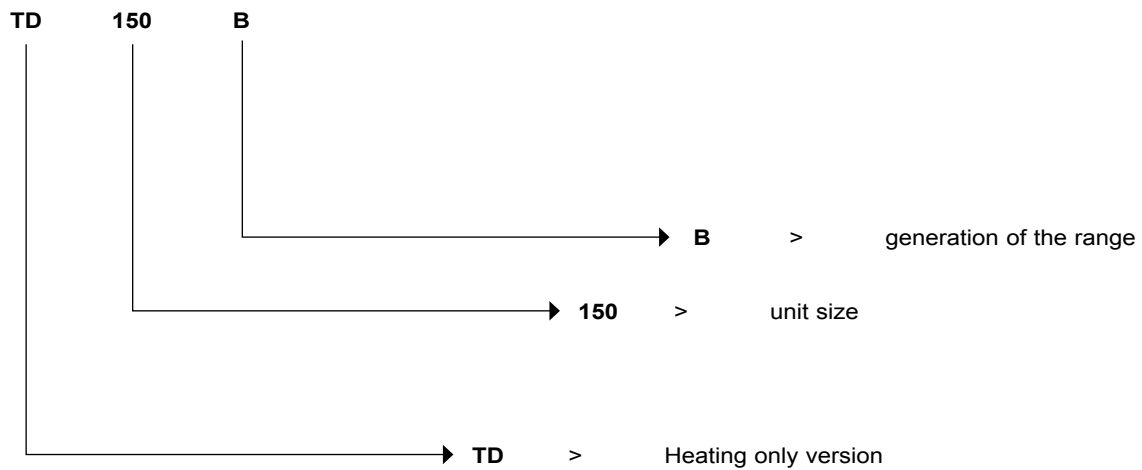

CONFIGURATION

TD	Standard
TD LN option	Standard Low Noise
TD XLN Option	Standard Xtra Low Noise

DESCRIPTION OF THE MAIN COMPONENTS

■ Compressors

- Hermetic SCROLL type
- Electronic motor overheating protection
- Crankcase heater
- Mounted on anti-vibration mounts

■ Water type heat exchanger

- Brazed-plate exchanger
- Plate patterns optimised for high efficiency
- 19 mm armafex thermal insulation
- Frost protection with heater

■ Air-cooled exchanger

- Coil made of grooved copper tubes with high-performance aluminium fins
- propeller fans with composite blades offering an optimised profile
- motors – IP 54, class F

■ Refrigerant accessories

- Dehumidifier filters
- Hygroscopic sight glasses
- Electronic expansion valves
- Service valves on the liquid line
- Four-way reverse cycle valve for defrosting

■ Regulation and safety instruments

- Low and high pressure sensors
- Safety valves on refrigerating circuit
- Water temperature control sensors
- Evaporator antifreeze protection sensor
- Factory-fitted evaporator water flow rate controller

■ Electrical cabinet

- Electrical cabinet with IP 44 protection rating
- A connection point without neutral
- Front-mounted main safety switch with handle
- Control circuit transformer
- 24V control circuit
- Fan and compressor motor circuit breaker
- Fan and compressor motor contactors
- Connect Touch microprocessor-controlled electronic control module
- Wire numbering
- Marking of the main electrical components

■ Frame

- Frame made from RAL7035 light grey & RAL 7024 graphite grey painted panels.

■ Connect Touch control module

- User interface with 4.3-inch touch screen
- Intuitive, user-friendly navigation using icons
- Clear text display of information available in 6 languages (F-GB-D-E-I-NL)



The electronic control module performs the following main functions:

- Regulation of the water temperature (at the return or at the outlet)
- Regulation of the water temperature based on the outdoor temperature (water law)
- Regulation for low temperature energy storage
- Second setpoint management
- Complete management of compressors with start-up sequence, timer and operating time balancing
- Self-regulating and proactive functions with adjustment of the control to counter parameter drift
- Optimised defrosting with free defrost function to optimise performance at partial load and the SCOP
- In-series staged power control system on the compressors according to the thermal requirements
- Management of compressor short cycle protection
- Frost protection (exchanger heaters)
- Phase reversal protection
- Management of occupied/unoccupied modes (according to the time schedule)
- Compressor and pump runtime balancing
- Management of the machine operation limit according to outdoor temperature
- Sound level reduction device (night mode according to the user programme) with limitation of compressor capacity and fan speed
- Diagnostics of fault and operating statuses
- Management of a fault memory allowing a log of the last 50 incidents to be accessed, with operating readings taken when the fault occurs
- Blackbox memory
- Master/slave management of the two machines in parallel with operating time balancing and automatic changeover if a fault occurs on one machine
- Weekly and hourly time schedule for the machine, including 16 periods of absence
- Pump standby based on demand (energy saving)
- Calculation of the water flow rate and operating pressure (hydraulic module version)
- Electronic adjustment of the water pump speed and water flow rate (variable-speed pump option)
- Display of all machine parameters (3 access levels, User/Maintenance/Factory, password-protected): temperature, setpoints, pressures, water flow rate (hydraulic version), runtime.
- Display of trend curves for the main values
- Storage of maintenance manual, wiring diagram and spare parts list.

AVAILABLE OPTIONS

■ Remote management

Connect Touch is equipped as standard with an RS485 port and an ETHERNET (IP) connection, offering a range of options for remote management, monitoring and diagnostics. Using the integrated Webservice, a simple internet connection uses the unit's IP address to access the Connect Touch interface on the PC, facilitating everyday management tasks and maintenance operations.

A range of communication protocols are available: MODBUS/JBUS RTU (RS485) or TC/IP as standard, LONWORKS – BACNET IP (certified BTL) as an option, enabling most CMS/BMS to be integrated.

Several contacts are available as standard, enabling the machine to be controlled remotely by wired link:

- Automatic operation control: when this contact is open, the machine stops
- Setpoint 1/setpoint 2 selector: when this contact is closed, a second Heating setpoint is activated (unoccupied mode, for example)
- Fault reporting: fault reporting: this contact indicates the presence of a major fault which has caused the machine to stop
- Domestic hot water demand
- On/off control for a boiler
- 4-stage on/off management for additional heaters.

Contacts available as an option:

- Setpoint adjustable via 4-20 mA signal: used to adjust the setpoint

■ Maintenance

Connect Touch has two maintenance reminder functions as standard, making users aware of the need to regularly perform maintenance operations and to guarantee the service life and performance of the unit. These two functions can be activated independently.

A reminder message appears on the unit's HMI screen, and stays there until it is acknowledged by the maintenance operator. The information and alert relating to these functions are available on the communication bus to be used on the CMS/BMS.

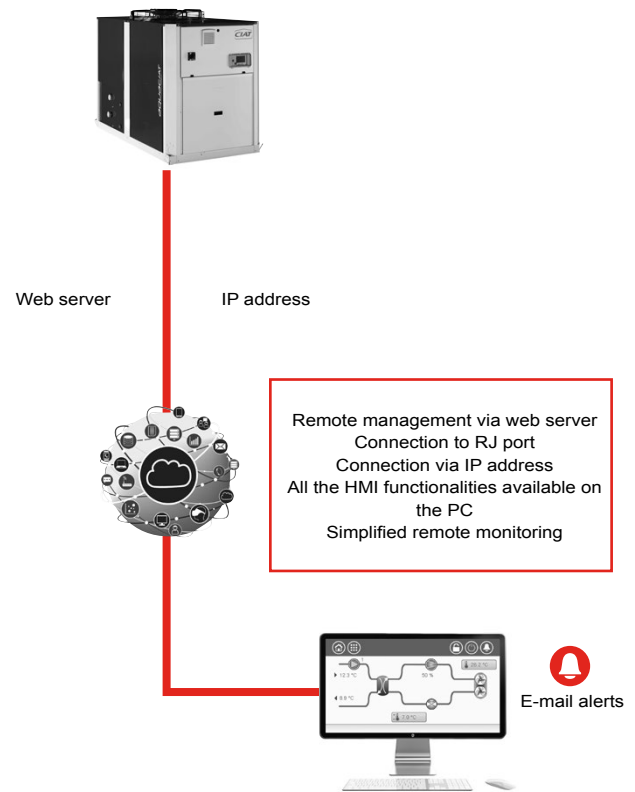

- the scheduled maintenance reminder: when activated, this function enables the period between two maintenance inspections to be set. This period may be set by the operator in either days, months or operating hours, depending on the application.

- the compulsory F-GAS sealing test maintenance reminder: when activated, this function, which is the default factory setting, enables the period between two sealing tests to be selected, according to the refrigerant charge, in compliance with the FGAS regulations

SEASONAL PERFORMANCES IN HEATING MODE

■ CIATM2M, the CIAT supervision solution

CIATM2M is a remote supervision solution dedicated to monitoring and controlling several CIAT machines in real time.

Advantages

- Access to the operating trend curves for analysis
- Improved energy performance
- Improved availability rate for the machines

Functions

CIATM2M will send data in real time to the supervision website, www.ciatm2m.com.

The machine operating data can be accessed from any PC, smartphone or tablet.

Any event can configured to trigger a mail alert.

Parameters monitored:

- Overview
- Control panel for the controllers
- Events
- Temperature curves

Monthly and annual reports are available to analyse:

- The performance and operation of the machine
Example: operating curves and time, number of compressor start-ups, events, preventive maintenance actions to be performed, etc.
- The electricity consumed (if the energy meter option is present)

Incidents such as a drift in the measurements on a temperature sensor, incorrectly set control parameters, or even incorrect settings between one compressor stage and the other are immediately detected, and the corrective actions put in place.

Equipment

This kit can be used on both machines which are already in use (existing inventory), and on new machines which do not have sufficient space in their electrical cabinets.

- 1 transportable cabinet
- 1 wall-mounted antenna

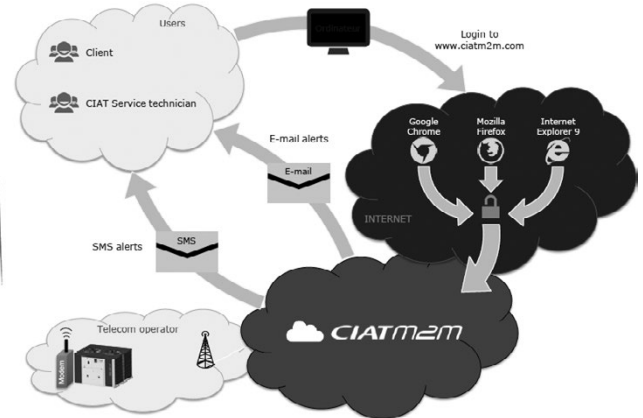

CIATM2M kit contents

- 1 GPRS / 3G modem
- 1 SIM card
- 1 24VDC power supply
- 1 power protection device
- 1 GSM antenna
- Rail mounting
- Enclosed casing to protect the equipment during transport
- Packing box for cable routing (bus, power supply, Ethernet)

Compatibility

Up to 3 machines per CIATM2M kit

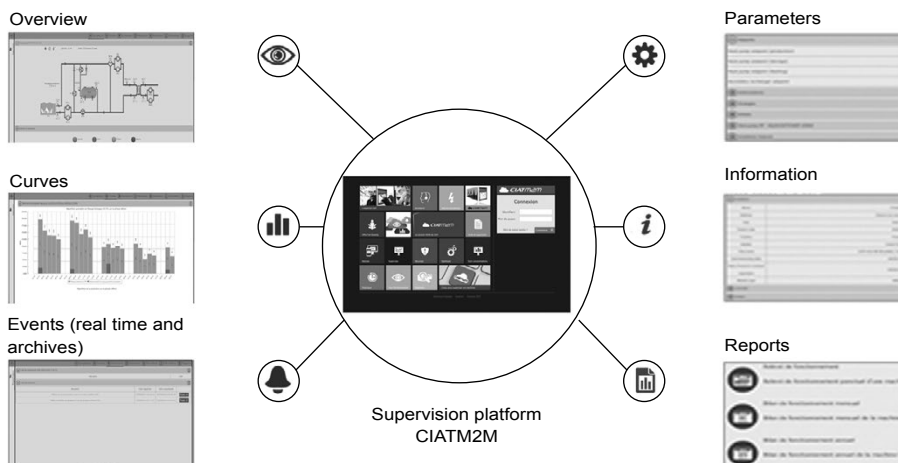

AVAILABLE OPTIONS

Options	Description	Avantages	TD
Corrosion protection, traditional coils	Fins made of pre-treated aluminium (polyurethane and epoxy)	Improved corrosion resistance, recommended for moderate marine and urban environments	•
XtraFan	Fans with 100 Pa maximum available pressure. Each fan equipped with a connection flange & sleeves allowing the connection to the ducting system.	Ducted fan discharge, optimised temperature control, based on the operating conditions and system characteristics	TD 100 to 300
Low Noise	Aesthetic and sound absorbing compressor enclosure	Noise level reduction by 1 to 2 dB(A)	•
Xtra Low Noise	Acoustic compressor enclosure and low-speed fans	Noise emission reduction at reduced fan speed	TD 100 to 300
Soft Starter	Electronic starter on each compressor	Reduced start-up current	•
Hydraulic module frost protection	Electric heater on the hydraulic module	hydraulic module frost protection at low outside temperatures down to -20°C	•
Master/slave operation	Unit equipped with supplementary water outlet temperature sensor kit to be field-installed allowing master/slave operation of two units connected in parallel	Optimised operation of two units connected in parallel operation with operating time equalisation	•
LON gateway	Two-directional communication board complying with Lon Talk protocol	Connects the unit by communication bus to a building management system	•
Bacnet over IP	Two-directional high-speed communication using BACnet protocol over Ethernet network (IP)	Easy and high-speed connection by Ethernet line to a building management system. Allows access to multiple unit parameters	•
Compliance with Russian regulations	EAC certification	Compliance with Russian regulations	•
Condenser screw connection sleeves kit	Condenser inlet/outlet screw connection sleeves	Allows unit connection to a screw connector	•
M2M supervision (accessory)	Monitoring solution which allows customers to track and monitor their equipment remotely in real time	Real-time expert technical support to improve equipment availability and reports at customer hand to monitor and optimize operating equipment.	•
Anti-vibration mounts	Elastomer antivibratils mounts to be place under the unit (Material classified B2 fire class according to DIN 4102).	Isolate unit from the building, avoid transmission of vibration and associate noise to the buiding. Must be used in conjunction with a flexible connection on the water side	•
Condenser flexible sleeves connection	Flexibles connections on the condenser water side	Easy to install. Limits the transmission of vibrations to the water network	•
Set point adjustment by 4-20mA signal	Connections enabling a 4-20 mA signal input	Simplified energy management, enabling the setpoint to be set by a 4-20 mA external signal	•

• ALL MODELS

Refer to the selection tool to find out which options are not compatible.

SEASONAL PERFORMANCES IN HEATING MODE

The European Ecodesign directive takes into account the product's environmental impact throughout its life cycle. It defines the mandatory energy efficiency requirements for water chillers and heat pumps.

Products that do not meet the energy efficiency requirements set by the new directive will gradually be phased out of the market, forcing manufacturers to develop and offer more efficient products.

Like the ESEER relating to water chillers, the new seasonal coefficient of performance (SCOP) resulting from this new European directive is used to evaluate the energy efficiency of heat pumps. Until now, only the COP has been used to measure energy efficiency in heating mode.

The COP was exclusively calculated using a single measuring point, and only took into account operation at full load, which did not represent the efficiency of the heat pump over an entire heating season.

The purpose of the SCOP is to characterise the seasonal efficiency of the heat pump by taking into account the efficiency at partial load and full load established for several outdoor temperatures. The SCOP is the ratio between the building's annual heating demand and the annual electricity consumption of the heating system. It is measured in accordance with standard EN14825 based on an average reference climate that takes into account several reference temperatures between -10°C and +16°C

■ Primary energy evaluation

In order to compare the energy efficiency of products using different energy sources, the Ecodesign directive introduced a new seasonal energy efficiency calculation known as η_s (Greek letter eta followed by the letter "s" for seasonal) and expressed as a percentage. For heat pumps, the SCOP (final energy) value is transposed to η_s (primary energy) by taking into account a conversion coefficient of 2.5 which corresponds to the average efficiency of the electrical production and various corrections for the responsiveness of the regulation system ($i = 3$ for air-to-water heat pumps).

The minimum seasonal efficiency requirements to be met by air-to-water heat pumps, set by the standard, are as follows:

$$\eta_s (\%) = \frac{(\text{SCOP}(\text{kW/kW}) \times 100)}{2,5} - \sum i \text{ corrections}$$

$\eta_s = 100\%$, which is a minimum SCOP of 2.83 valid from September 26 2017.

AQUACIAT^{CALEO} complies with the Ecodesign 2017 European directive across the entire range.

HYDRAULIC MODULE

■ The “ALL IN ONE” solution

The PLUG & COOL solution offered by the AQUACIAT^{CALEO}

The hydraulic module, which is standard machine equipment, contains all the hydraulic circuit components needed for the system to operate correctly:

- Variable speed single pump
- Water temperature and pressure sensors
- Water filter
- Safety valve
- Drain circuit
- Air bleed valve
- Frost protection (option)

The components in the hydraulic system are carefully selected and factory assembled and tested to make the installation of the units simple and economical.

This ensures conditioning times, implementation times and space requirements are kept to a minimum.

■ AQUACIAT^{CALEO} hydraulic module diagram

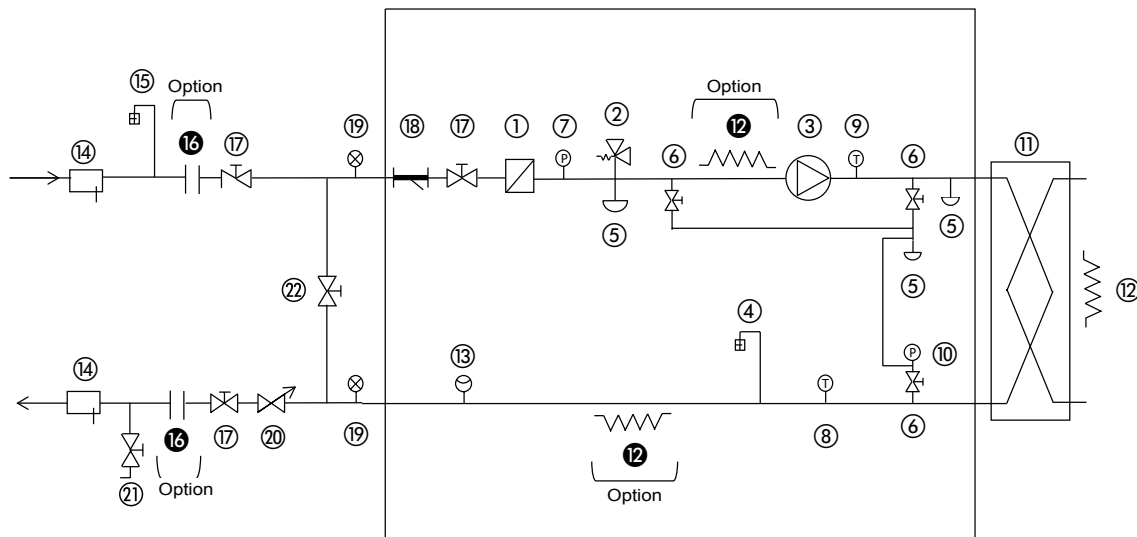

Key

Components of the unit and hydraulic module

- 1 Screen filter (particle size of 1.2 mm)
 - 2 Relief valve
 - 3 Single operating pressure pump
 - 4 Air bleed valve
 - 5 Water drain tap
 - 6 Shut-off valve
 - 7 Pressure sensor
- Notes:
- Provides pressure information for the pump inlet (see Control manual)
- 8 Temperature sensor
- Note:
- Provides temperature information for the water type heat exchanger outlet (see Control manual)
- 9 Temperature sensor
- Note:
- Provides temperature information for the water type heat exchanger inlet (see Control manual)
- 10 Pressure sensor
- Note:
- Provides pressure information for the water type heat exchanger outlet (see Control manual)
- 11 Plate heat exchanger
 - 12 Heater or heat trace cable for antifreeze protection (Option)
 - 13 Water type heat exchanger flow rate sensor

System components

- 14 Pocket
 - 15 Air bleed valve
 - 16 Flexible connection (Option)
 - 17 Shut-off valve
 - 18 800 µm screen filter
 - 19 Pressure gauge
 - 20 Water flow rate control valve
- Note: not required if hydraulic module with variable speed pump
 - 21 Charge valve
 - 22 Bypass valve for frost protection (if shut-off valves are closed (item 19) during winter)

----- Hydraulic module

Notes:

 - The system must be protected against frost.
 - The unit's water type heat exchanger is protected against freezing using electric heaters, fitted as standard
 - The unit's hydraulic module can be protected against freezing using heaters and heat trace cables (option 12 fitted in the factory)

The pressure sensors are assembled on connections without schraeder. Depressurise and drain the system before any work.

VARIABLE FLOW PUMP

■ Description

AQUACIAT^{CALEO} is equipped as standard with a variable speed pump which saves you energy by adjusting the electrical consumption of one pump to the actual requirements of a hydraulic system, in particular for oversized installations.

■ Simple to use

The “variable speed pump” is fully integrated on the machine, with full protection, and, as it is installed outdoors, there is no need for any work in the machine room.

The assembly is factory-fitted and pre-set on the unit; it is therefore quick to install and reduces the cost of work, in particular because there is no water flow control valve on the unit’s outlet.

The ability to adjust the water flow to your requirements means that the pump pressure can be adapted precisely to the actual pressure drop on the system when it is started up on-site.

■ Operating principle

- Operation at full load

A regulator, with a direct display of the flow rate and pressure on the Connect Touch screen, enables one pump (pump A in the example below) to be adapted, by lowering its pressure P1 to the requirements of system P2, to obtain the optimal water flow rate setpoint. Electricity bills relating to the pump’s consumption are reduced proportionately; this means you will see a return on investment (ROI) in only a few years, compared with the same fixed speed pump equipped with a simple flow control valve.

- Operation at partial load

There are three operating modes for partial load:

• Fixed speed

The control ensures the pump continuously runs at a constant speed, based on the capacity of the compressor(s). When the compressor is powered off, the Connect Touch “standby” function manages the electrical power consumed by the pump by reducing its speed to the minimum.

This provides energy savings of around 33%

• Variable flow rate: Constant regulation of the pressure difference

The control continuously acts on the pump speed to ensure a constant pressure difference (delta P). This solution is suitable for installations with two-way valves. This control mode is used to ensure a uniform supply in each hydraulic circuit to make sure that each terminal unit operates at a satisfactory pressure

• Variable flow rate: Constant regulation of the temperature difference

The regulation maintains a constant temperature difference whatever the load rate of the unit by reducing the flow rate to the minimum acceptable limit. This control mode is suitable for most comfort applications.

This provides energy savings of around 66% for the pump in each of these last two operating modes

■ SOFT START

A SOFT START function prevents any current peaks when the pump is started up to protect the electrical system, thereby limiting the building’s electricity use at peak times and ensuring the smooth operation of the pipework.

■ STANDBY function

Lowering the speed when the compressors are on standby reduces the water flow rate to ensure the water loop is perfectly homogenised and the control temperature sensors are well irrigated. This reduces the pump’s electricity consumption by around 80% during standby periods, which represents a significant proportion of the machine’s normal operating time, in particular for air conditioning applications.

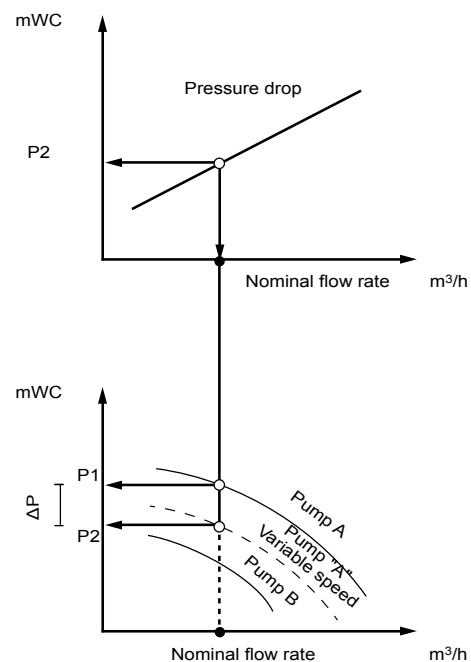

TECHNICAL CHARACTERISTICS

AQUACIAT ^{CALEO} TD			70	80	100	120	150	200	300		
Heating											
Standard unit Full load performances*	HA1	Nominal capacity	kW	20,6	25,9	32,3	43,4	51,5	64,7	102,0	
		COP	kW/kW	4,11	4,02	4,04	4,27	4,32	3,97	4,24	
	HA2	Nominal capacity	kW	20,6	25,5	32,0	43,0	51,6	66,6	102,0	
		COP	kW/kW	3,46	3,37	3,35	3,56	3,64	3,42	3,58	
	HA3	Nominal capacity	kW	20,7	25,0	31,6	42,7	52,2	67,9	102,0	
		COP	kW/kW	2,99	2,91	2,89	3,10	3,16	3,00	3,12	
	HA4	Nominal capacity	kW	21,0	24,6	31,3	42,6	53,3	68,0	103,0	
		COP	kW/kW	2,50	2,43	2,42	2,60	2,66	2,52	2,64	
	Standard unit Seasonal energy efficiency**	HA1	SCOP _{30/35°C}	kW/kW	3,45	3,44	3,53	3,51	3,62	3,47	3,51
			η _s heat _{30/35°C}	%	135	134	138	138	142	136	137
			P _{rated}	kW	14,8	19,2	32,8	44,5	55,9	74,1	108,7
		HA3	SCOP_{47/55°C}	kW/kW	2,92	2,94	2,97	3,00	3,08	2,99	3,15
η_s heat_{47/55°C}			%	114	115	116	117	120	117	123	
P _{rated}			kW	15	19	31	43	54	63	94	
Energy labelling			A+	A+	A+	A+	A+	A+	-		
Operating weight⁽¹⁾											
Unit + hydraulic module option		kg	362	418	435	555	579	919	1039		
Sound levels											
Standard unit											
Sound power ⁽²⁾		dB(A)	77	78	83	82	84	84	85		
Sound pressure at 10m ⁽³⁾		dB(A)	46	46	51	51	53	52	53		
Unit + Low Noise option											
Sound power ⁽²⁾		dB(A)	75	76	80	80	80	82	82		
Sound pressure at 10m ⁽³⁾		dB(A)	44	44	49	48	49	50	51		
Unit + Xtra Low Noise option											
Sound power ⁽²⁾		dB(A)	NA	NA	76	76	77	79	79		
Sound pressure at 10m ⁽³⁾		dB(A)	NA	NA	45	45	45	47	47		
Dimensions											
Length		mm	1110			1114		2273			
Depth		mm	1327			2100		2100			
Height		mm	1440			1440		1440			
Compressor			Hermetic Scroll 48.3 r/s								
Quantity			1	1	1	1	1	2	2		
Number of power stages			1	1	1	1	1	2	2		

- * In accordance with standard EN14511-3:2018.
- * In accordance with standard EN14825:2018, average climate.
- HA1 Heating mode conditions: Water heat exchanger water entering/leaving temperature 30°C/35°C, outside air temperature tdb/twb = 7°C db/6°C wb, evaporator fouling factor 0 m2. kW/W
- HA2 Heating mode conditions: Water heat exchanger water entering/leaving temperature 40°C/45°C, outside air temperature tdb/twb = 7°C db/6°C wb, evaporator fouling factor 0 m2. kW/W
- HA3 Heating mode conditions: Water heat exchanger water entering/leaving temperature 47°C/55°C, outside air temperature tdb/twb = 7°C db/6°C wb, evaporator fouling factor 0 m2. kW/W
- HA4 Heating mode conditions: Water heat exchanger water entering/leaving temperature 55°C/65°C, outside air temperature tdb/twb = 7°C db/6°C wb, evaporator fouling factor 0 m2. kW/W
- η_s heat_{30/35°C} & SCOP_{30/35°C} Values calculated in accordance with EN 14825:2018
- η_s heat_{47/55°C} & SCOP_{47/55°C} Values in bold comply with Ecodesign Regulation (EU) No. 813/2018 for heating application
- Not applicable
- (1) Weight given as a guide. Please refer to the unit nameplate.
- (2) In dB ref=10-12 W, 'A' weighted. Declared dual-number noise emission values in accordance with ISO 4871 with an associated uncertainty of +/-2dB(A). Measured in accordance with ISO 9614-1 and certified by Eurovent.
- (3) In dB ref 20 μPa, 'A' weighted. Declared dual-number noise emission values in accordance with ISO 4871 with an associated uncertainty of +/-2dB(A). For information, calculated from the sound power Lw(A).



Eurovent certified values

TECHNICAL CHARACTERISTICS

AQUACIAT ^{CALEO} TD		70	80	100	120	150	200	300
Refrigerant		R407C PRG = 1800 following AR4						
Charge	kg	8	8,8	9,7	10	13,2	22	26,5
	tCO ₂ eq	14,2	15,6	17,2	17,7	23,4	39,0	47,0
Oil		POE - EMKARATE RL32-3 MAF						
Charge	l	1,9	4,1	4,1	4,1	4,1	8,2	8,2
Control		Connect Touch						
Minimum capacity	%	100	100	100	100	100	50	50
Condenser		Direct expansion, plate heat exchanger						
Water volume	l	4,9	6,4	8,2	9,6	12,1	16,4	22,7
Max. water-side operating pressure with hydraulic module	kPa	400	400	400	400	400	400	400
Fan		Axial with rotating impeller. Flying-Bird 4						
Quantity	1	1	1	1	1	2	2	2
Total air flow (high speed)	l/s	3770	3748	3736	4035	4036	7479	8072
Standard rotation speed	r/s	12	12	12	12	12	12	12
Rotation speed with Xtrafan	r/s	-	-	16	16	16	16	16
Evaporator		Grooved copper tube and aluminium fins						
Hydraulic module		Pump. viciaulic screen filter. valve. purge valves (water and air). cavitation pressure sensor						
Water connections		Viciaulic						
Connections	inch	1" 1/4	1" 1/4	1" 1/2	1" 1/2	1" 1/2	2"	2"
External diameter	mm	42,4	42,4	48,3	48,3	48,3	60,3	60,3
Chassis paint colour		Colour code RAL 7035 and RAL7024						

ELECTRICAL SPECIFICATIONS

AQUACIAT ^{CALEO} TD		70	80	100	120	150	200	300
Power circuit								
Nominal voltage	V-ph-Hz	400-3-50						
Voltage range	V	360-440						
Control circuit supply		24 V via internal transformer						
Maximum start-up current (Un)⁽¹⁾								
Standard unit	A	104	102	130	172	203	158	243
Unit with soft starter option	A	56	54	69	92	103	97	144
Unit power factor at maximum capacity⁽²⁾		0,82	0,82	0,83	0,87	0,87	0,83	0,87
Max. operating input power⁽²⁾	kW	10	12	16	21	25	32	48
Nominal unit current draw⁽³⁾	A	14	16	20	25	30	42	57
Maximum unit current draw (Un)⁽⁴⁾	A	17	21	27	35	41	56	79
Max. current draw (Un-10%)⁽⁵⁾	A	18	22	29	38	45	60	86

- (1) Maximum instantaneous starting current (maximum operating current of the smallest compressor + fan current + locked rotor current of the largest compressor).
 (2) Input power, compressors + fans, at the unit operating limits (saturated suction temperature: 10°C, saturated condensing temperature: 65°C) and nominal voltage of 400 V (data given on the unit nameplate).
 (3) Standardised EUROVENT conditions: condenser entering/leaving water temperature = 40/45°C, outside air temperature db/wb = 7°C/6°C.
 (4) Maximum unit operating current at maximum unit input power and 400 V (values given on the unit's nameplate).
 (5) Maximum unit operating current at maximum unit input power and 360 V.

■ Short circuit current withstand capability (TN system⁽¹⁾)

AQUACIAT ^{CALEO} TD - Standard unit (disconnect switch)		70	80	100	120	150	200	300
Value without upstream protection								
Short time (1s) assigned current (I _{cw})	kA rms	0,6	0,6	0,6	1,26	1,26	1,26	2
Allowable peak assigned current (I _{pk})	kA pk	4,5	4,5	4,5	6	6	6	10
value with upstream protection by circuit breaker								
Conditional short circuit assigned current (I _{cc})	kA rms	5,4	7	7	7,7	7,7	6,1	10
Circuit breaker - Compact range type		32	40	40	50	63	80	100
Reference number ⁽²⁾		5SY6332-7	5SY6340-7	5SY6340-7	5SY4350-7	5SY4363-8	5SP4380-7	5SP4391-7
Value with upstream protection by fuses								
Conditional short circuit assigned current (I _{cc})	kA rms	17	50	50	50	50	14,5	22
Fuse (gL/gG)		40	40	40	63	63	80	125

- (1) Type of system earthing
 (2) If another current limitation protection system is used, its time-current and thermal constraints (I²t) trip characteristics must be at least equivalent to those of the recommended circuit breaker.
 The short circuit current stability values given above are for the TN system.

XTRAFAN OPERATING PRESSURE VENTILATION

Models 100 to 300 in the AQUACIAT^{CALEO} range can be equipped with optional operating pressure fans.

■ **Functions**

The operating pressure fan guarantees particularly flexible installation conditions, including:

- The possibility of installation in a small space, for example a walled terrace in which only a ducted air supply enables use without recycling or mixing of the air at the coil suction intake.
- Installation in an urban area in which noise is a particular issue, where operation is only possible by adapting a sound trap to the air supply.

For this reason, fans more powerful than those on standard units are installed, thus enabling a maximum static operating pressure of 100 Pa to be obtained.

■ **Precautions for installation**

On-site installation of a heat pump, particularly in a machine room, requires certain technical precautions. For example, the evacuation of condensates specific to these units, including at very low outdoor temperatures.

During defrosting cycles, reversible units are liable to discharge a large amount of water onto the ground, which must be drained, as well as steam from the fan discharge which can damage the air discharge ducts. The ground supporting the unit must be perfectly watertight and capable of collecting and draining the defrosted water, including during freezing periods. It is recommended that the unit is raised by approximately 300 mm.

If an air discharge duct is installed on site, its weight must not be supported by the roof of the unit. Each fan must be connected independently

■ **Fan discharge connection**

Each fan is equipped with a connection flange and a flexible sleeve connector to allow connection to the ducting system. It is recommended to connect to the air duct using a flexible connector. Failure to follow this recommendation may result in significant vibration or noise being transmitted to the building structure.

INTELLIGENTLY-DESIGNED ACOUSTICS

To comply with the various restrictions on integration, the AQUACIAT^{CALEO} has three sound finish levels enabling it to be easily integrated into a number of zones without causing disruption to users or their neighbours.

■ Basic version

The distinguishing feature of the AQUACIAT^{CALEO} range is its rigorous design incorporating “noiseless” assembly techniques:

- New generation scroll compressors with a continuous scrolling motion to lessen vibrations
- Compressor structure separated from the unit by anti-vibration mounts
- Pipes separated from the unit structure
- Fans made from a synthetic material, with aerodynamic blades offering an optimised profile. Optimised coil-fan combination, the result of many hours of study of the thermal and acoustic properties in our Research and Innovation Centre, to ensure a linear flow of air without turbulence, to limit noise to an acceptable acoustic spectrum.
- The Connect Touch controller automatically adjusts the fan air flow rate according to the outdoor air temperature and the unit’s load rate which enables the sound level to be significantly reduced, particularly at night and mid-season.

■ Low Noise option

In this version, in addition to the basic equipment, the compressors are housed inside noise insulating jackets.

■ Xtra Low Noise option

In this version, the compressors are housed inside noise insulating jackets and the fan rotation speed is reduced whilst ensuring the output and thermal performance remain optimised. This option is available on models 100 to 300.

■ Night mode

The AQUACIAT^{CALEO} has a Night Mode enabling the sound level to be limited at night or when the building is unoccupied (according to the user programming) by controlling the output and the fan rotation speed.

The installation of a variable-speed pump enables the sound level of the pump function to be reduced by adjusting the pump speed to what is strictly necessary. The soft start improves the signature and reduces nuisance noise.

With all these benefits and its three acoustic finish levels (Standard, Low Noise and Xtra Low Noise), the AQUACIAT^{CALEO} can be integrated into any site, ensuring any constraints in terms of the sound environment can be met.

SOUND LEVELS

Standard version

■ Sound power levels ref 10^{-12} W \pm 3 dB (L_w)

At nominal EN 14511-3: 2013 operating conditions - Heating mode

AQUACIAT ^{CALEO} TD	SOUND POWER LEVEL SPECTRUM (dB)						Overall power level dB(A)
	125 Hz	250 Hz	500 Hz	1000 Hz	2000 Hz	4000 Hz	
070	67	70	72	72	69	71	77
080	65	69	72	73	70	71	78
100	83	81	80	78	75	71	83
120	84	81	82	76	75	67	82
150	87	81	81	76	78	76	84
200	85	84	82	79	75	69	84
300	82	86	82	78	78	70	85

■ Sound pressure levels ref 2×10^{-5} Pa \pm 3 dB (L_p)

Measurement conditions: free field, 10 metres from machine, 1.50 metres above floor level, directivity 2

AQUACIAT ^{CALEO} TD	SOUND PRESSURE SPECTRUM (dB)						Overall pressure level dB(A)
	125 Hz	250 Hz	500 Hz	1000 Hz	2000 Hz	4000 Hz	
070	35	38	41	41	37	40	46
080	33	38	41	41	39	40	46
100	52	50	48	46	43	40	51
120	52	49	50	45	43	36	51
150	55	49	49	45	47	44	53
200	53	52	51	48	43	37	52
300	51	54	50	47	46	39	53

NB: Sound pressure levels depend on the installation conditions of each system. As such, the levels listed here are given for information only. Only the sound power levels are comparable and certified.

SOUND LEVELS

Standard Version LOW NOISE Option

■ Sound power levels ref 10^{-12} W ± 3 dB (L_w)

At nominal EN 14511-3: 2013 operating conditions - Heating mode

AQUACIAT ^{CALEO} TD	SOUND POWER LEVEL SPECTRUM (dB)						Overall power level dB(A)
	125 Hz	250 Hz	500 Hz	1000 Hz	2000 Hz	4000 Hz	
070	65	68	72	71	67	67	75
080	63	68	72	71	69	67	76
100	82	80	78	76	70	64	80
120	82	80	80	74	69	61	80
150	86	81	79	75	71	67	80
200	83	82	80	77	71	63	82
300	82	84	81	77	72	64	82

■ Sound pressure levels ref 2×10^{-5} Pa ± 3 dB (L_p)

Measurement conditions: free field, 10 metres from machine, 1.50 metres above floor level, directivity 2

AQUACIAT ^{CALEO} TD	SOUND PRESSURE SPECTRUM (dB)						Overall pressure level dB(A)
	125 Hz	250 Hz	500 Hz	1000 Hz	2000 Hz	4000 Hz	
070	34	36	40	39	36	35	44
080	32	36	40	40	37	35	44
100	50	49	47	44	39	32	49
120	50	48	48	42	38	29	48
150	55	49	47	43	39	35	49
200	51	50	48	45	39	31	50
300	50	52	50	45	40	32	51

NB: Sound pressure levels depend on the installation conditions of each system. As such, the levels listed here are given for information only. Only the sound power levels are comparable and certified.

SOUND LEVELS

Standard Version XTRA LOW NOISE Option

■ Sound power levels ref 10^{-12} W \pm 3 dB (L_w)

Operating conditions with outdoor temperature $>20^{\circ}\text{C}$ - Heating mode

AQUACIAT ^{CALEO} TD	SOUND POWER LEVEL SPECTRUM (dB)						Overall power level dB(A)
	125 Hz	250 Hz	500 Hz	1000 Hz	2000 Hz	4000 Hz	
100	75	78	72	72	68	63	76
120	82	77	75	69	66	59	76
150	84	77	74	69	67	66	77
200	78	81	77	74	68	61	79
300	79	82	77	71	69	62	79

■ Sound pressure levels ref 2×10^{-5} Pa \pm 3 dB (L_p)

Measurement conditions: free field, 10 metres from machine, 1.50 metres above floor level, directivity 2

AQUACIAT ^{CALEO} TD	SOUND PRESSURE SPECTRUM (dB)						Overall pressure level dB(A)
	125 Hz	250 Hz	500 Hz	1000 Hz	2000 Hz	4000 Hz	
100	44	46	40	41	36	31	45
120	50	46	44	37	34	28	45
150	52	46	43	37	36	34	45
200	46	49	45	42	36	29	47
300	47	50	46	40	37	30	47

NB: Sound pressure levels depend on the installation conditions of each system. As such, the levels listed here are given for information only. Only the sound power levels are comparable and certified.

SOUND LEVELS

Standard Version Xtrafan option

■ Sound power levels ref 10^{-12} W ± 3 dB (L_w)

Radiated + suction, ducted fans

At nominal EN 14511-3: 2013 operating conditions - Heating mode

AQUACIAT ^{CALEO} TD	POWER LEVEL SPECTRUM (dB) - Radiated						Overall power level dB(A)
	125 Hz	250 Hz	500 Hz	1000 Hz	2000 Hz	4000 Hz	
100	84	86	86	85	79	73	88
120	85	85	86	85	78	71	88
150	86	85	86	84	80	76	89
200	86	88	89	87	80	73	91
300	86	89	89	87	82	74	91

■ Sound pressure levels ref 2×10^{-5} Pa ± 3 dB (L_p)

Radiated + suction, ducted fans

Measurement conditions: free field, 10 metres from machine, 1.50 metres above floor level, directivity 2

AQUACIAT ^{CALEO} TD	SOUND PRESSURE SPECTRUM (dB)						Overall pressure level dB(A)
	125 Hz	250 Hz	500 Hz	1000 Hz	2000 Hz	4000 Hz	
100	52	54	54	53	47	42	57
120	54	54	54	53	47	39	56
150	54	54	54	53	49	45	57
200	54	57	57	56	49	41	59
300	54	58	57	56	50	42	59

■ Sound power levels ref 10^{-12} W ± 3 dB (L_w) - Ducted fans outlet

AQUACIAT ^{CALEO} TD	POWER LEVEL SPECTRUM (dB) - Radiated						Overall pressure level dB(A)
	125 Hz	250 Hz	500 Hz	1000 Hz	2000 Hz	4000 Hz	
100	75	78	72	72	68	63	76
120	82	77	75	69	66	59	76
150	84	77	74	69	67	66	77
200	78	81	77	74	68	61	79
300	79	82	77	71	69	62	79

NB: Sound pressure levels depend on the installation conditions of each system. As such, the levels listed here are given for information only. Only the sound power levels are comparable and certified.

SYSTEM WATER VOLUME - EVAPORATOR WATER FLOW RATE

The Connect Touch controller is equipped with anticipation logic making it highly flexible in adjusting operation to parameter drift, particularly on hydraulic systems with low water volumes. By adjusting compressor runtimes, it prevents short-cycle protection cycles from starting and, in most cases, eliminates the need for a buffer tank.

Note: The minimum volumes of chilled water are calculated for EUROVENT rated conditions:

Heating mode

- Hot water temperature = 40°C/45°C

- Outdoor air temperature = 7°C

This value is applicable for most air conditioning applications (unit with fan coil units)

Note: For installations running with a low volume of water (unit with air handling unit) or for industrial processes, the buffer tank is essential.

■ Minimum system water volume and water type heat exchanger flow rate

AQUACIAT ^{CALEO} TD	070	080	100	120	150	200	300
Minimum system water volume, air conditioning application (litres)	105	125	160	220	270	204	309
Min ⁽¹⁾ / max ⁽²⁾ water-cooled heat exchanger flow rate without hydraulic module (l/s)	0,5 / 1,8	0,6 / 2,4	0,7 / 3,1	1,0 / 3,8	1,2 / 4,6	1,6 / 5,9	2,3 / 8,5
Water exchanger flow rate with low pressure hydraulic module (l/s)	Min ⁽³⁾ / max single	0,6 / 1,8	0,7 / 2,4	1,0 / 2,8	1,2 / 3,8	1,6 / 4,6	2,3 / 5,9

(1) Minimum flow rate for maximum allowable water temperature difference conditions (10K)

(2) Maximum flow rate for a pressure drop of 100 kPa in the plate heat exchanger

(3) Minimum factory flow rate setting according to the type of pump

NOTE: For the Buffer Tank Module option, the volume of the tank must be taken into account (250 litres)

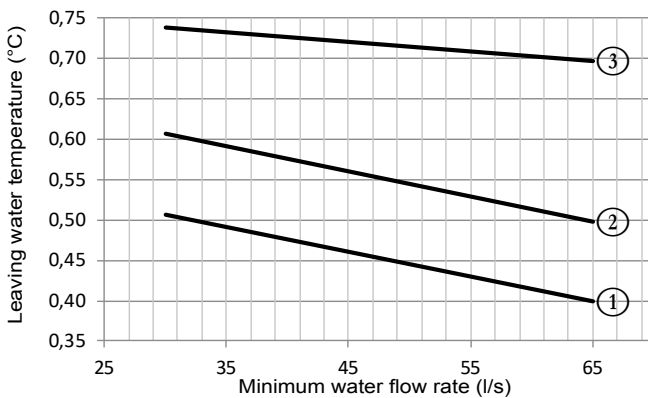

- ① Aquaciat Caléo TD 070
- ② Aquaciat Caléo TD 080
- ③ Aquaciat Caléo TD 100

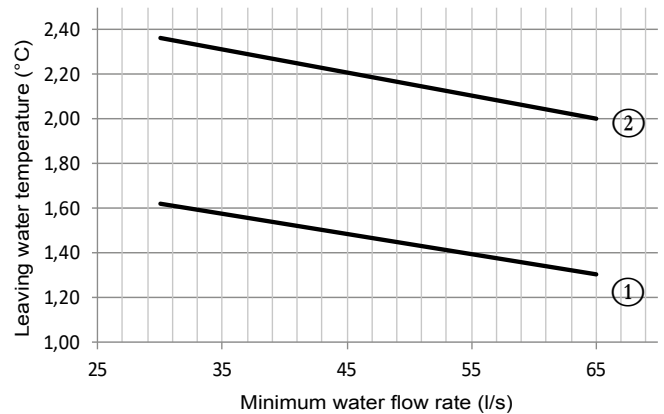

- ① Aquaciat Caléo TD 120
- ② Aquaciat Caléo TD 150

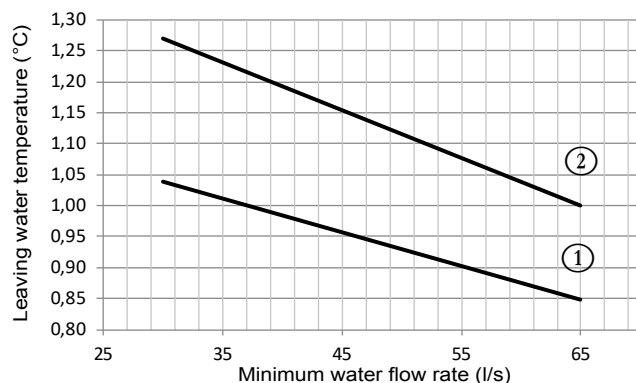

- ① Aquaciat Caléo TD 200
- ② Aquaciat Caléo TD 300

OPERATING RANGE

AQUACIAT^{CALEO} units have a broad field of application, enabling them to meet a range of heating requirements in the most varied of climates.

The AQUACIAT^{CALEO} can be used for all traditional heating applications in sectors as varied as collective housing, hotels, shopping centres and offices.

■ Operating limits of the TD heat pump

Multi-climate

Due to its design, the AQUACIAT^{CALEO} is a great solution for all heating applications, whatever the climate. Water heated to +65°C is guaranteed, even for outdoor temperatures of -10°C

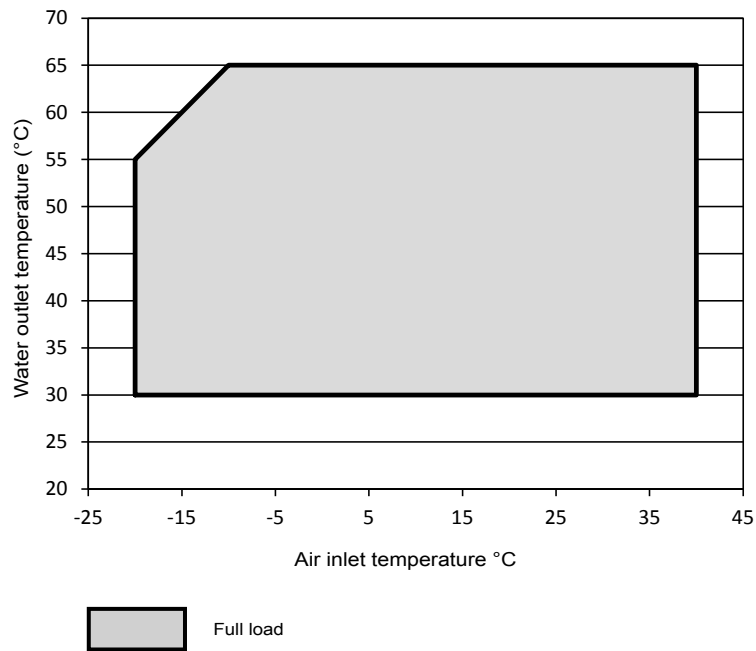

HYDRAULIC SPECIFICATIONS

■ Available static system pressure

Units with hydraulic module (variable speed single pump at 50 Hz)

Data applicable for:

- Pure water at 20°C
- Refer to the section "Evaporator water flow rate" for the minimum and maximum water flow rate values
- If a glycol/water mix is used, the maximum water flow rate is reduced.

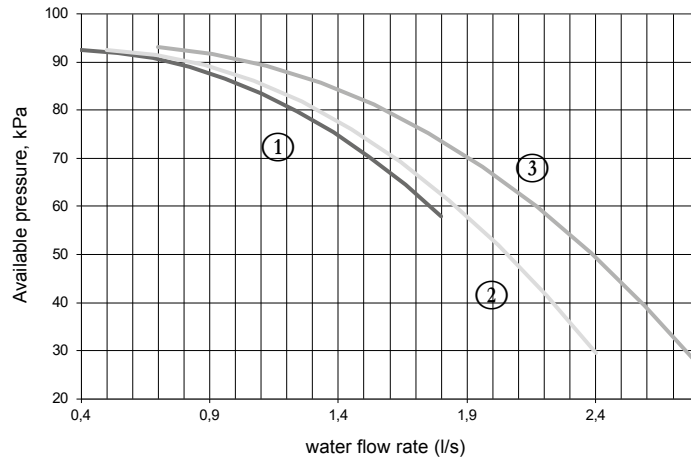

- ① 070
- ② 080
- ③ 100

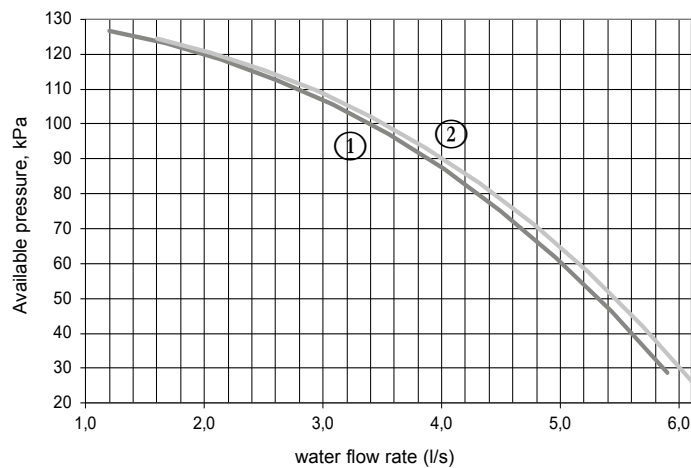

- ① 200
- ② 300

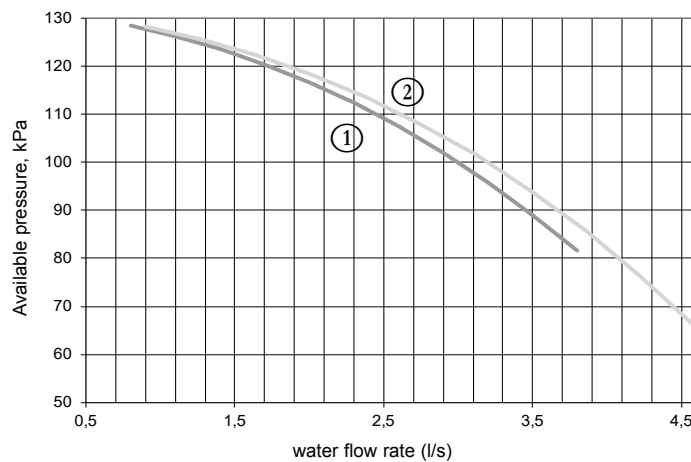

- ① 120
- ② 150

DIMENSIONS

■ AQUACIAT^{CALEO} TD 70 to 100

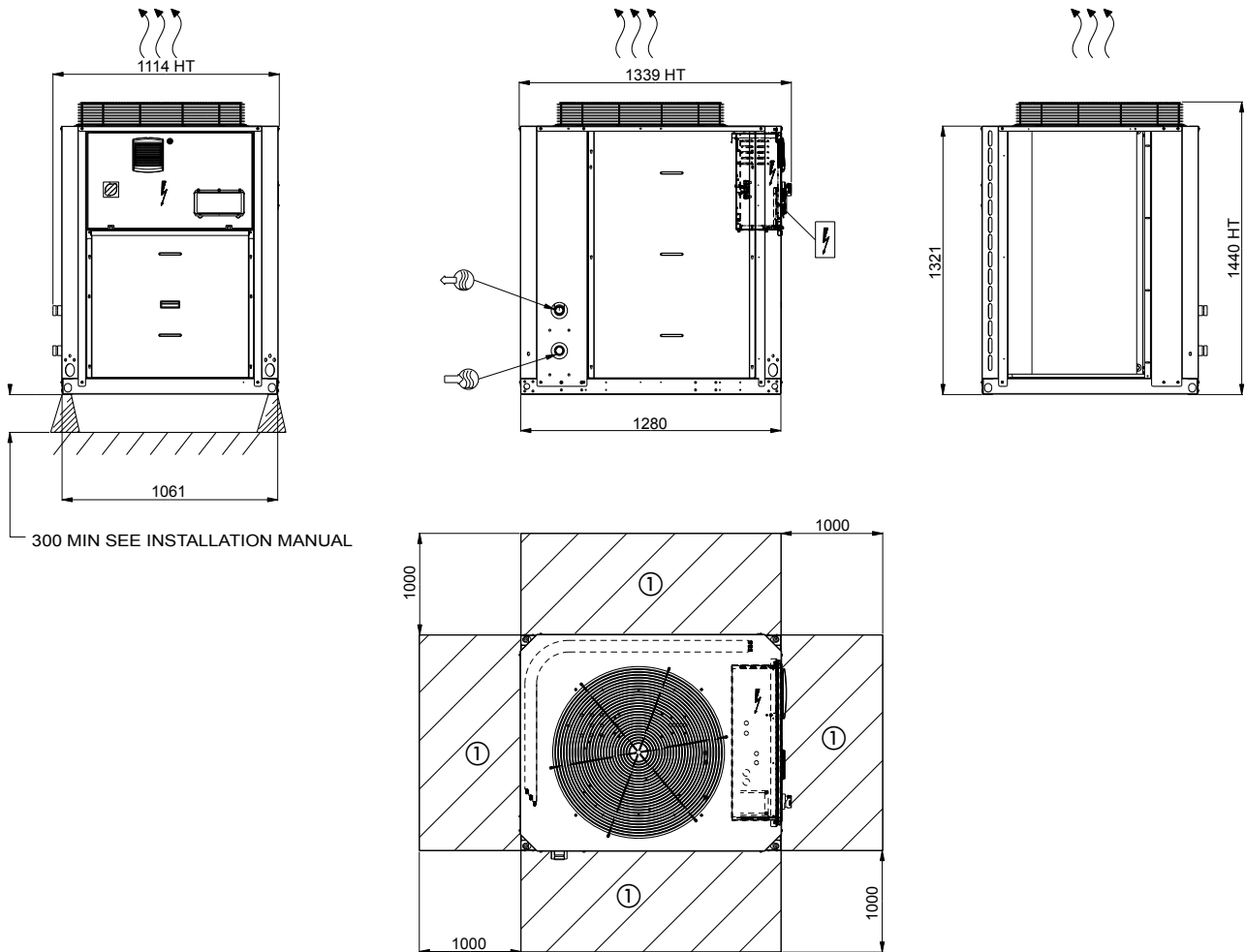

Key

Dimensions en mm

- ① Clearance required for maintenance and air flow
- Water inlet
- Water outlet
- Air outlet, do not obstruct
- Electrical cabinet

NOTES :

Non-contractual drawings.

When designing a system, refer to the certified dimensional drawings provided with the unit or available on request.

Please refer to the certified dimensional drawings for the positioning of the fixing points, weight distribution points and centre of gravity coordinates.

DIMENSIONS

■ AQUACIAT^{CALEO} TD 120 to 150

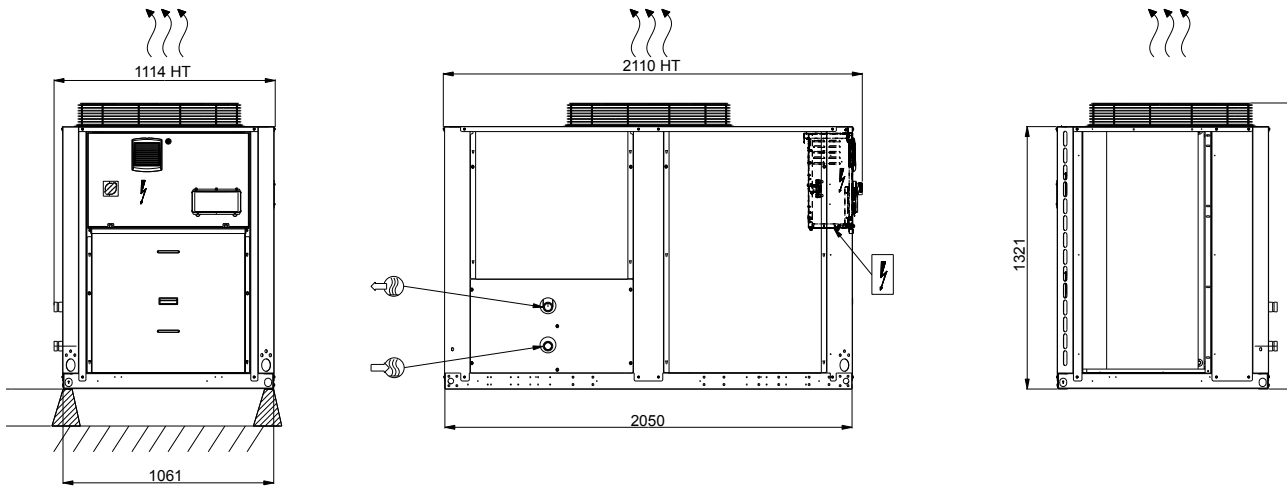

300 MIN SEE INSTALLATION MANUAL

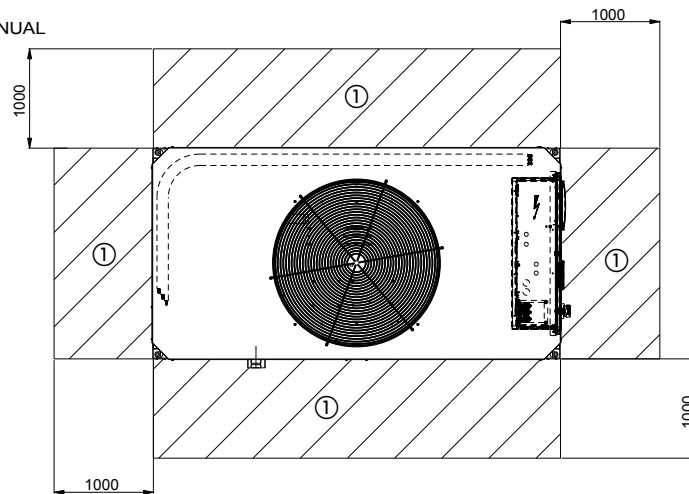

Key

Dimensions en mm

- ① Clearance required for maintenance and air flow
- Water inlet
- Water outlet
- Air outlet, do not obstruct
- Electrical cabinet

NOTES :

Non-contractual drawings.

When designing a system, refer to the certified dimensional drawings provided with the unit or available on request.

Please refer to the certified dimensional drawings for the positioning of the fixing points, weight distribution points and centre of gravity coordinates.

DIMENSIONS

■ AQUACIAT^{CALEO} TD 200 to 300

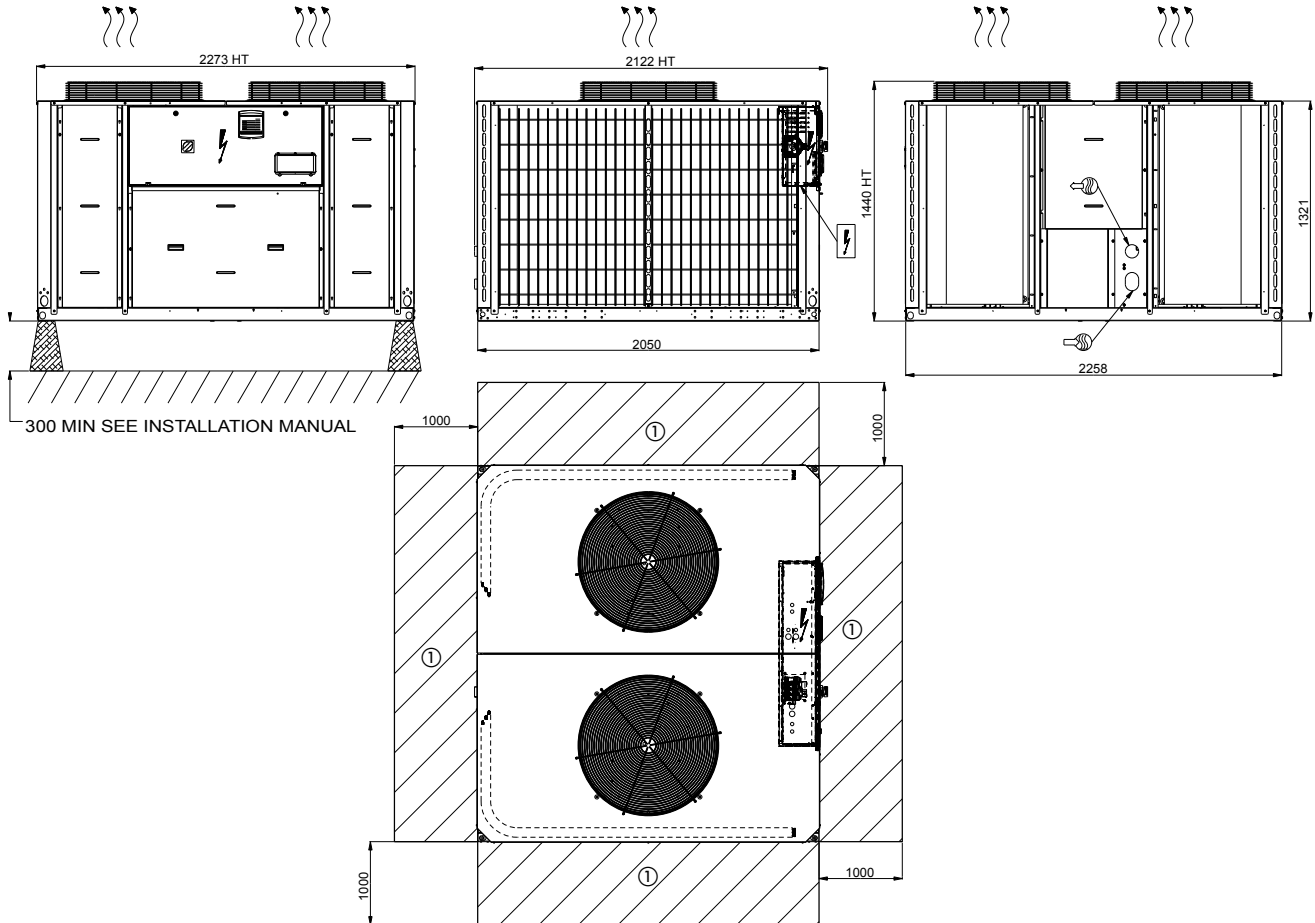

Key

Dimensions en mm

① Clearance required for maintenance and air flow

↻ Water inlet

↻ Water outlet

))) Air outlet, do not obstruct

⚡ Electrical cabinet

NOTES :

Non-contractual drawings.

When designing a system, refer to the certified dimensional drawings provided with the unit or available on request.

Please refer to the certified dimensional drawings for the positioning of the fixing points, weight distribution points and centre of gravity coordinates..

DIMENSIONS

■ AQUACIAT^{CALEO} TD 100 XTRA fan option

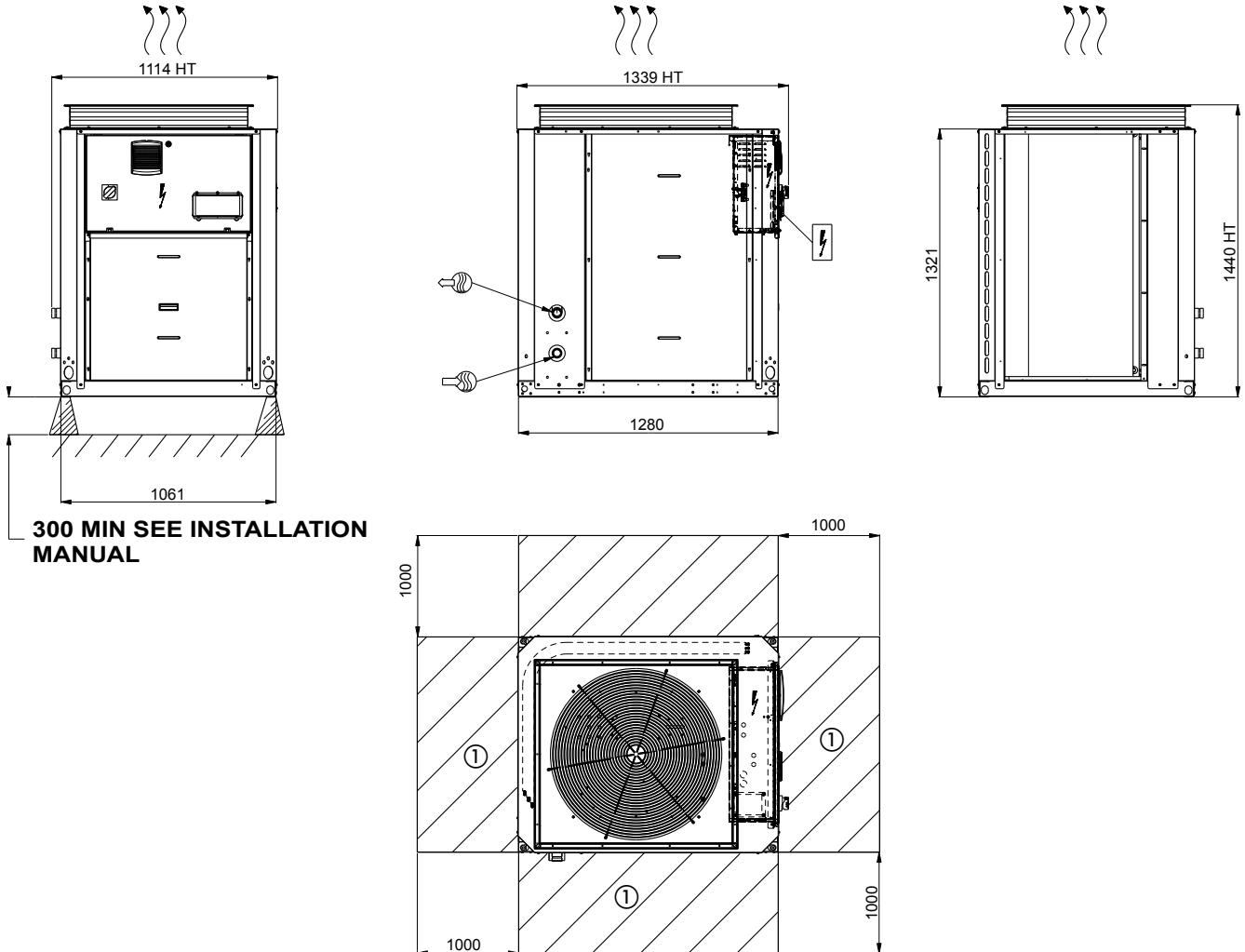

300 MIN SEE INSTALLATION MANUAL

Key

Dimensions en mm

- ① Clearance required for maintenance and air flow
- ↻ Water inlet
- ↻ Water outlet
-))) Air outlet, do not obstruct
- ⚡ Electrical cabinet

NOTES :

Non-contractual drawings.

When designing a system, refer to the certified dimensional drawings provided with the unit or available on request.

Please refer to the certified dimensional drawings for the positioning of the fixing points, weight distribution points and centre of gravity coordinates.

DIMENSIONS

■ AQUACIAT^{CALEO} TD 120 - 150 XTRA fan option

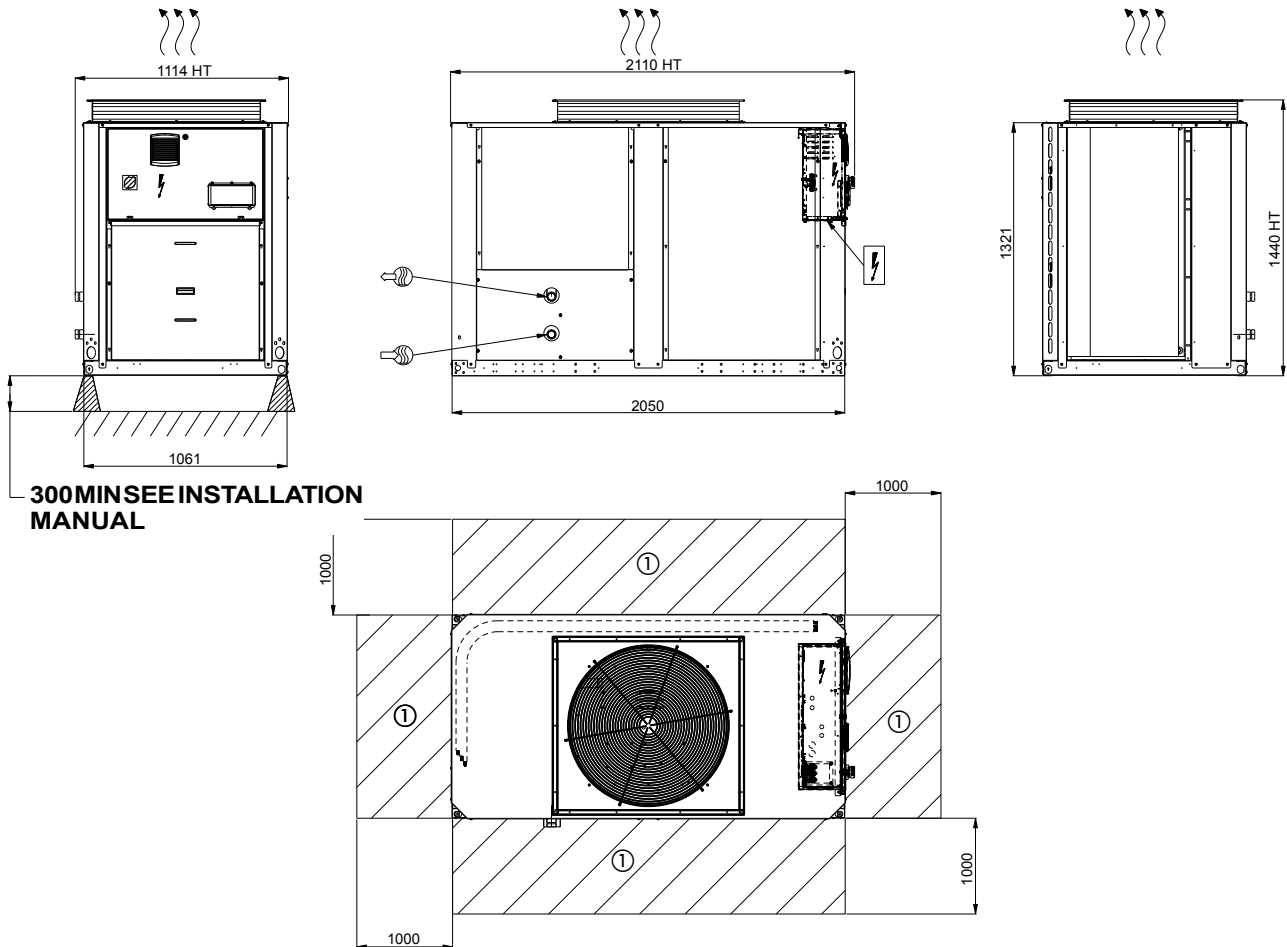

Key

Dimensions en mm

- ① Clearance required for maintenance and air flow
- Water inlet
- Water outlet
- Air outlet, do not obstruct
- Electrical cabinet

NOTES :

Non-contractual drawings.

When designing a system, refer to the certified dimensional drawings provided with the unit or available on request.

Please refer to the certified dimensional drawings for the positioning of the fixing points, weight distribution points and centre of gravity coordinates.

DIMENSIONS

■ AQUACIAT^{CALEO} TD 200 - 300 XTRA fan option

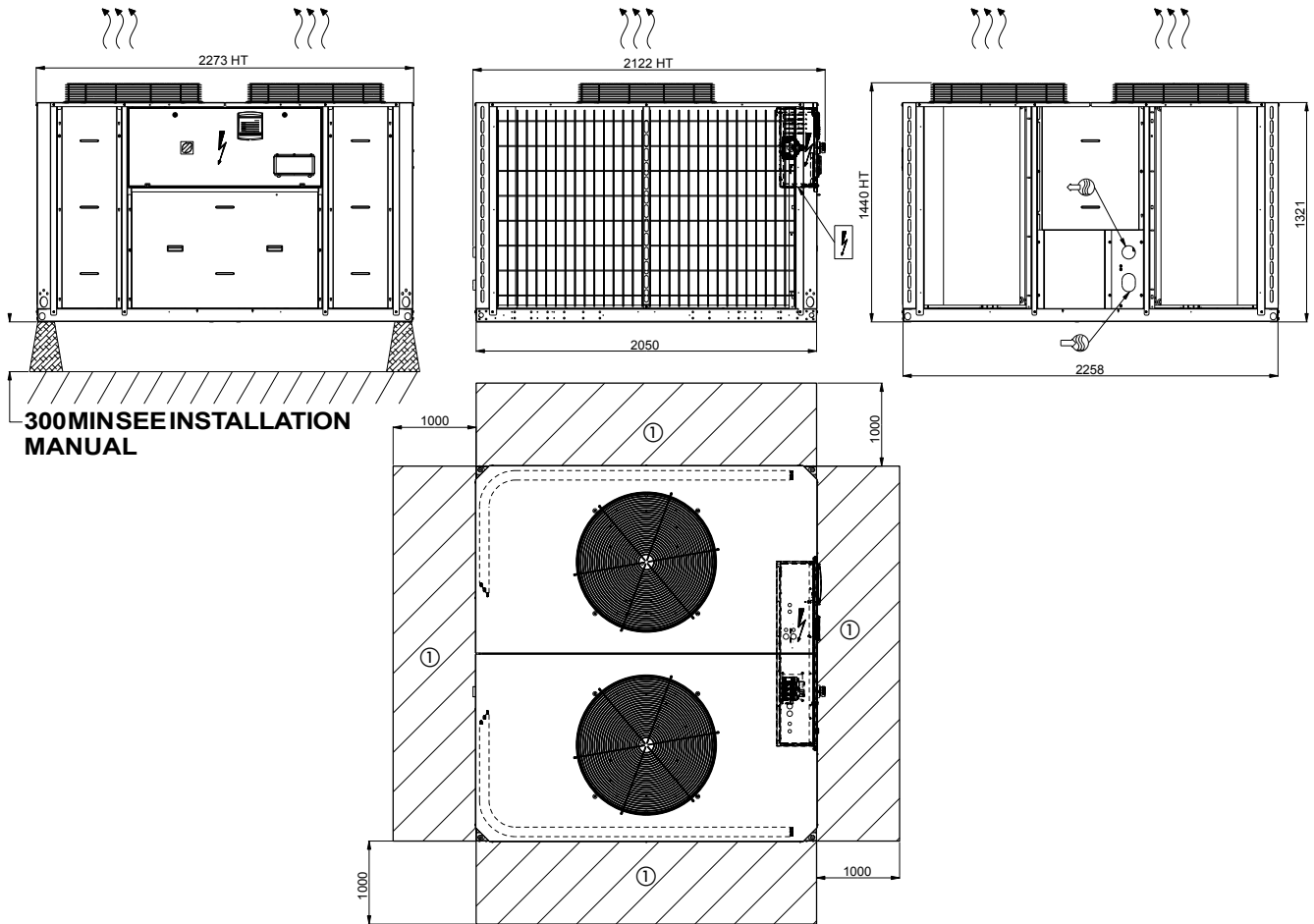

Key

Dimensions en mm

- ① Clearance required for maintenance and air flow
- ↗ Water inlet
- ↖ Water outlet
-))) Air outlet, do not obstruct
- ⚡ Electrical cabinet

NOTES :

Non-contractual drawings.

When designing a system, refer to the certified dimensional drawings provided with the unit or available on request.

Please refer to the certified dimensional drawings for the positioning of the fixing points, weight distribution points and centre of gravity coordinates.

INSTALLATION RECOMMENDATIONS

■ Water quality criteria to be respected

Warning: *It is essential that an 800-micron water filter be placed on the unit's water inlet during installation. The quality of the water used has a direct impact on the correct and compliant operation of the machine and its service life. This is particularly true if the water used clogs or corrodes components or promotes the growth of algae or micro-organisms. The water must be tested to determine whether it is suitable for the unit. It is also tested to determine whether chemical treatment is necessary and will suffice to make it of acceptable quality. This analysis should confirm whether or not the various machine components are compatible with the water they come into contact with on-site.*

Warning: *failure to follow these instructions will result in the immediate voiding of the unit's warranty.*

■ Lifting and handling

The utmost safety precautions must be taken when lifting and handling the unit.

Always follow the lifting diagram on the unit and in the instruction manual.

Before attempting to lift the unit, make sure the path leading to its intended location is free from obstacles. Always keep the unit vertical when moving it. Never tip it or lie it on its side.

■ Choosing a location for the unit

AQUACIAT^{CALEO} units are designed for outdoor installation. Precautions should be taken to protect them from freezing temperatures. Special attention should be paid to ensure sufficient free space (including at the top) to allow maintenance. The unit must be placed on a perfectly level, fireproof surface strong enough to support it when ready for operation. Noise pollution from auxiliary equipment such as pumps should be studied thoroughly.

Potential noise transmission routes should be studied, with assistance from an acoustical engineer if necessary, before installing the unit. It is strongly recommended that flexible couplings are placed over pipes and anti-vibration mounts are fitted underneath the unit (equipment available as an option) to reduce vibrations, and the noise this causes, as much as possible.

■ Fitting accessories supplied separately

A number of optional accessories may be delivered separately and installed on the unit on site.

You must follow the instructions in the manual.

■ Electrical connections

You must follow the instructions in the manual. All information concerning electrical connections is stated on the wiring diagrams provided with the unit. Always follow this information to the letter.

Electrical connections must be made in accordance with best current practices and applicable standards and regulations. Electrical cable connections to be made on-site:

- Electrical power supply to unit
- Contacts available as standard enabling the machine to be controlled remotely (optional)

It should be noted that the unit's electrical system is not protected against lightning strikes.

Therefore devices to protect against transient voltage surges must be installed on the system and inside the power supply unit.

■ Pipe connections

You must follow the instructions in the manual. All pipes must be correctly aligned and slope toward the system's drain valve. Pipes must be installed to allow sufficient access to the panels and fitted with heat insulation.

Pipe mountings and clamps must be separate to avoid vibrations and pressure on the unit. Water flow shut-off and control valves must be fitted when the unit is installed.

Pipe connections to be made on-site:

- Water supply with pressure-reducing valve
- Evaporator, condenser and drain

The following are a few examples of accessories essential to any hydraulic circuit, which must also be installed:

- Water expansion vessel
- Drain nozzles at pipe low points
- Exchanger shut-off valves equipped with filters
- Air vents at pipe high points
- Check the system's water capacity (install a buffer water tank if necessary)
- Flexible couplings on exchanger inlets and outlets

Warning:

- **Pressure in the water circuits below 4 bar for units equipped with the hydraulic module.**
- **Place the expansion vessel upstream of the pump.**
- **Do not place any valves on the expansion vessel.**
- **Make sure the water circulation pumps are placed directly at the exchanger inlets.**
- **Make sure the pressure of the water drawn in by the circulation pumps is greater than or equal to the required minimum NPSH, particularly if the water circuits are "open".**
- **Test the water quality in accordance with the relevant technical specifications.**
- **Take the necessary precautions to protect the unit and hydraulic system from freezing temperatures (e.g. allow for the possibility of draining the unit). If glycol is added to prevent freezing, check its type and concentration before system start-up.**
- **Before making any final hydraulic connections, flush the pipes with clean water to remove any debris in the network**

INSTALLATION RECOMMENDATIONS

■ System start-up

CIAT or a CIAT-approved firm must perform system start-up on the units.

You must follow the instructions in the manual.

List of system start-up checks (non-exhaustive):

- Correct siting of unit
- Power supply protections
- Phases and direction of rotation
- Wiring connections on unit
- Direction of water flow in unit
- Cleanliness of water circuit
- Water flow rate at specified value
- Pressure in the refrigerating circuit
- Direction of rotation of compressors
- Water pressure drops and flow rates
- Operating readings

■ Maintenance operations

Specific preventive maintenance operations are required at regular intervals and should be performed by CIAT-approved contractors.

The operating parameters are read and noted on a "CHECK LIST" form to be returned to CIAT.

It is essential to comply with the instruction manual.

You must take out a maintenance contract with a CIAT-approved refrigeration equipment specialist. Such a contract is required even during the warranty period.

CONTROL

USER-FRIENDLY INTERFACE CONSOLE

- User-friendly 4.3-inch touch screen.
- Information displayed in a choice of languages.
- Temperature and pressure readings.
- Operating and fault status diagnostics.
- Master/slave control of two machines in parallel.
- Fault memory management.
- Pump management.
- Time schedule.
- IP Web server.
- Programmable maintenance.
- Preventive maintenance.
- FGAS maintenance.
- E-mail alerts.



REMOTE M2M MACHINE SUPERVISION

Two years of Full Serenity with:

- Monitoring of machine operation (operation overviews and curves, alarm logs).
- E-mail alerts for alarms (optional SMS alerts).
- Remote update of the M2M.
- Access to a log of machine operation data.
- Remote advice for using M2M.
- System start-up and operating readings.

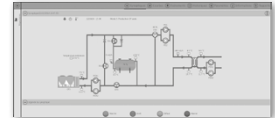

PRODUCT FUNCTIONALITY



Via potential-free (dry) contact

POTENTIAL-FREE (DRY) CONTACTS AVAILABLE AS STANDARD

Inputs:

- Automatic operation control
- Selection of setpoints 1 / 2
- Domestic hot water demand

Outputs:

- General fault reporting
- On/off control for a boiler
- 4-stage on/off management for additional heaters.

Additional inputs available as options:

- Setpoint adjustable by 4-20 mA signal

Customer CMS COMMUNICATION

Via BUS communication

AVAILABLE OUTPUTS

- MODBUS-JBUS RTU (RS485) or TC/IP (standard) open protocol
- LONWORKS protocol (option)
- BACNET IP protocol (option) certified BTL

CIAT SYSTEM FUNCTIONALITY

Communication with Hysys system (generator, transmitter, air handling unit), controlled by an Easy CIATcontrol or Smart CIATcontrol touch tablet.

- **Logging** of consumption data and temperatures
- **OptimalWater®**: optimisation of producer performance based on building requirements
- **Optimal Stop and Start**: optimisation of the building restart time





Order No.: NA21.761A. Supersedes order No.: NA19.761A.

Manufacturer reserves the right to change any product specifications without notice.

The illustrations in this document are for illustrative purposes only and not part of any offer for sale or contract. The manufacturer reserves the right to change the design at any time without notice.

Manufactured by: Carrier SCS, Montluel, France.